



Chimei-Innolux Corporation

BT140GW01 V.9 LCD MODULE SPECIFICATION

- () Preliminary Specification
 (●) Final Specification

Customer	Checked & Approved by

Approved by	Checked by	Prepared by
MKT	PD	PM

Date: 2010/11/08

Chimei-Innolux Corporation

No.160 Kesyue Rd., Chu-Nan Site, Hsinchu Science Park,

Chu-Nan 350, Miao-Li County, Taiwan

Tel: 886-37-586000

Fax: 886-37-586060

Version: 11

Chimei-Innolux copyright
All rights reserved,
Copying forbidden.

Record of Revision

Version	Revise Date	Page	Content
0	2010/04/07	All	First Edition issued
1	2010/04/08	5	Pin Assignment
		11	Power Sequence Timing Table
		14	Backlight Driving Condition
2	2010/04/13	16	Optical Specification
3	2010/04/15	8	Typical Operating Condition
4	2010/04/22	27~30	EDID
5	2010/04/26	21	Label
6	2010/05/19	16	Optical specifications
7	2010/07/16	16	Optical specifications
8	2010/08/11	4	General Specifications
		14	Backlight driving conditions
9	2010/08/25	1	Cover Page – Add 18G241400222* (Foxconn)
		22	Label drawing
		27	Label position
10	2010/10/03	24	Package drawing change
11	2010/11/08	22	Label Definition (Revise model name position & Revise Carton P/N)

Contents:	Page
1. General Specifications	4
2. Electrical Specifications	
2-1 Pin Assignment	5
2-2 Absolute Maximum Ratings	7
2-3 Electrical Characteristics	8
3. Optical Specifications	17
4. Reliability Test Items	20
5. Safety	21
6. Display Quality	21
7. Handling Precaution	21
8. Label Definition	22
9. Packing Form	24
10. Mechanical Drawings	25
Appendix	27

1. General Specifications

NO.	Item	Specification	Unit
1	Display resolution (pixel)	1366(H) X 768(V), HD resolution	
2	Active area	309.40(H) X 173.95(V)	mm
3	Screen size	14.0 inches diagonal	Inches
4	Pixel pitch	0.2265(H) X 0.2265(V)	mm
5	Color configuration	Stripe	
6	Overall dimension	324(W) X 192.5(H) X 5.2(D) (max)	mm
7	Weight	350Max.	Grams
8	Surface treatment	Glare, 3H	
9	Input color signal	6 bit LVDS	
10	Display colors	262K (6 bit)	
11	Optimum viewing direction	6 o'clock	
12	Backlight	W-LED	
13	Glass thickness	0.5	mm
14	LED life time with LCM	12,000 (min.), T = 25°C	Hours
15	Backlight unit	LEDs 9 X 4	
16	Power Consumption	4.2 max @ Black Pattern	Watt
17	RoHS Compliance	Yes	

Electrical Specifications

2-1 Pin Assignment

a. Panel connector

Connector Part No: GS13401-1110S-7H (Foxconn) & 20455-040E-12 (I-PEX)

User's connector Part No: 20453-040T-12(I-PEX) or equivalent

Pin No	Symbol	Description	Remark
1	NC	No connection (Reserve)	
2	V _{CC}	Power Supply (+3.3V)	
3	V _{CC}	Power Supply (+3.3V)	
4	V _{EDID}	DDC Power +3.3V	
5	NC	No connection (Reserve)	
6	Clk _{EDID}	DDC Clock	
7	DATA _{EDID}	DDC Data	
8	Rxin0-	Differential Data Input	R0~R5,G0
9	Rxin0+	Differential Data Input	
10	GND	Ground	
11	Rxin1-	Differential Data Input	G1~G5,B0,B1
12	Rxin1+	Differential Data Input	
13	GND	Ground	
14	Rxin2-	Differential Data Input	B2~B5,DE,Hsync,Vsync
15	Rxin2+	Differential Data Input	
16	GND	Ground	
17	CLK-	Differential Clock Input	
18	CLK+	Differential Clock Input	
19	GND	Ground	
20	NC	No connection (Reserve)	
21	NC	No connection (Reserve)	
22	GND	Ground	
23	NC	No connection (Reserve)	
24	NC	No connection (Reserve)	
25	GND	Ground	
26	NC	No connection (Reserve)	
27	NC	No connection (Reserve)	
28	GND	Ground	
29	NC	No connection (Reserve)	
30	NC	No connection (Reserve)	
31	LED_GND	LED Ground	
32	LED_GND	LED Ground	
33	LED_GND	LED Ground	
34	NC	No connection (Reserve)	
35	LED_PWM	PWM dimming signal input	
36	LED_EN	LED enable pin (3.3V)	
37	NC	No connection (Reserve)	
38	V_LED	LED power supply 6V~21V	
39	V_LED	LED power supply 6V~21V	
40	V_LED	LED power supply 6V~21V	

b. General block diagram (Rear-side)

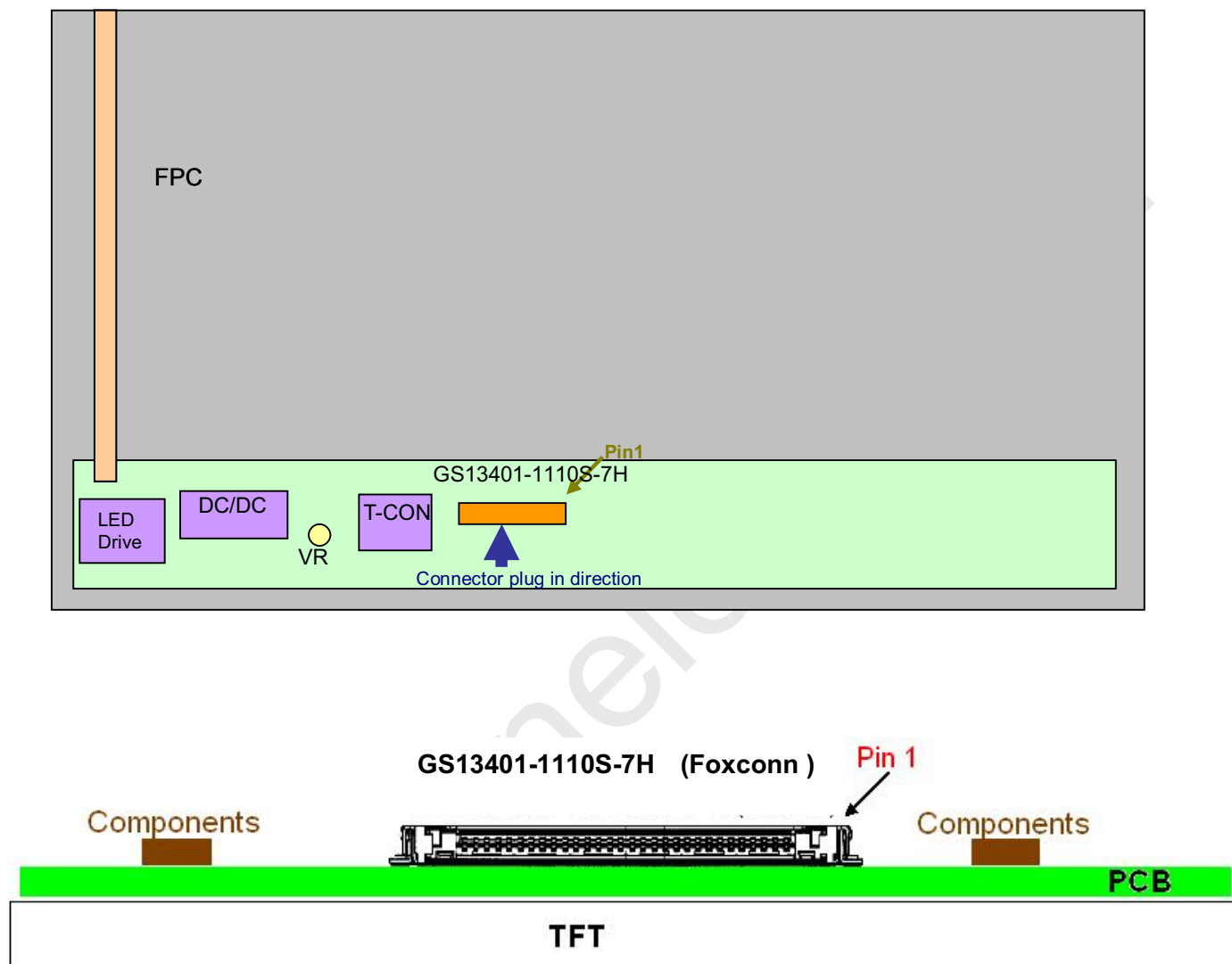

2-2. Absolute Maximum Ratings

Parameter	Symbol	Values		Unit	Remark
		Min.	Max.		
Power input voltage	V_{CC}	- 0.3	4.0	V	At 25°C
Signal input voltage	V_{IN}	- 0.3	4.0	V	At 25°C
LED input voltage	V_{LED}	- 0.3	30	V	At 25°C
Operating temperature	T_{OP}	0	50	°C	Note 1
Storage temperature	T_{ST}	- 20	60	°C	Note 2
Re-screw		-	5	Times	
Assured torque at side mount		-	2	kgf.cm	

Note 1: The relative humidity must not exceed 90%, non-condensing at temperatures of 40°C or less. At temperatures greater than 40°C, the wet bulb temperature must not exceed 39°C.

Note 2: The unit should not be exposed to corrosive chemicals.

Relative Humidity (%RH)

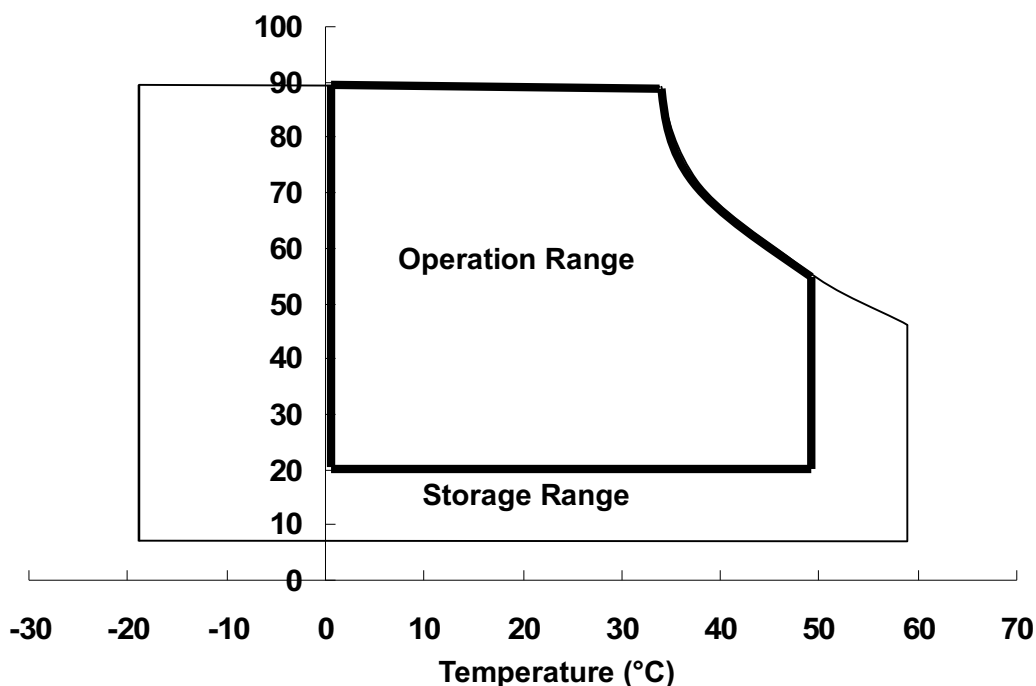

2-3. Electrical Characteristics

a. Typical operating conditions

Item	Symbol	Min.	Typ.	Max.	Unit	Remark	
Power input voltage	V_{CC}	3	3.3	3.6	V		
Permissive power input ripple	V_{RF}	-	-	0.1	V		
Power input current	I_{CC}	-	300	330	mA	Note 1	
Power consumption	P_C	-		1.0	Watts	Note 1	
LVDS interface	Differential input high threshold voltage	V_{LVTH}	-	-	+100	mV	LVDS interface
	Differential input low threshold voltage	V_{LVTL}	-100	-	-	mV	
	Common input voltage	V_{LVC}	1.0	1.2	1.4	V	
	Terminating resistor	R_T	90	100	110	ohm	
Rush current	I_{Rush}	-	-	1.5	A	Note 3	
LED rush current	$I_{LED-Rush}$	-	-	3.0	A	Note 4	

Note 1: The specified input current and power consumption are under the $V_{CC} = 3.3\text{ V}$, 25°C , $f_V = 60\text{ Hz}$ (frame frequency) condition whereas mosaic pattern is displayed.

Note 2: LVDS waveform diagram

Rxin+/CLK+

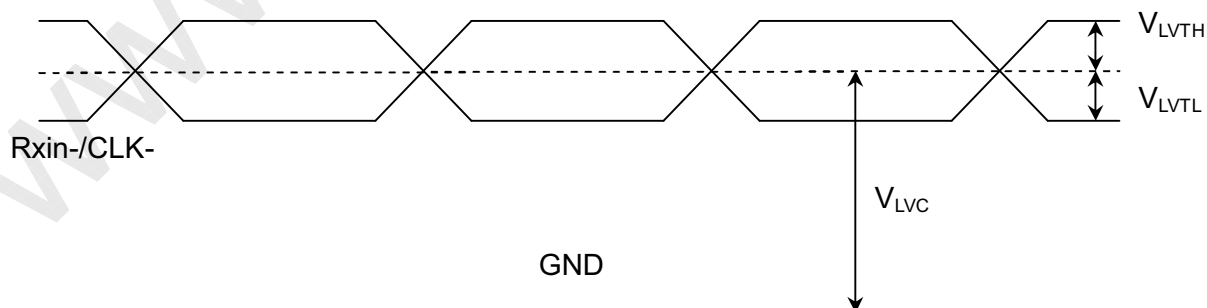

Note 3: Test condition

(1) Pattern: Black pattern

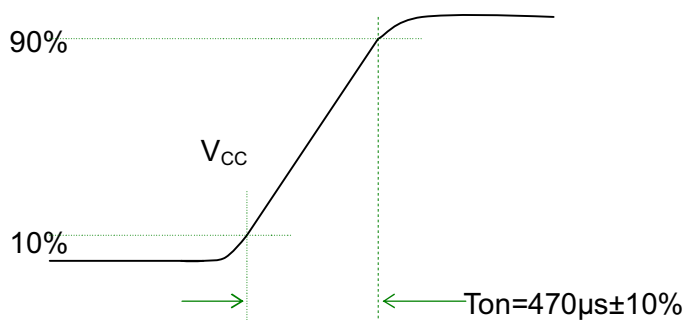
(2) $V_{CC} = 3.3\text{ V}$, V_{CC} rising time = $470\ \mu\text{s} \pm 10\%$ 

(3) Test circuit

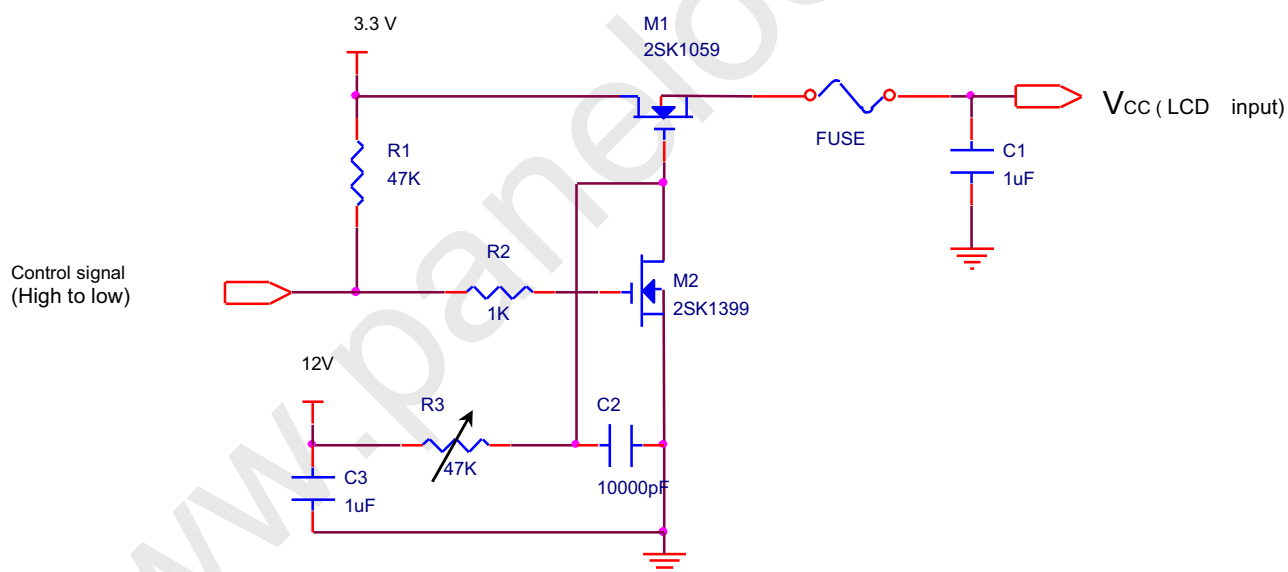

Note 4: Test condition

(1) Pattern: LED duty 100%

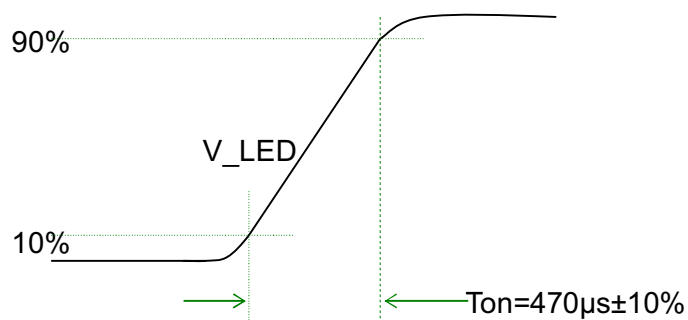
(2) $V_{LED} = 12.0V$, V_{LED} rising time = $470 \mu s \pm 10\%$ 

(3) Test circuit

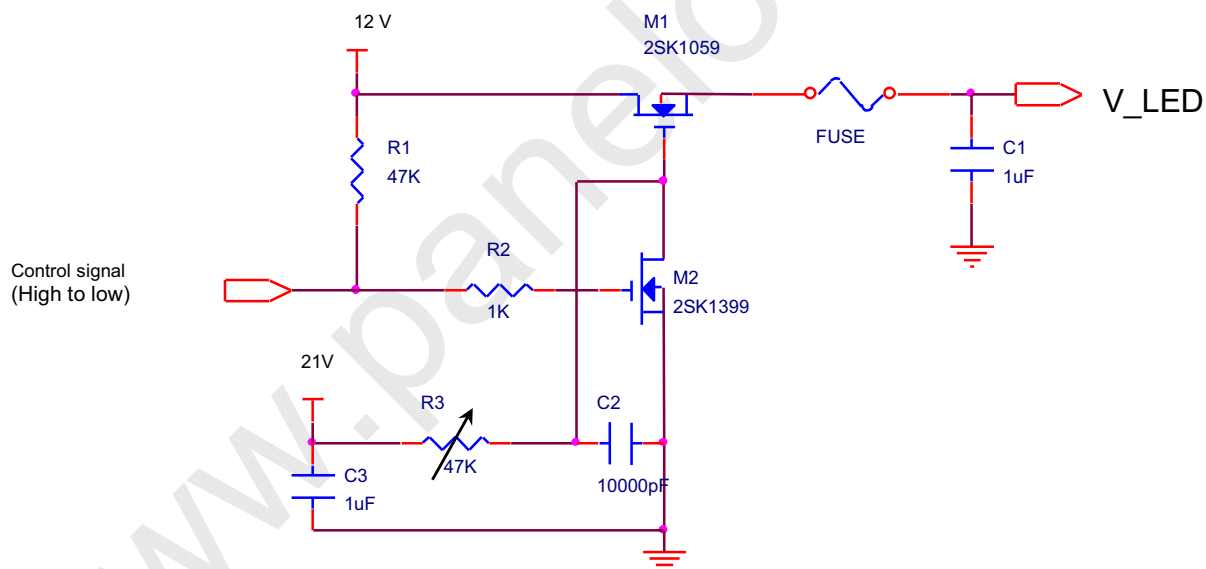

b. Power sequence

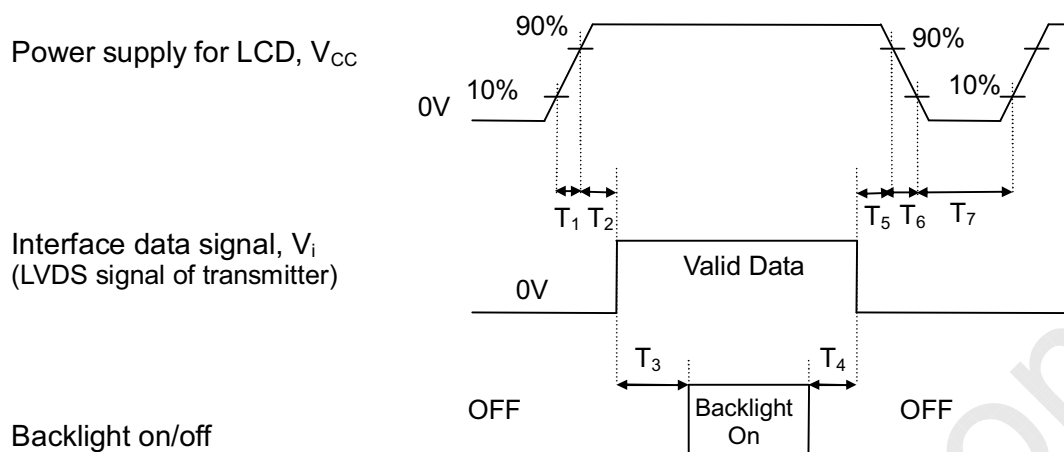

Power sequence timing table

Parameter	Value			Units
	Min.	Typ.	Max.	
T_1	0.5	-	10	ms
T_2	0	-	50	ms
T_3	200	-	-	ms
T_4	200	-	-	ms
T_5	0	-	50	ms
T_6	0.5	-	10	ms
T_7	400	-	-	ms

c. Display color vs. input data signals

Signal Name	Description	Remark
R5	Red Data 5 (MSB)	Red-pixel data. Each red pixel's brightness data consists of these 6 bits pixel data.
R4	Red Data 4	
R3	Red Data 3	
R2	Red Data 2	
R1	Red Data 1	
R0	Red Data 0 (LSB)	
	Red-pixel Data	
G5	Green Data 5 (MSB)	Green-pixel data. Each green pixel's brightness data consists of these 6 bits pixel data.
G4	Green Data 4	
G3	Green Data 3	
G2	Green Data 2	
G1	Green Data 1	
G0	Green Data 0 (LSB)	
	Green-pixel Data	
B5	Blue Data 5 (MSB)	Blue-pixel data. Each blue pixel's brightness data consists of these 6 bits pixel data.
B4	Blue Data 4	
B3	Blue Data 3	
B2	Blue Data 2	
B1	Blue Data 1	
B0	Blue Data 0 (LSB)	
	Blue-pixel Data	

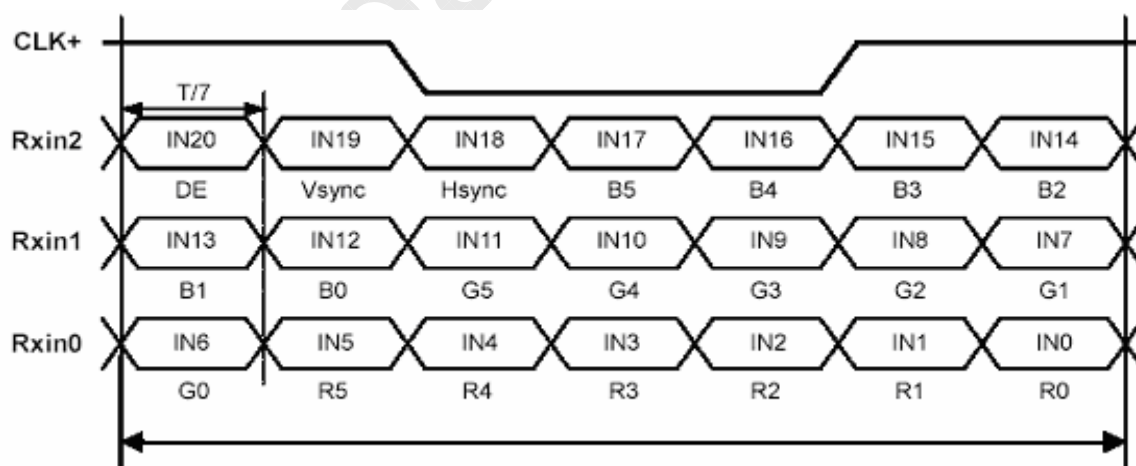
Signal for 1 DCLK cycle (t_{CLK})

d. Input signal timing

Timing table

Description	Symbol	Min	Typ	Max	Unit
Frame rate	--	40	60	--	Hz
Clock freq.	$1/t_{CLK}$	45	71	85	MHz
Line cycle time	t_H	1400	1498	1800	t_{CLK}
Line width-active	t_{Hd}	1366	1366	1366	t_{CLK}
Frame cycle time	t_V	780	790	900	t_H
V width-active	t_{Vd}	768	768	768	t_H

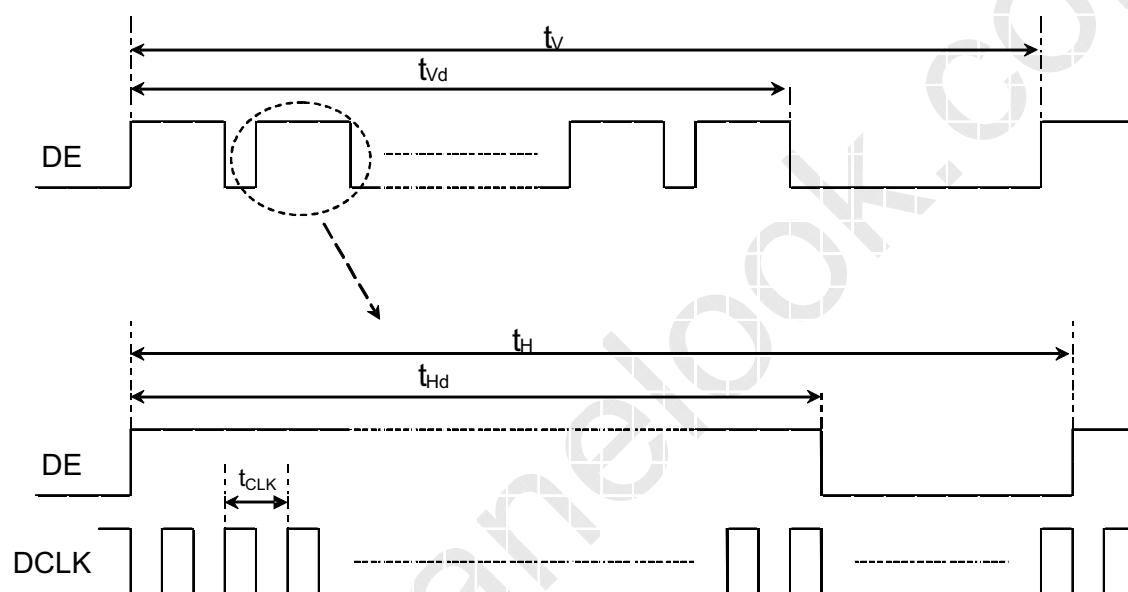

e. Display position

D(1, 1)	D(2, 1)	D(683, 1)	D(1365, 1)	D(1366, 1)
D(1, 2)	D(2, 2)	D(683, 2)	D(1365, 2)	D(1366, 2)
⋮		⋮	⋮	⋮
D(1, 384)	D(2, 384)	D(683, 384)	D(1365, 384)	D(1366, 384)
⋮		⋮	⋮	⋮
D(1, 767)	D(2, 767)	D(683, 767)	D(1365, 767)	D(1366, 767)
D(1, 768)	D(2, 768)	D(683, 768)	D(1365, 768)	D(1366, 768)

f. Backlight driving conditions

Parameter		Symbol	Min.	Typ.	Max.	Unit	Remark
Converter Input power supply voltage		LED_Vccs	6	12	21	V	
LED forward voltage		V _F	3	3.2	3.4	V	T = 25°C
EN Control Level	Backlight On		2.4	-	3.6	V	
	Backlight Off		0	-	0.8	V	
LED forward current		I _F		20		mA	T = 25°C
LED power consumption		P _{LED}		2.8	3	W	T = 25°C, Note 1
		P _{LED-G}			1.2	W	Note 2
Input PWM frequency		F _{PWM}	190	1000	2000	Hz	T = 25°C
Converter Input Current	LED_VCCS=Min	I _{BL}	365	430	505	mA	T = 25°C
	LED_VCCS=Typ		178	210	247		T = 25°C
	LED_VCCS=Max		98	115	135		T = 25°C
Duty ratio		-	5		100	%	Note 3
LED life time (LED only)		-	15,000			Hr	T = 25°C, Note 4

Note 1: Converter efficiency 85%(typ)

Note 2: The BL power consumption @100 nits with full white pattern under the V_{cc} =3.3 V, 25 °C, f_v=60Hz (frame frequency) condition

Note 3: PWM duty ratio linearity guarantees 10~100%.

Note 4: LED life time definition is brightness decrease to 50% of initial or abnormal lighting.

g. Module function block

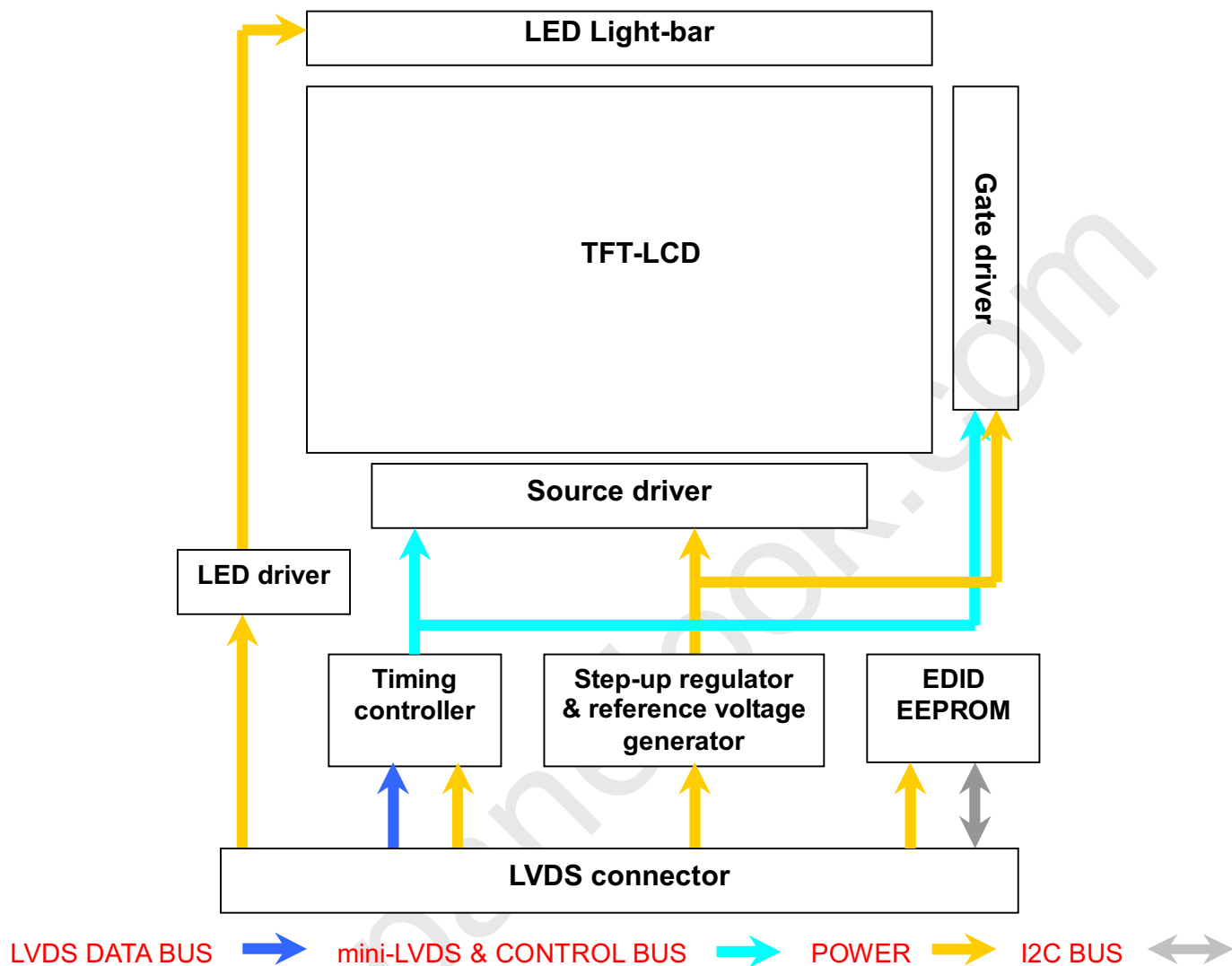

h. LED circuit block

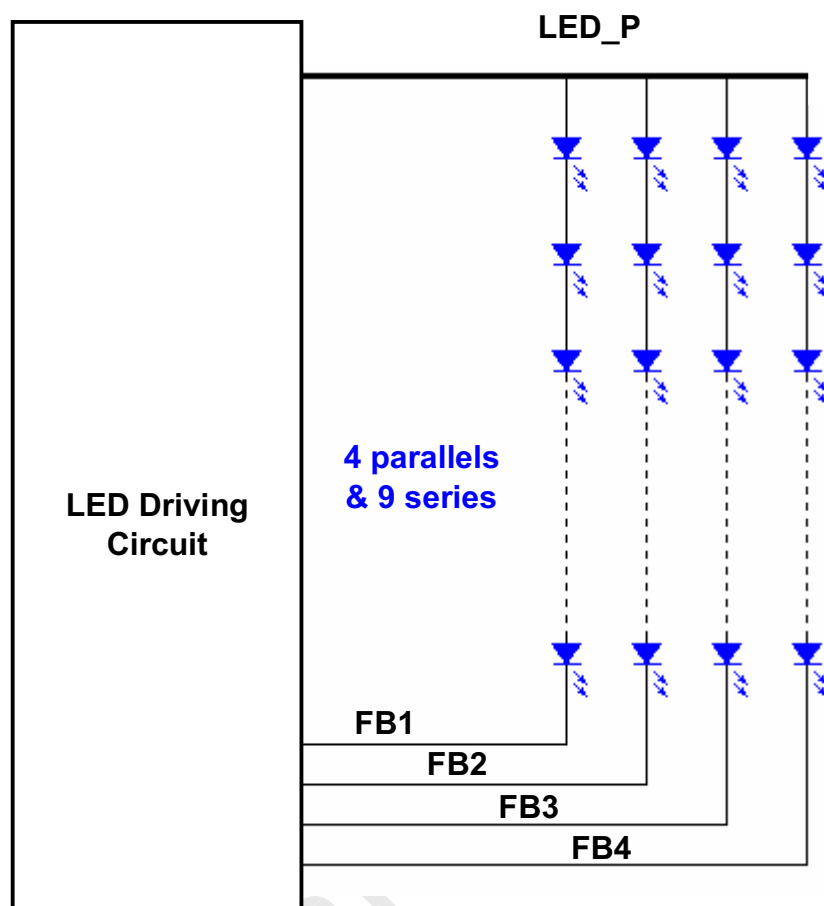

3. Optical specifications

Ambient temperature = 25°C

Item	Symbol	Condition	Specification			Unit	Remark
			Min.	Typ.	Max.		
Response time	Tr+Tf	$\theta = 0^\circ$		8	15	ms	Note 3
Contrast ratio	CR	$\theta = 0^\circ$	500	600			Note 2,4
Viewing angle	Top	$CR \geq 10$	15			deg	Note 2,4,6
	Bottom		30				
	Left		40				
	Right		40				
	Top	$CR \geq 100$	6				
	Bottom		11				
	Left		25				
	Right		25				
Brightness (5 points average)	Y_L		190	220		nit	Note 2,5
Color chromaticity (CIE)	W_x	$\theta = 0^\circ$	-0.03	0.313	+0.03		Note 2
	W_y			0.329			
	R_x			0.586			
	R_y			0.355			
	G_x			0.323			
	G_y			0.57			
	B_x			0.163			
	B_y			0.141			
Color gamut	NTSC	CIE1931		45		%	-
White uniformity	$\delta_{W(5)}$				1.25		Note 2,7
	$\delta_{W(13)}$				1.5		
Cross talk	Ct				2%		Note 8

Note 1: To be measured in dark room.

Note 2: To be measured with a viewing cone of 2° by Topcon luminance meter BM-5A.

Note 3: Definition of response time:

The output signals of BM-7 are measured when the input pattern are changed from "Black" to "White" (falling time) and from "White" to "Black" (rising time), respectively. The response time interval is between 10% and 90% of amplitudes. Refer to figure as below.

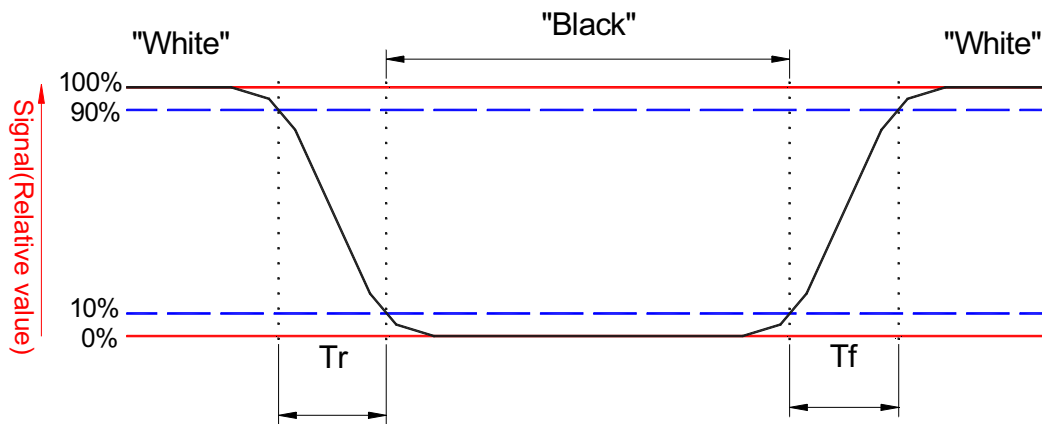

Note 4: Definition of contrast ratio:

Contrast ratio is calculated with the following formula:

$$\text{Contrast ratio (Avg of 5pts)} = \frac{L_{\text{white (Avg of 5pts.)}}}{L_{\text{Black (Avg of 5pts.)}}}$$

Note 5: Driving current for LED should be 20 mA.

Luminance is measured at the following thirteen points (1~13):

$$Y_L = (Y_5 + Y_{10} + Y_{11} + Y_{12} + Y_{13}) / 5$$

Note 6: Definition of viewing angle

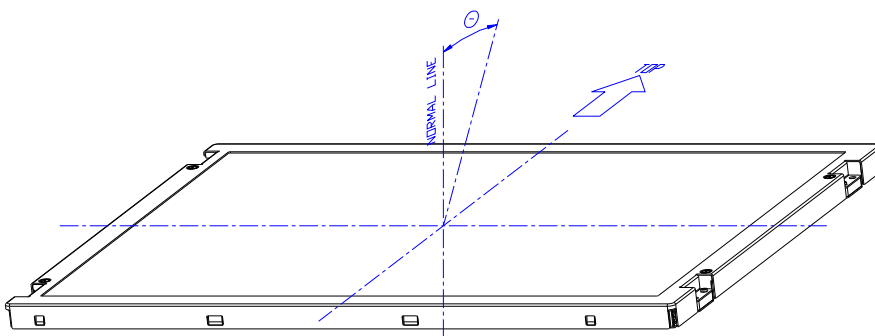

Note 7: Definition white uniformity

Luminance is measured at the following thirteen points (1~13):

$$\delta_{W(13)} = \frac{\text{Maximum brightness of thirteen points}}{\text{Minimum brightness of thirteen points}}$$

$$\delta_{W(5)} = \frac{\text{Maximum brightness of five points}}{\text{Minimum brightness of five points}}$$

13 point measuring locations refer to the point 1, 2, 3, 4, 5, 6, 7, 8, 9, 10, 11, 12 and 13.

5 point measuring locations refer to the point 5, 10, 11, 12 and 13.

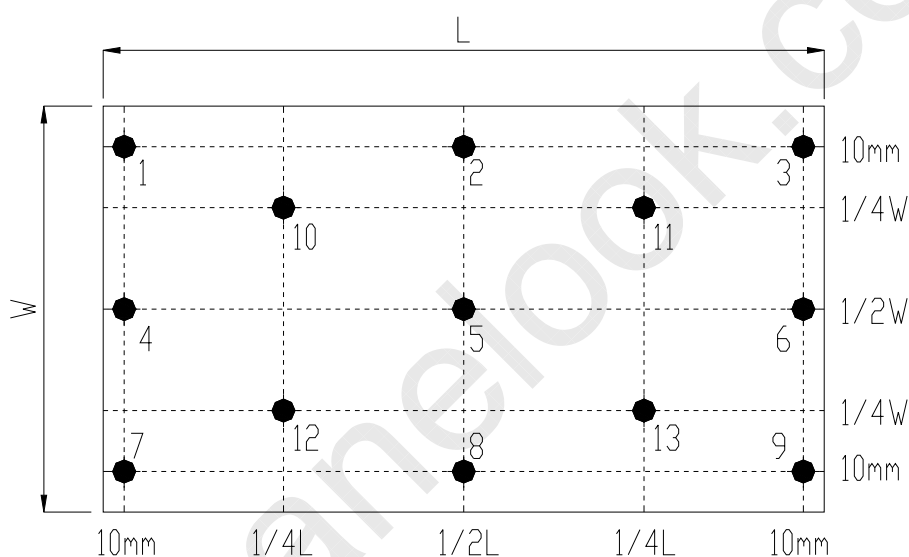

Note 8:

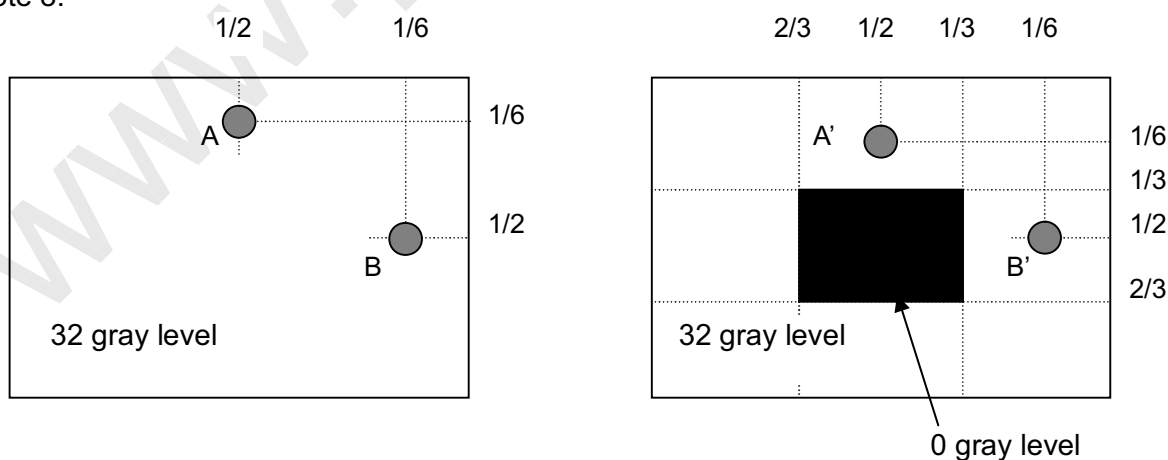

Unit: percentage of dimension of display area

$|L_A - L_{A'}| / L_A \times 100\% = 2\% \text{ max.}$, L_A and $L_{A'}$ are brightness at location A and A'

$|L_B - L_{B'}| / L_B \times 100\% = 2\% \text{ max.}$, L_B and $L_{B'}$ are brightness at location B and B'

4. Reliability test items

Test Item	Test Condition	Judgment	Remark
High temperature storage	60°C, 240 hours	Note 1	Note 2
Low temperature storage	-20°C, 240 hours	Note 1	Note 2
High temperature & high humidity operation	50°C, 80% RH, 240 hours (No condensation)	Note 1	Note 2
High temperature operation	50°C, 240 hours	Note 1	Note 2
Low temperature operation	0°C, 240 hours	Note 1	Note 2
Thermal shock (Non-operation)	-20°C / 30 mins ~ 60°C / 30 mins 100 cycles	Note 1	Note 2
Electrostatic discharge (ESD)	150 pF, 330Ω, Contact: ±8kV, Air: ±15kV	Note 1	
Vibration (Non-operation)	1.5G, 10 to 500 Hz random; 0.5hr in each perpendicular axes (X, Y, Z).	Note 1	Note 2
Mechanical shock (Non-operation)	220G/2ms, Half sine wave, ±X, ±Y, ±Z one time for each direction	Note 1	Note 2

Note 1: Pass: Normal display image with no obvious non-uniformity and no line defect.

Fail: No display image, obvious non-uniformity, or line defects.

Partial transformation of the module parts should be ignored.

Note 2: Evaluation should be tested after storage at room temperature more than one hour.

5. Safety

5-1. Sharp edge requirements

There will be no sharp edges or corners on the display assembly that could cause injury.

5-2. Materials

a. Toxicity

There will be no carcinogenic materials used anywhere in the display module. If toxic materials are used, they will be reviewed and approved by the responsible InnoLux Toxicologist.

b. Flammability

All components including electrical components that do not meet the flammability grade UL94-V0 in the module will complete the flammability rating exception approval process. The printed circuit board will be made from material rated 94-V0 or better. The actual UL flammability rating will be printed on the printed circuit board.

c. Capacitors

If any polarized capacitors are used in the display assembly, provisions will be made to keep them from being inserted backwards.

6. Display quality

The display quality of the color TFT-LCD module should be in compliance with the InnoLux incoming inspection standard.

7. Handling precaution

- (1) Do not apply rough force such as bending or twisting to the module during assembly.
- (2) To assemble or install module into user's system can be only in clean working areas. The dust and oil may cause electrical short or worsen the polarizer.
- (3) It's not permitted to have pressure or impulse on the module because the LCD panel and backlight will be damaged.
- (4) Always follow the correct power sequence when LCD module is connecting and operating.
- (5) Do not pull the I/F connector in or out while the module is operating.
- (6) Do not disassemble the module.
- (7) Use a soft dry cloth without chemicals for cleaning, because the surface of polarizer is very soft and easily scratched.
- (8) It is dangerous that moisture come into or contacted the LCD module, because moisture may damage LCD module when it is operating.
- (9) High temperature or humidity may reduce the performance of module. Please store LCD module within the specified storage conditions.

8. Label Definition

8-1. Module label

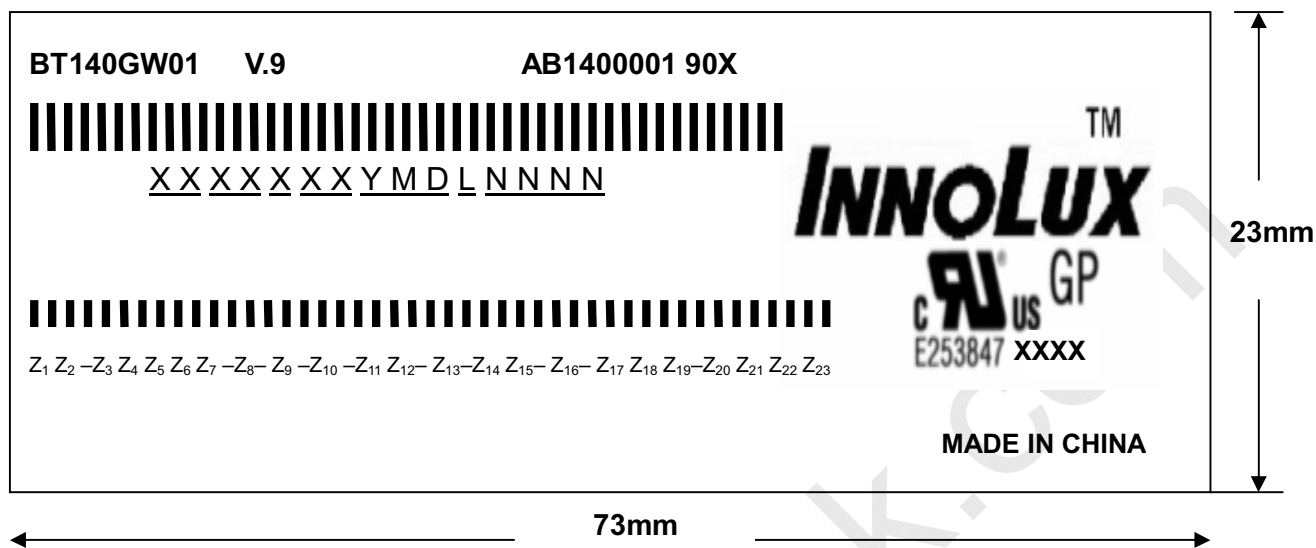

- (a) Model Number : BT140GW01 V.9
- (b) Product Number : AB140000190X
- (c) Serial ID: XXXXXXXXYMDLNNNN

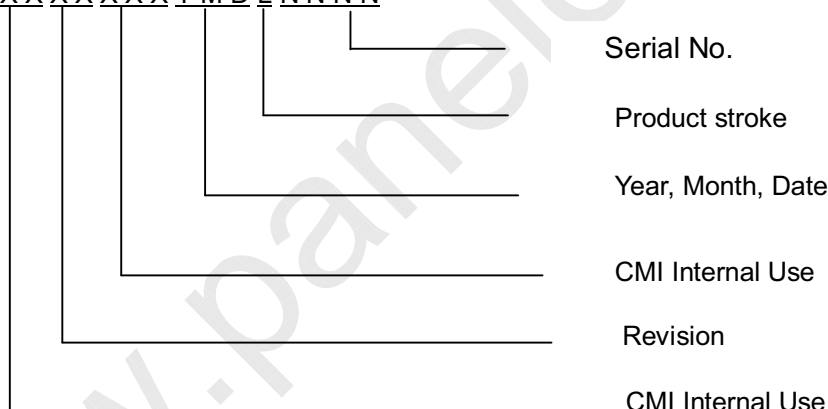

- (d) Production Location: MADE IN XXXX.
- (e) UL/CB logo: "XXXX" especially stands for panel manufactured by CMI Ningbo satisfying UL/CB requirement. "LEOO" "CANO" is the CMI's UL factory code for Ningbo factory.

Serial ID II (INL Internal Use):

Z₁ Z₂ -Z₃ Z₄ Z₅ Z₆ Z₇ -Z₈ -Z₉ -Z₁₀ -Z₁₁ Z₁₂ -Z₁₃ -Z₁₄ Z₁₅ -Z₁₆ -Z₁₇ Z₁₈ Z₁₉ -Z₂₀ Z₂₁ Z₂₂ Z₂₃

8-2. Carton label

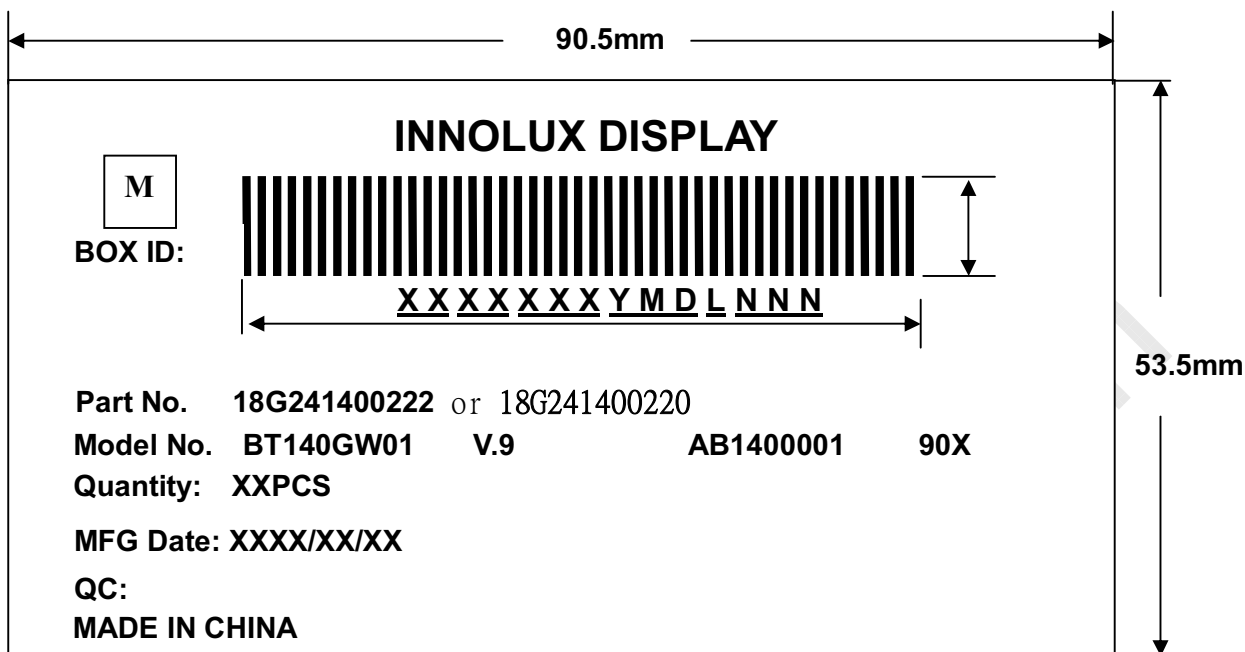

(a) Model No. : BT140GW01 V.9

(b) Package Quantity: XXPCS

(c) Serial ID: XXXXXXYMDLNNN

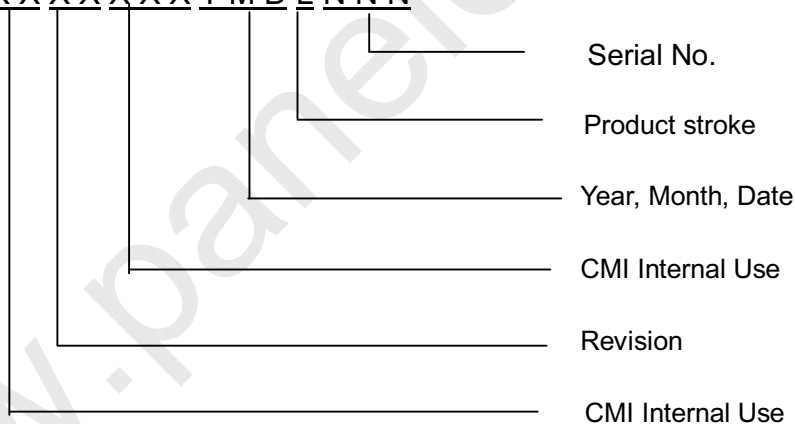

SPEC NO. BT140GW01 V.9

PAGE 24/30

9. Packing Form



↓ Step A
Put LCM into A/S bag



↓ Step B
Turn back A/S bag

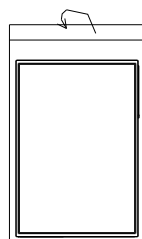

↓ Step C



Step D
Put LCM with A/S bag into

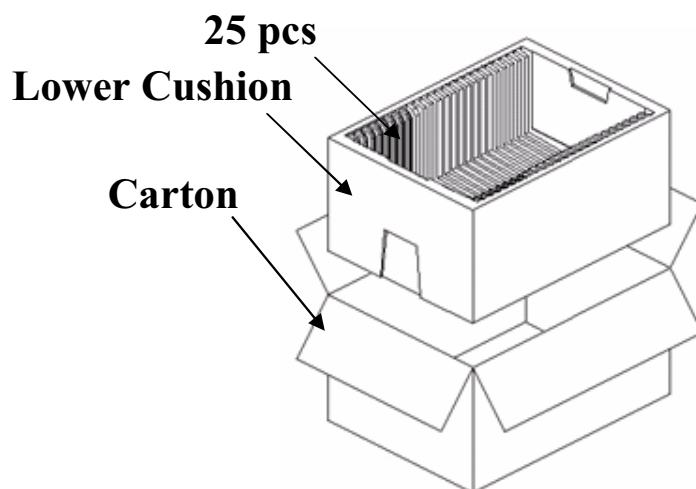

Step E

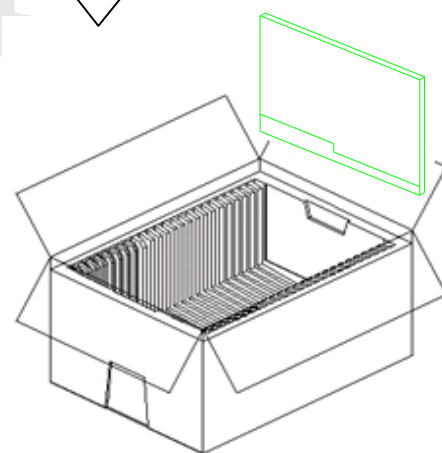

Step F

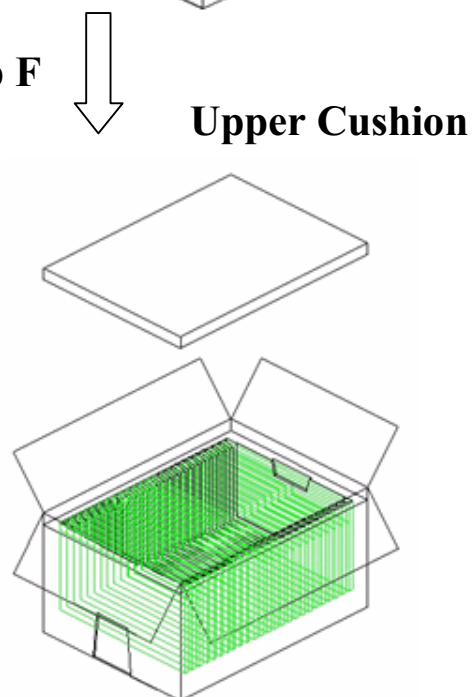



10. Mechanical Drawings 10-1. Front side

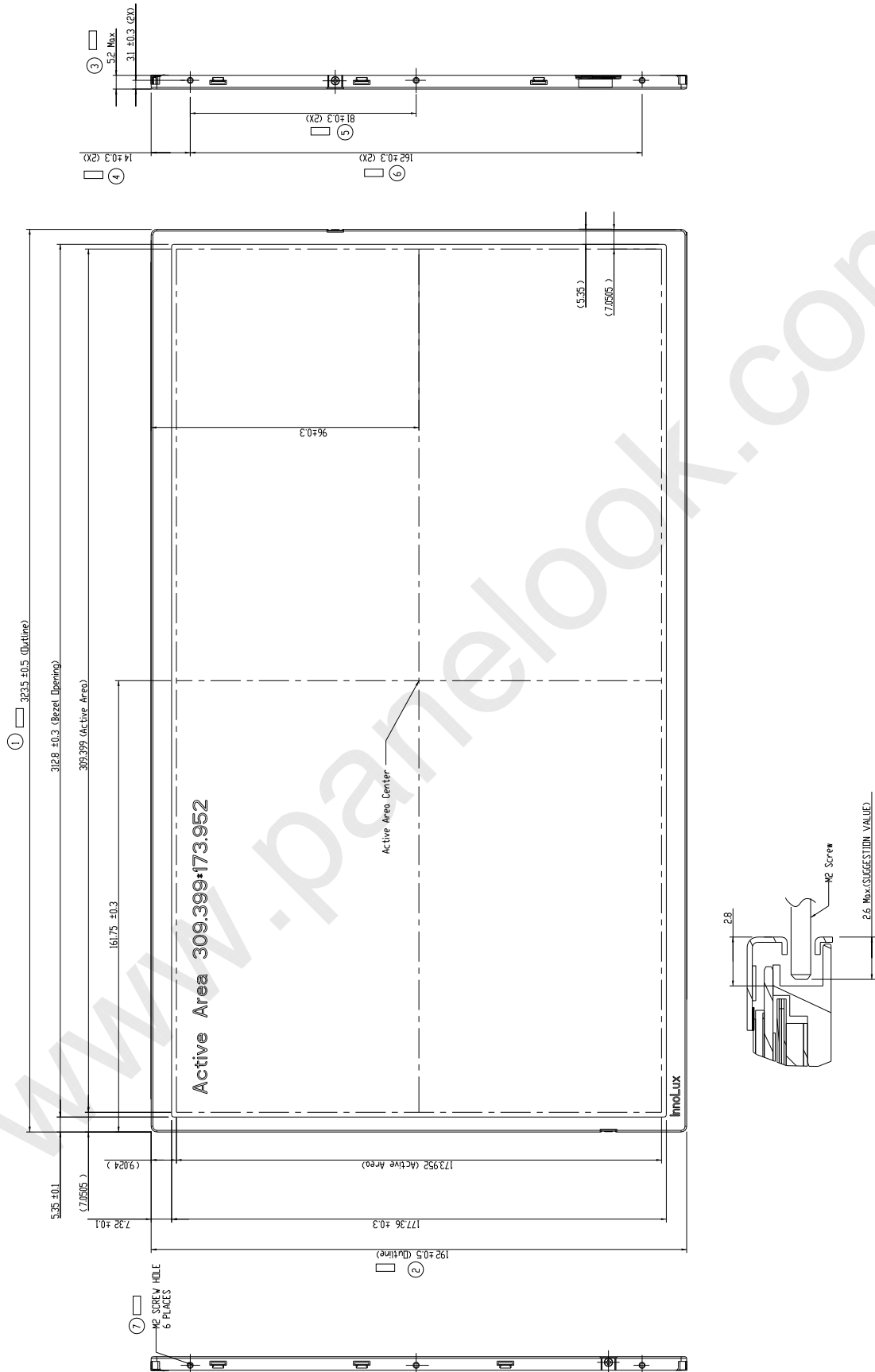

ALL RIGHTS STRICTLY RESERVED. ANY PORTION OF THIS DOCUMENT SHALL NOT BE REPRODUCED, COPIED, OR TRANSFORMED TO ANY OTHER FORMS WITHOUT PERMISSION FROM Chimei-Innolux

10-2 Rear side

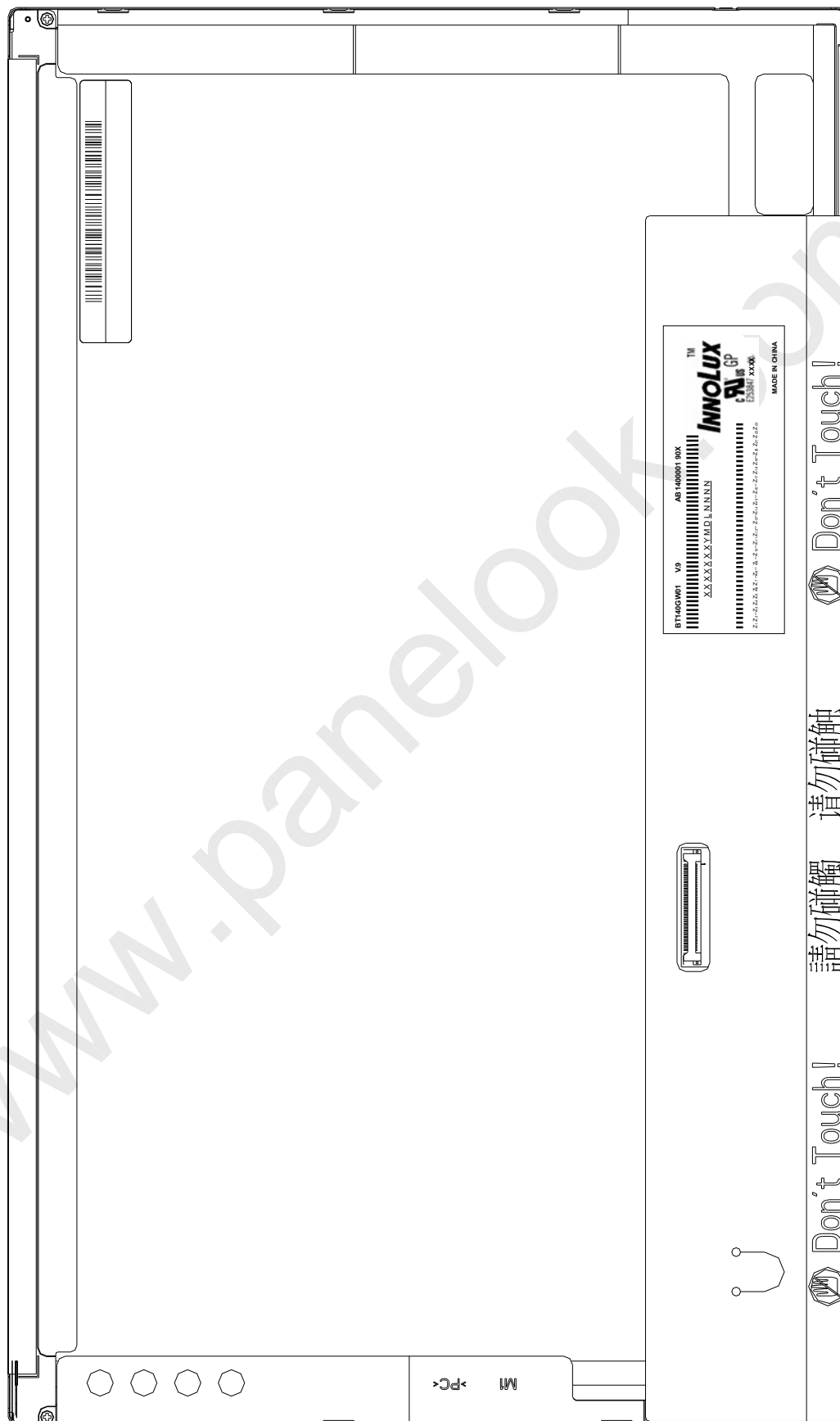

Appendix: EDID Code

	Byte (Hex)	Field Name and Comments	Value (Hex)	Value (Bin)
<i>Header</i>	00	Header	00	00000000
	01	Header	FF	11111111
	02	Header	FF	11111111
	03	Header	FF	11111111
	04	Header	FF	11111111
	05	Header	FF	11111111
	06	Header	FF	11111111
	07	Header	00	00000000
<i>Vendor / Product EDID Version</i>	08	EISA manufacture code (3 Character ID) " CMI"	0D	00001101
	09	EISA manufacture code (Compressed ASC II)	A9	10101001
	0A	Panel Supplier Reserved - Product Code "27"	1B	00000000
	0B	(Hex. LSB first)	00	00000000
	0C	LCD Module Serial No - Preferred but Optional ("0" If not used)	00	00000000
	0D	LCD Module Serial No - Preferred but Optional ("0" If not used)	00	00000000
	0E	LCD Module Serial No - Preferred but Optional ("0" If not used)	00	00000000
	0F	LCD Module Serial No - Preferred but Optional ("0" If not used)	00	00000000
	10	Week of Manufacture 00 weeks	00	00000000
	11	Year of Manufacture 2010 years	14	00010100
	12	EDID structure version # = 1	01	00000001
	13	EDID revision # = 3	03	00000011
<i>Display Parameters</i>	14	Video input Definition = Digital signal	80	10000000
	15	Max H image size (Rounded cm) = 31 cm	1F	00011111
	16	Max V image size (Rounded cm) = 18 cm	12	00010010
	17	Display gamma = (gamma*100)-100 = Example:(2.2*100)-100=120 = 2.2 Gamma	78	01111000
	18	Feature Support (no_DPMS, no_Active Off/Very Low Power, RGB color display, Timing BLK 1,no_GTF)	0A	00001010
<i>Panel Color Coordinates</i>	19	Red/Green Low Bits (RxRy/GxGy)	87	10000111
	1A	Blue/White Low Bits (BxBY/WxWy)	F5	11110101
	1B	Red X Rx = 0.580	94	10010100
	1C	Red Y Ry = 0.340	57	01010111
	1D	Green X Gx = 0.310	4F	01001111
	1E	Green Y Gy = 0.550	8C	10001100
	1F	Blue X Bx = 0.155	27	00100111
	20	Blue Y By = 0.155	27	00100111
	21	White X Wx = 0.313	50	01010000
	22	White Y Wy = 0.329	54	01010100

Established Timings	23	Established timing 1 (00h if not used)	00	00000000
	24	Established timing 2 (00h if not used)	00	00000000
	25	Manufacturer's timings (00h if not used)	00	00000000
Standard Timing ID	26	Standard timing ID1 (01h if not used)	01	00000001
	27	Standard timing ID1 (01h if not used)	01	00000001
	28	Standard timing ID2 (01h if not used)	01	00000001
	29	Standard timing ID2 (01h if not used)	01	00000001
	2A	Standard timing ID3 (01h if not used)	01	00000001
	2B	Standard timing ID3 (01h if not used)	01	00000001
	2C	Standard timing ID4 (01h if not used)	01	00000001
	2D	Standard timing ID4 (01h if not used)	01	00000001
	2E	Standard timing ID5 (01h if not used)	01	00000001
	2F	Standard timing ID5 (01h if not used)	01	00000001
	30	Standard timing ID6 (01h if not used)	01	00000001
	31	Standard timing ID6 (01h if not used)	01	00000001
	32	Standard timing ID7 (01h if not used)	01	00000001
	33	Standard timing ID7 (01h if not used)	01	00000001
	34	Standard timing ID8 (01h if not used)	01	00000001
35	Standard timing ID8 (01h if not used)	01	00000001	
Timing Descriptor #1	36	Pixel Clock/10,000 (LSB) 71 MHz @ 60Hz	BC	10111100
	37	Pixel Clock/10,000 (MSB)	1B	00011011
	38	Horizontal Active (lower 8 bits) 1366 Pixels	56	01010110
	39	Horizontal Blanking(Thp-HA) (lower 8 bits) 132 Pixels	84	10000100
	3A	Horizontal Active / Horizontal Blanking(Thp-HA) (upper 4:4bits)	50	01010000
	3B	Vertical Active 768 Lines	00	00000000
	3C	Vertical Blanking (Tvp-HA) (DE Blanking typ.for DE only panels) 22 Lines	16	00010110
	3D	Vertical Active : Vertical Blanking (Tvp-HA) (upper 4:4bits)	30	00110000
	3E	Horizontal Sync. Offset (Thfp) 48 Pixels	30	00110000
	3F	Horizontal Sync Pulse Width (HSPW) 32 Pixels	20	00100000
	40	Vertical Sync Offset(Tvfp) : Sync Width (VSPW) 1 Lines : 4 Lines	14	00010100
	41	Horizontal Vertical Sync Offset/Width (upper 2bits)	00	00000000
	42	Horizontal Image Size (mm) 309 mm	35	00110101
	43	Vertical Image Size (mm) 174 mm	AE	10101110
	44	Horizontal Image Size / Vertical Image Size	10	00010000
	45	Horizontal Border = 0 (Zero for Notebook LCD)	00	00000000
	46	Vertical Border = 0 (Zero for Notebook LCD)	00	00000000
47	Non-Interlace, Normal display, no stereo, Digital Separate (Vsync_NEG, Hsync_NEG), DE only note : LSB is set to '1' if panel is DE-timing only. H/V can be ignored.	18	00011000	

ALL RIGHTS STRICTLY RESERVED. ANY PORTION OF THIS DOCUMENT SHALL NOT BE REPRODUCED, COPIED, OR TRANSFORMED TO ANY OTHER FORMS WITHOUT PERMISSION FROM Chimei-Innolux

Timing Descriptor #2	48	Flag	00	00000000
	49	Flag	00	00000000
	4A	Flag	00	00000000
	4B	Data Type Tag (Descriptor Defined by manufacturer)	00	00000000
	4C	Flag	00	00000000
	4D	Descriptor Defined by manufacturer	20	00100000
	4E	Descriptor Defined by manufacturer	20	00100000
	4F	Descriptor Defined by manufacturer	20	00100000
	50	Descriptor Defined by manufacturer	20	00100000
	51	Descriptor Defined by manufacturer	20	00100000
	52	Descriptor Defined by manufacturer	20	00100000
	53	Descriptor Defined by manufacturer	20	00100000
	54	Descriptor Defined by manufacturer	20	00100000
	55	Descriptor Defined by manufacturer	20	00100000
	56	Descriptor Defined by manufacturer	20	00100000
	57	Descriptor Defined by manufacturer	20	00100000
	58	Descriptor Defined by manufacturer	20	00100000
59	Descriptor Defined by manufacturer	20	00100000	
Timing Descriptor #3	5A	Flag	00	00000000
	5B	Flag	00	00000000
	5C	Flag	00	00000000
	5D	Data Type Tag (ASCII String)	FE	11111110
	5E	Flag	00	00000000
	5F	ASCII String "C"	43	01000011
	60	ASCII String "M"	4D	01001101
	61	ASCII String "I"	49	01001001
	62	ASCII String	0A	00001010
	63	ASCII String	20	00100000
	64	ASCII String	20	00100000
	65	ASCII String	20	00100000
	66	ASCII String	20	00100000
	67	ASCII String	20	00100000
	68	ASCII String	20	00100000
	69	Manufacturer P/N(If<13 char--> 0Ah, then terminate with ASC II code 0Ah,set remaining char = 20h)	20	00100000
	6A	Manufacturer P/N(If<13 char--> 0Ah, then terminate with ASC II code 0Ah,set remaining char = 20h)	20	00100000
6B	Manufacturer P/N(If<13 char--> 0Ah, then terminate with ASC II code 0Ah,set remaining char = 20h)	20	00100000	

<i>Timing Descriptor #4</i>	6C	Flag	00	00000000
	6D	Flag	00	00000000
	6E	Flag	00	00000000
	6F	Data Type Tag (ASCII String)	FE	11111100
	70	Flag	00	00000000
	71	Monitor Name, stored as ASCII "B"	42	01000010
	72	Monitor Name, stored as ASCII "T"	54	01010100
	73	Monitor Name, stored as ASCII "I"	31	00110001
	74	Monitor Name, stored as ASCII "4"	34	00110100
	75	Monitor Name, stored as ASCII "0"	30	00110000
	76	Monitor Name, stored as ASCII "G"	47	01000111
	77	Monitor Name, stored as ASCII "W"	57	01010111
	78	Monitor Name, stored as ASCII "0"	30	00110000
	79	Monitor Name, stored as ASCII "1"	31	00110011
	7A	Monitor Name, stored as ASCII "V"	56	01010110
7B	Monitor Name, stored as ASCII "9"	39	00110100	
7C	Monitor Name, stored as ASCII	0A	00001010	
7D	Monitor Name, stored as ASCII	20	00100000	
<i>Checksum</i>	7E	Extension flag (# of optional 128 panel ID extension block to follow, Typ = 0)	00	00000000
	7F	Check Sum (The 1-byte sum of all 128 bytes in this panel ID block shall = 0)	6E	01101110