



Chimei-Innolux Corporation

BT140GW04 V.2 LCD MODULE SPECIFICATION

Preliminary Specification

Final Specification

Customer	Checked & Approved by
Lenovo	

Approved by	Checked by	Prepared by
MKT	PD	PM
		Monica Huang

Date: 2010/03/ 31

Chimei-Innolux Corporation

No.160 Kesyue Rd., Chu-Nan Site, Hsinchu Science Park,

Chu-Nan 350, Miao-Li County, Taiwan

Tel: 886-37-586000

Fax: 886-37-586060



Version: 3

Chimei-Innolux copyright
All rights reserved,
Copying forbidden.

Record of Revision

Version	Revise Date	Page	Content
0	2010/03/18	All	First Edition issued
1	2010/03/19	12	Modify LED Forward Voltage
		12	Modify LED Life Time
		13	Modify White Uniformity
		14	Modify Note 7
		21/22	Modify 2D Drawing
2	2010/03/25		Update IIS
3	2010/03/29	7	Table 2-2
		14	LED Lifteimt
		15	Brightness
		21	Carton Label
		22	Packing Form
		23/24	Drawing
4	2010/03/31	5	Pin Assignment



SPEC NO. BT140GW04 V.2

PAGE 3/25

Contents:	Page
1. General Specifications	2
2. Electrical Specifications	
2-1 Pin Assignment	3
2-2 Absolute Maximum Ratings	5
2-3 Electrical Characteristics	6
3. Optical Specifications	12
4. Reliability Test Items	16
5. Safety	17
6. Display Quality	17
7. Handling Precaution	17
8. Label Definition	18
9. Packing Form	20
10. Mechanical Drawings	21
Appendix	23



SPEC NO. BT140GW04 V.2

PAGE 4/25

1. General Specifications

NO.	Item	Specification	Unit
1	Display resolution (pixel)	1366(H) X 768(V), HD resolution	
2	Active area	309.40(H) X 173.95(V)	mm
3	Screen size	14.0 inches diagonal	Inches
4	Pixel pitch	0.2265(H) X 0.2265(V)	mm
5	Color configuration	Stripe	
6	Overall dimension	320.9(W) X 199.1(H) X 3.6(D) (max)	mm
7	Weight	320Max.	Grams
8	Surface treatment	AG, 3H	
9	Input color signal	6 bit LVDS	
10	Display colors	262K (6 bit)	
11	Optimum viewing direction	6 o'clock	
12	Backlight	W-LED	
13	RoHS	RoHS compliance	

2. Electrical Specifications

2-1 Pin Assignment

a. Panel connector

Connector Part No: GS13401-1110S-7H (Foxconn)

User's connector Part No: 20453-040T-12 (I-PEX) or equivalent

Pin No	Symbol	Description	Remark
1	NC	No connection (Reserve)	
2	V _{CC}	Power Supply (+3.3V)	
3	V _{CC}	Power Supply (+3.3V)	
4	V _{EDID}	DDC Power +3.3V	
5	NC	No connection (Reserve)	
6	Clk _{EDID}	DDC Clock	
7	DATA _{EDID}	DDC Data	
8	Rxin0-	Differential Data Input	R0~R5,G0
9	Rxin0+	Differential Data Input	
10	GND	Ground	
11	Rxin1-	Differential Data Input	G1~G5,B0,B1
12	Rxin1+	Differential Data Input	
13	GND	Ground	
14	Rxin2-	Differential Data Input	B2~B5,DE,Hsync,Vsync
15	Rxin2+	Differential Data Input	
16	GND	Ground	
17	CLK-	Differential Clock Input	
18	CLK+	Differential Clock Input	
19	NC	No connection (Reserve)	
20	NC	No connection (Reserve)	
21	NC	No connection (Reserve)	
22	GND	Ground	
23	NC	No connection (Reserve)	
24	NC	No connection (Reserve)	
25	GND	Ground	
26	NC	No connection (Reserve)	
27	NC	No connection (Reserve)	
28	GND	Ground	
29	NC	No connection (Reserve)	
30	NC	No connection (Reserve)	
31	LED_GND	LED Ground	
32	LED_GND	LED Ground	
33	LED_GND	LED Ground	
34	NC	No connection (Reserve)	
35	LED_PWM	PWM dimming signal input	
36	LED_EN	LED enable pin (3.3V)	
37	NC	No connection (Reserve)	
38	V_LED	LED power supply 7.5V~21V	
39	V_LED	LED power supply 7.5V~21V	
40	V_LED	LED power supply 7.5V~21V	



SPEC NO. BT140GW04 V.2

PAGE 6/25

b. General Block Diagram (Rear Side)



Connector P/N :
GS13401-1110S-7H

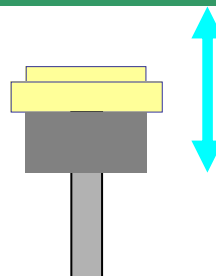
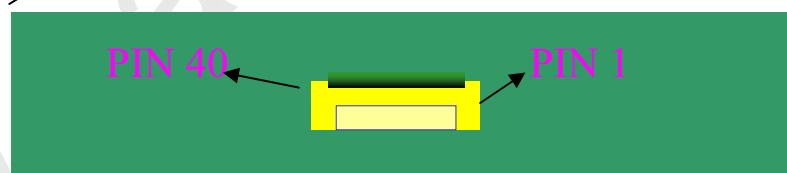

2-2. Absolute Maximum Ratings

Parameter	Symbol	Values		Unit	Remark
		Min.	Max.		
Power input voltage	V_{CC}	- 0.3	4.0	V	At 25°C
Signal input voltage	V_{IN}	- 0.3	4.0	V	At 25°C
Operating temperature	T_{OP}	0	50	°C	Note 1
Storage temperature	T_{ST}	- 20	60	°C	Note 2

Note 1: The relative humidity must not exceed 90% non-condensing at temperatures of 40°C or less. At temperatures greater than 40°C, the wet bulb temperature must not exceed 39°C.

Note 2: The unit should not be exposed to corrosive chemicals.

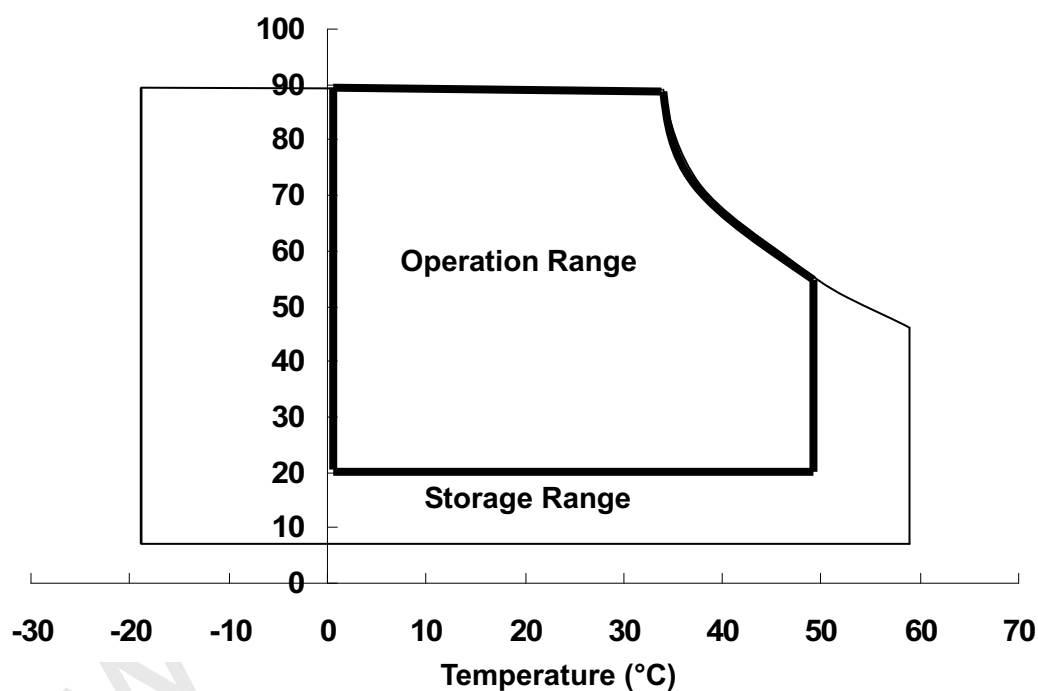
Relative Humidity (%RH)

2-3. Electrical Characteristics

a. Typical operating conditions

Item	Symbol	Min.	Typ.	Max.	Unit	Remark	
Power input voltage	V_{CC}	3	3.3	3.6	V		
Permissive power input ripple	V_{RF}	-	-	0.1	V		
Power input current	I_{CC}	-	300	340	mA	Note 1	
Power consumption	P_C	-		TBD	Watts	Note 1	
LVDS interface	Differential input high threshold voltage	V_{LVTH}	-	-	+100	mV	LVDS interface
	Differential input low threshold voltage	V_{LVTL}	-100	-	-	mV	
	Common input voltage	V_{LVC}	1.0	1.2	1.4	V	
	Terminating resistor	R_T	90	100	110	ohm	
Rush current	I_{Rush}	-	-	1.5	A	Note 3	
LED rush current	$I_{LED-Rush}$	-	-	3.0	A	Note 4	

Note 1: The specified input current and power consumption are under the $V_{CC} = 3.3$ V, 25°C , $f_V = 60$ Hz (frame frequency) condition whereas black pattern is displayed.

Note 2: LVDS waveform diagram

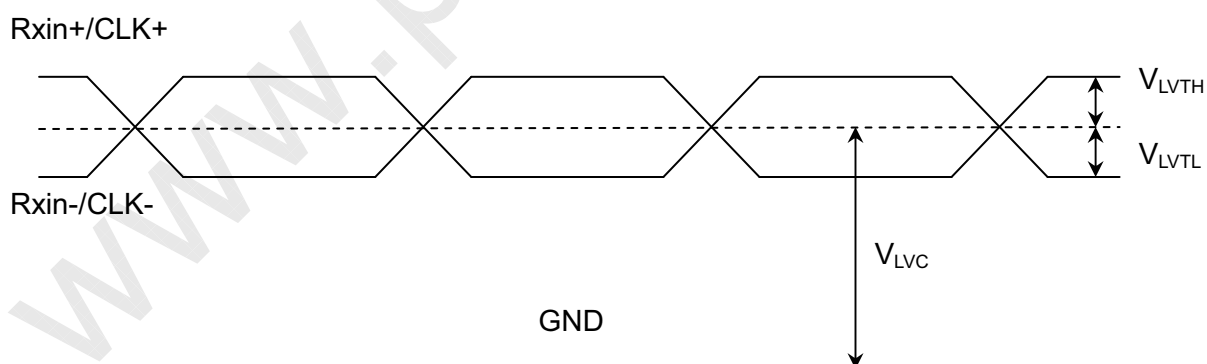

SPEC NO. BT140GW04 V.2

PAGE

9/25

Note 3: Test condition

(1) Pattern: Black pattern

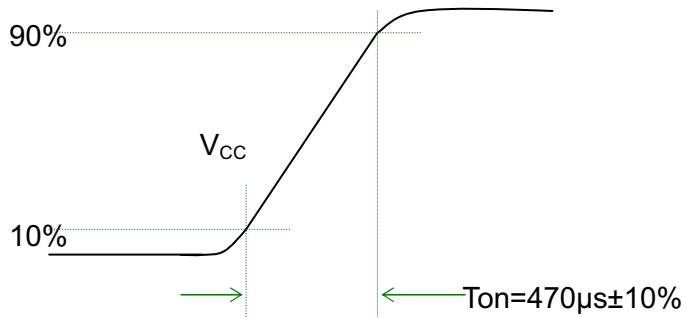
(2) $V_{CC} = 3.3\text{ V}$, V_{CC} rising time = $470\ \mu\text{s} \pm 10\%$ 

(3) Test circuit

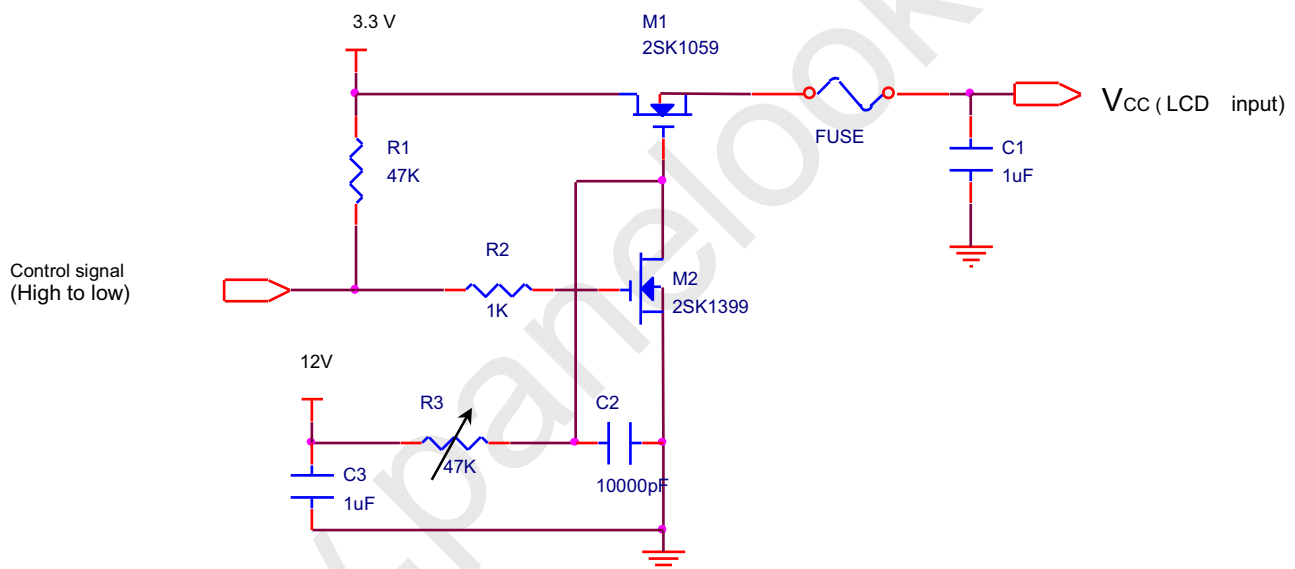

Note 4: Test condition

(1) Pattern: LED duty 100%

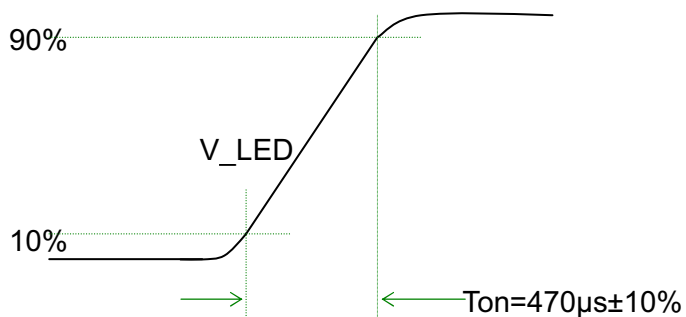
(2) $V_{LED} = 12.0V$, V_{LED} rising time = $470 \mu s \pm 10\%$ 

(3) Test circuit

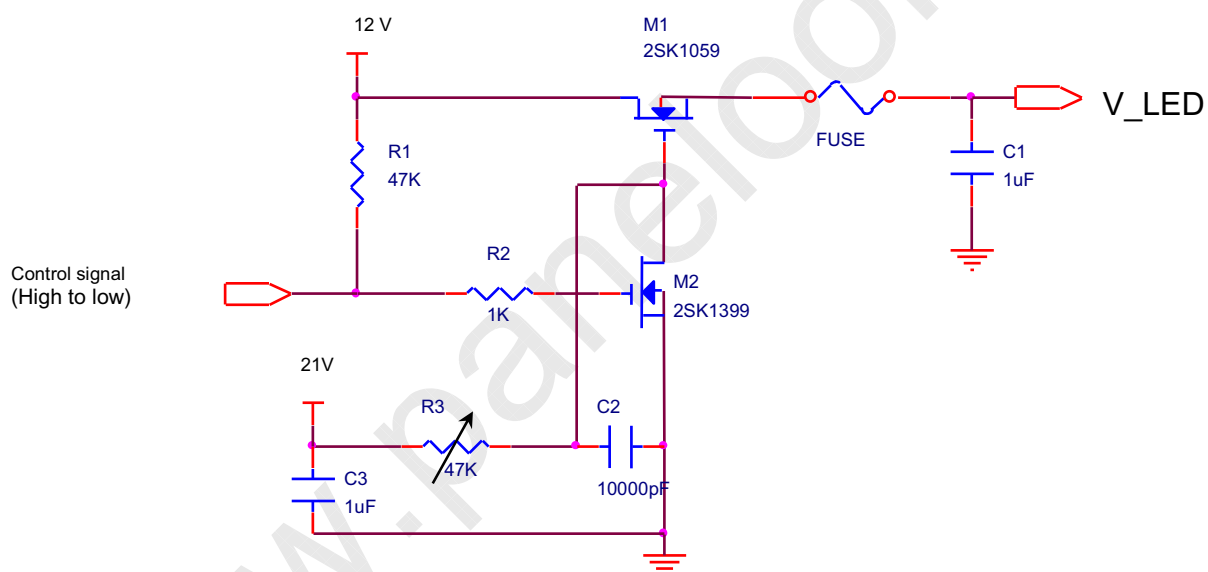

b. Power sequence

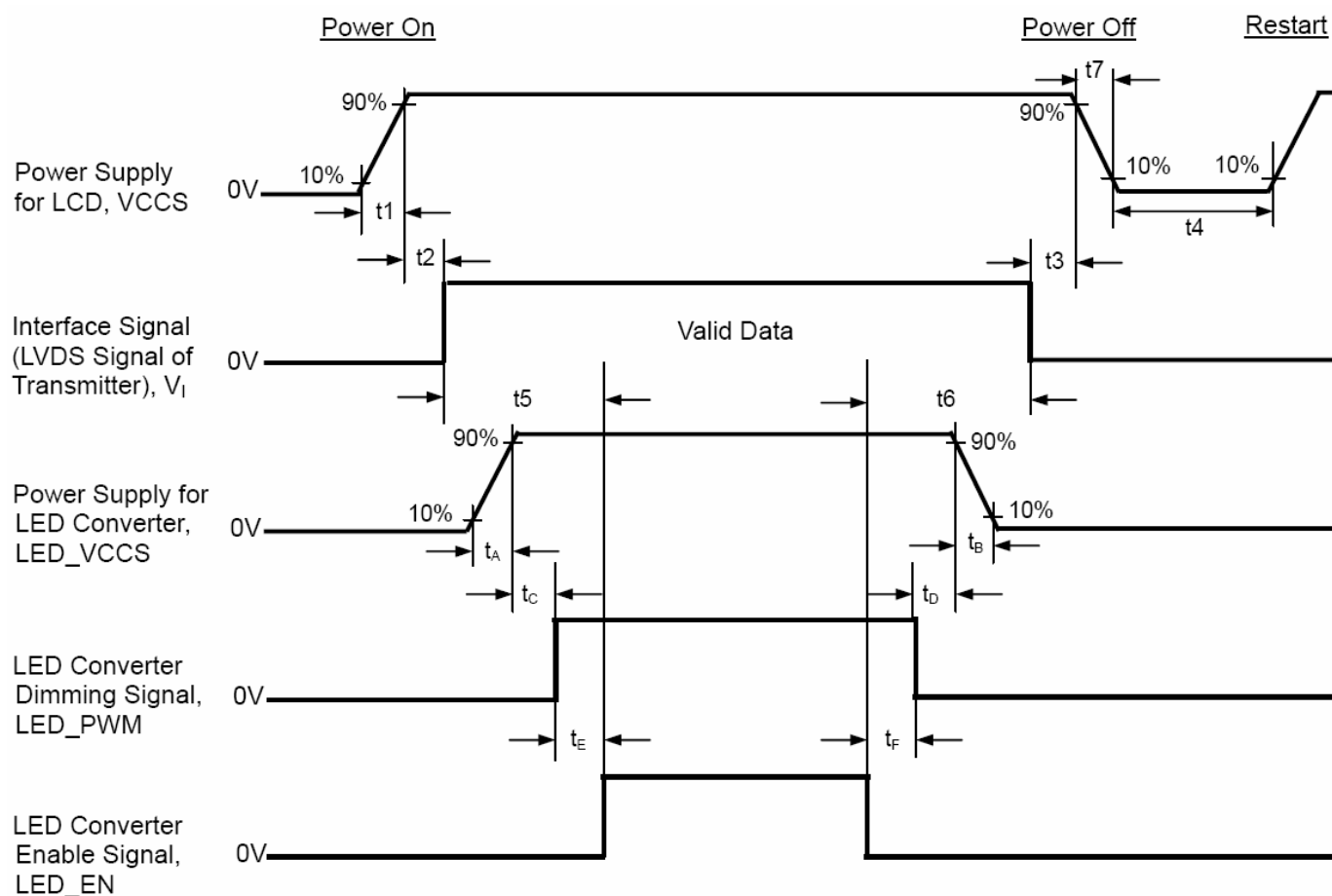

Power sequence timing table

Parameter	Value			Units
	Min.	Typ.	Max.	
t ₁	≥ 0.5	--	≤ 10	ms
t ₂	≥ 0	--	≤ 50	ms
t ₃	≥ 0	--	--	ms
t ₄	≥ 150	--	--	ms
t ₅	≥ 200	---	--	ms
t ₆	≥ 0	--	--	ms
t ₇	≥ 0	--	≤ 10	ms
t _A	≥ 0.5	--	≤ 10	ms
t _B	> 0	--	--	ms
t _C	≥ 0	--	--	ms
t _D	≥ 0	--	--	ms
t _E	≥ 0	--	--	ms
t _F	≥ 0	--	--	ms

c. Display color vs. input data signals

Signal Name	Description	Remark
R5	Red Data 5 (MSB)	Red-pixel data. Each red pixel's brightness data consists of these 6 bits pixel data.
R4	Red Data 4	
R3	Red Data 3	
R2	Red Data 2	
R1	Red Data 1	
R0	Red Data 0 (LSB)	
	Red-pixel Data	
G5	Green Data 5 (MSB)	Green-pixel data. Each green pixel's brightness data consists of these 6 bits pixel data.
G4	Green Data 4	
G3	Green Data 3	
G2	Green Data 2	
G1	Green Data 1	
G0	Green Data 0 (LSB)	
	Green-pixel Data	
B5	Blue Data 5 (MSB)	Blue-pixel data. Each blue pixel's brightness data consists of these 6 bits pixel data.
B4	Blue Data 4	
B3	Blue Data 3	
B2	Blue Data 2	
B1	Blue Data 1	
B0	Blue Data 0 (LSB)	
	Blue-pixel Data	

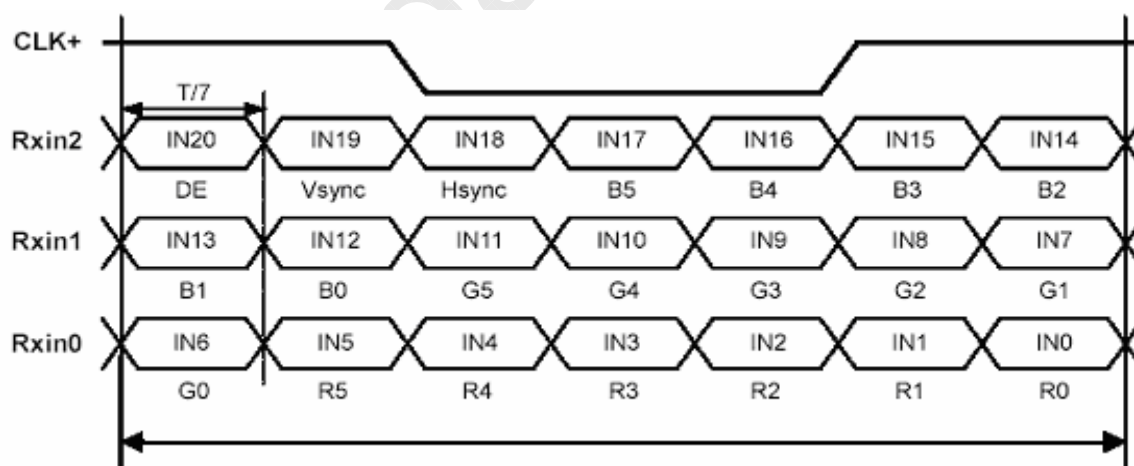
Signal for 1 DCLK cycle (t_{CLK})

SPEC NO. BT140GW04 V.2

PAGE

13/25

d. Input signal timing

Timing table

Refresh rate 60Hz

Signal	Item	Symbol	Min.	Typ.	Max.	Unit	Note
DCLK	Frequency	1/Tc	62.4	69.3	72.8	MHz	-
DE	Vertical Total Time	TV	776	788	793	TH	-
	Vertical Active Display Period	TVD	768	768	768	TH	-
	Vertical Active Blanking Period	TVB	TV-TVD	20	TV-TVD	TH	
	Horizontal Total Time	TH	1456	1466	1492	Tc	-
	Horizontal Active Display Period	THD	1366	1366	1366	Tc	-
	Horizontal Active Blanking Period	THB	TH-THD	100	TH-THD	Tc	

Refresh rate 50Hz

Signal	Item	Symbol	Min.	Typ.	Max.	Unit	Note
DCLK	Frequency	1/Tc	57.418	60.44	63.462	MHz	-
DE	Vertical Total Time	TV	776	788	793	TH	-
	Vertical Active Display Period	TVD	768	768	768	TH	-
	Vertical Active Blanking Period	TVB	TV-TVD	20	TV-TVD	TH	
	Horizontal Total Time	TH	1523	1534	1561	Tc	-
	Horizontal Active Display Period	THD	1366	1366	1366	Tc	-
	Horizontal Active Blanking Period	THB	TH-THD	168	TH-THD	Tc	

Refresh rate 40Hz

Signal	Item	Symbol	Min.	Typ.	Max.	Unit	Note
DCLK	Frequency	1/Tc	45.93	48.35	50.77	MHz	
DE	Vertical Total Time	TV	776	788	793	TH	
	Vertical Active Display Period	TVD	768	768	768	TH	
	Vertical Active Blanking Period	TVB	TV-TVD	20	TV-TVD	TH	
	Horizontal Total Time	TH	1523	1534	1561	Tc	
	Horizontal Active Display Period	THD	1366	1366	1366	Tc	
	Horizontal Active Blanking Period	THB	TH-THD	168	TH-THD	Tc	

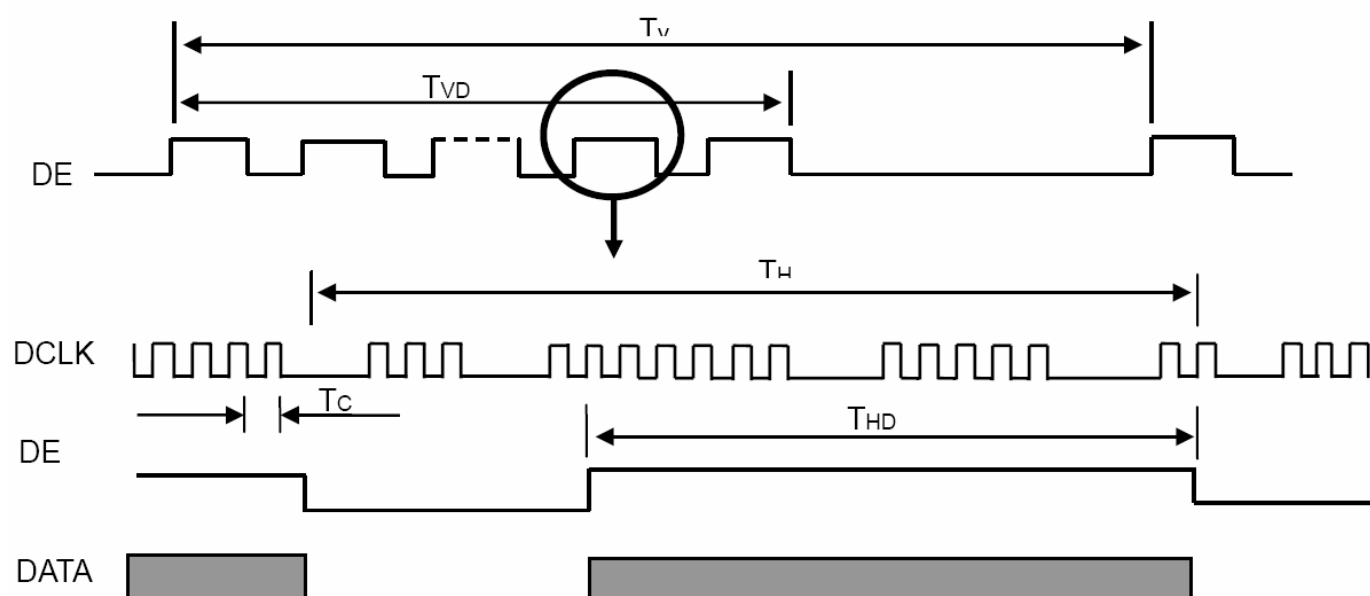
INPUT SIGNAL TIMING DIAGRAM

ALL RIGHTS STRICTLY RESERVED. ANY PORTION OF THIS DOCUMENT SHALL NOT BE REPRODUCED, COPIED, OR TRANSFORMED TO ANY OTHER FORMS WITHOUT PERMISSION FROM Chimei-Innolux.

SPEC NO. BT140GW04 V.2

PAGE 14/25

e. Display position

D(1, 1)	D(2, 1)	D(683, 1)	D(1365, 1)	D(1366, 1)
D(1, 2)	D(2, 2)	D(683, 2)	D(1365, 2)	D(1366, 2)
⋮		⋮	⋮	⋮
D(1, 384)	D(2, 384)	D(683, 384)	D(1365, 384)	D(1366, 384)
⋮		⋮	⋮	⋮
D(1, 767)	D(2, 767)	D(683, 767)	D(1365, 767)	D(1366, 767)
D(1, 768)	D(2, 768)	D(683, 768)	D(1365, 768)	D(1366, 768)

f. Backlight driving conditions

Parameter	Symbol	Min.	Typ.	Max.	Unit	Remark
LED Forward Voltage	V_F	3	3.2	3.4	V_{rms}	$T = 25^\circ C$
LED Forward Current	I_F		20		mA_{rms}	$T = 25^\circ C$
Power consumption	P_{LED}			3.0	W	$T = 25^\circ C$
Input PWM frequency	F_{PWM}	100		2000	Hz	$T = 25^\circ C$
Duty ratio	-	1		100	%	Note 1
LED life time	-	15,000			Hr	$T = 25^\circ C$, Note 2

Note 1: PWM duty ratio linearity guarantees 20~100%

Note 2: LED life time definition is Brightness decrease to 50% of initial or abnormal lighting.

g. Module function block

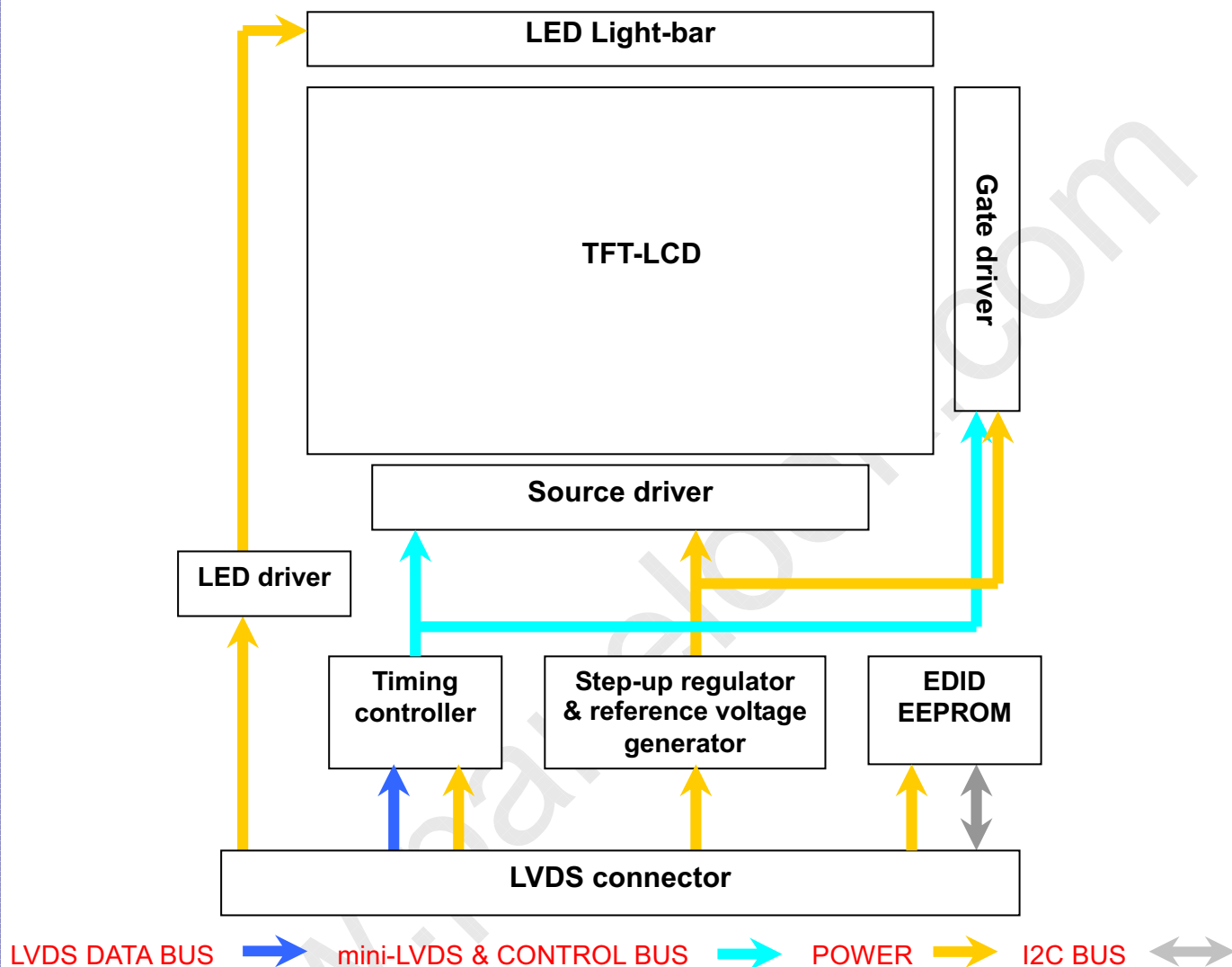

3. Optical specifications

Ambient temperature = 25°C

Item	Symbol	Condition	Specification			Unit	Remark
			Min.	Typ.	Max.		
Response time	Tr+Tf	$\theta = 0^\circ$		8	16	ms	Note 3
Contrast ratio	CR	$\theta = 0^\circ$		500			Note 2,4
Viewing angle	Top	$CR \geq 10$	15			deg	Note 2,4,6
	Bottom	$CR \geq 10$	30				
	Left	$CR \geq 10$	40				
	Right	$CR \geq 10$	40				
Brightness (5 points average)	Y_L		(170)	200		nit	Note 2,5
Color chromaticity (CIE)	W_x	$\theta = 0^\circ$	-0.03	0.313	+0.03		Note 2
	W_y			0.329			
	R_x			0.580			
	R_y			0.340			
	G_x			0.310			
	G_y			0.55			
	B_x			0.155			
	B_y			0.155			
Color Gamut	NTSC	CIE1931		45		%	-
White uniformity	$\delta_{W(5)}$		0.8				Note 2,7
	$\delta_{W(13)}$		0.6				
Cross talk	Ct				2%		Note 8

Note 1: To be measured in dark room.

Note 2: To be measured with a viewing cone of 2° by Topcon luminance meter BM-5A.

Note 3: Definition of response time:

The output signals of BM-7 are measured when the input signals are changed from "Black" to "White" (falling time) and from "White" to "Black" (rising time), respectively. The response time interval is between 10% and 90% of amplitudes. Refer to figure as below.

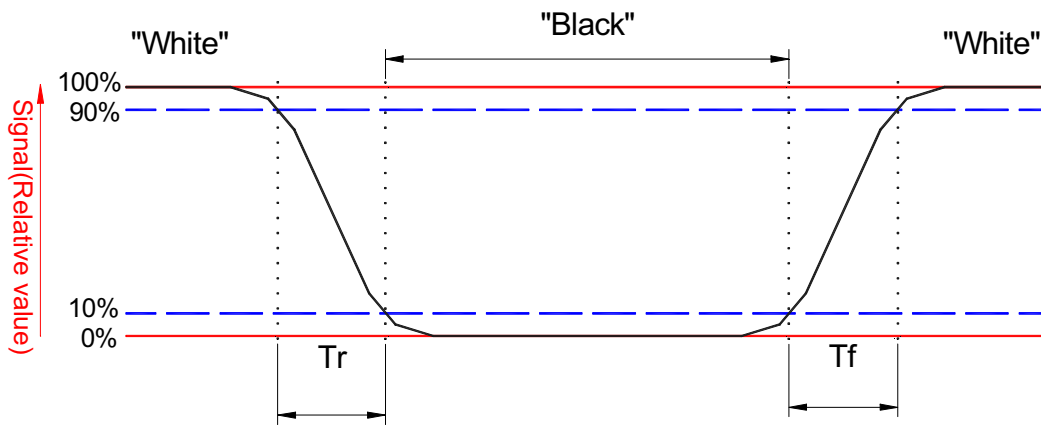

Note 4: Definition of contrast ratio:

Contrast ratio is calculated with the following formula:

$$\text{Contrast ratio (Avg of 5pts)} = \frac{L_{\text{white (Avg of 5pts.)}}}{L_{\text{Black (Avg of 5pts.)}}}$$

Note 5: Driving current for LED should be 20 mA.

Luminance is measured at the following thirteen points (1~13):

$$Y_L = (Y_3 + Y_5 + Y_7 + Y_{11} + Y_{12}) / 5$$

Note 6: Definition of viewing angle

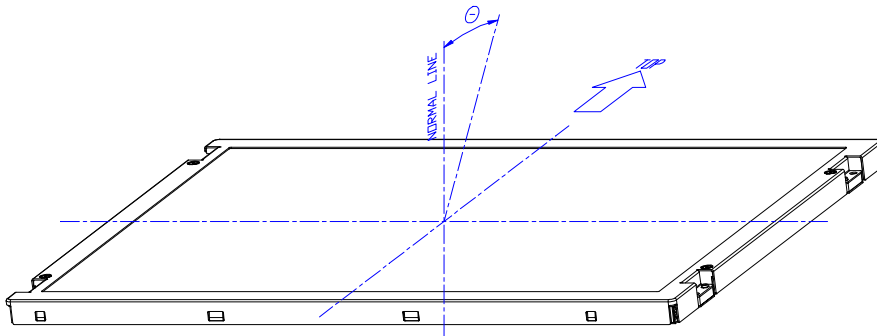

Note 7: Definition white uniformity

Luminance is measured at the following thirteen points (1~13):

$$\delta_{w(13)} = \text{Minimum} [L(1) \sim L(13)] / \text{Maximum} [(L(1) \sim L(13))] * 100\%$$

$$\delta_{w(5)} = \text{Minimum} [L(1) \sim L(5)] / \text{Maximum} [(L(1) \sim L(5))] * 100\%$$

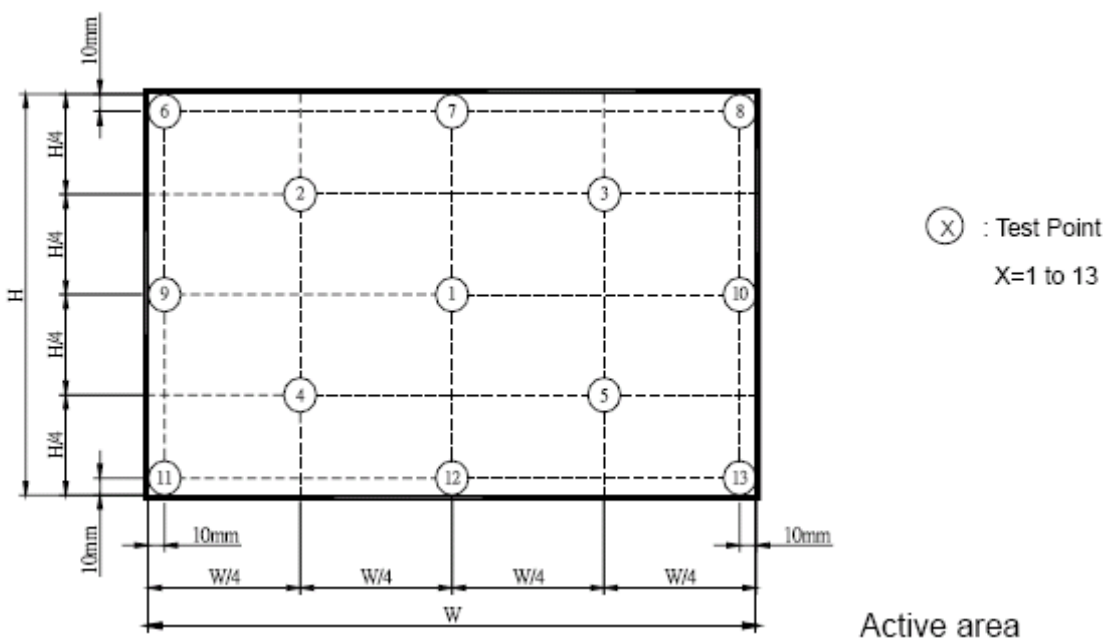

Note 8:

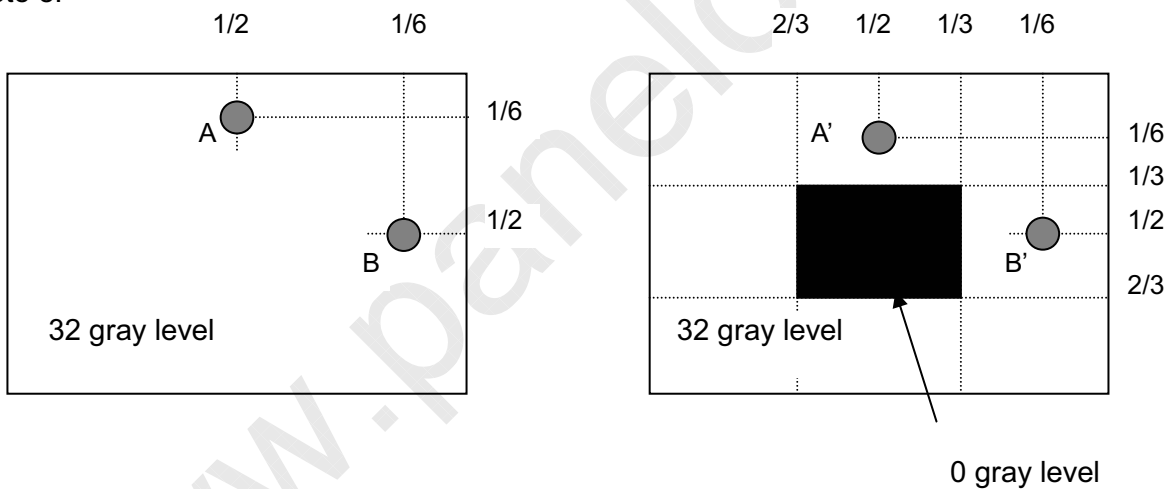

Unit: percentage of dimension of display area

$|L_A - L_{A'}| / L_A \times 100\% = 2\% \text{ max.}$, L_A and $L_{A'}$ are brightness at location A and A'

$|L_B - L_{B'}| / L_B \times 100\% = 2\% \text{ max.}$, L_B and $L_{B'}$ are brightness at location B and B'

4. Reliability test items

Test Item	Test Condition	Judgment	Remark
High temperature storage	60°C, 240 hours	Note 1	Note 2
Low temperature storage	-20°C, 240 hours	Note 1	Note 2
High temperature & high humidity operation	40°C, 90% RH, 240 hours (No condensation)	Note 1	Note 2
High temperature operation	50°C, 240 hours	Note 1	Note 2
Low temperature operation	0°C, 240 hours	Note 1	Note 2
Thermal Shock (Non-operation)	-25°C / 30 mins ~ 65°C / 30 mins 100 cycles	Note 1	Note 2
Electrostatic discharge (ESD)	150 pF, 330Ω, Contact: ±8kV, Air: ±15kV	Note 1	
Vibration (Non-operation)	1.5G, 10 to 500 Hz random; 0.5hr in each perpendicular axes (X, Y, Z).	Note 1	Note 2
Mechanical shock (Non-operation)	220G/2ms, Half sine wave, ±X, ±Y, ±Z one time for each direction	Note 1	Note 2

Note 1: Pass: Normal display image with no obvious non-uniformity and no line defect.

Fail: No display image, obvious non-uniformity, or line defects.

Partial transformation of the module parts should be ignored.

Note 2: Evaluation should be tested after storage at room temperature for more than one hour.

5. Safety

5-1. Sharp edge requirements

There will be no sharp edges or corners on the display assembly that could cause injury.

5-2. Materials

a. Toxicity

There will be no carcinogenic materials used anywhere in the display module. If toxic materials are

SPEC NO. BT140GW04 V.2

PAGE 20/25

used, they will be reviewed and approved by the responsible InnoLux Toxicologist.

b. Flammability

All components including electrical components that do not meet the flammability grade UL94-V0 in the module will complete the flammability rating exception approval process. The printed circuit board will be made from material rated 94-V0 or better. The actual UL flammability rating will be printed on the printed circuit board.

c. Capacitors

If any polarized capacitors are used in the display assembly, provisions will be made to keep them from being inserted backwards.

6. Display quality

The display quality of the color TFT-LCD module should be in compliance with the InnoLux incoming inspection standard.

7. Handling precaution

- (1) Do not apply rough force such as bending or twisting to the module during assembly.
- (2) To assemble or install module into user's system can be only in clean working areas. The dust and oil may cause electrical short or worsen the polarizer.
- (3) It's not permitted to have pressure or impulse on the module because the LCD panel and backlight will be damaged.
- (4) Always follow the correct power sequence when LCD module is connecting and operating.
- (5) Do not pull the I/F connector in or out while the module is operating.
- (6) Do not disassemble the module.
- (7) Use a soft dry cloth without chemicals for cleaning, because the surface of polarizer is very soft and easily scratched.
- (8) It is dangerous that moisture come into or contacted the LCD module, because moisture may damage LCD module when it is operating.
- (9) High temperature or humidity may reduce the performance of module. Please store LCD module within the specified storage conditions.

SPEC NO. BT140GW04 V.2

PAGE 21/25

8. Label Definition

8-1. Module label

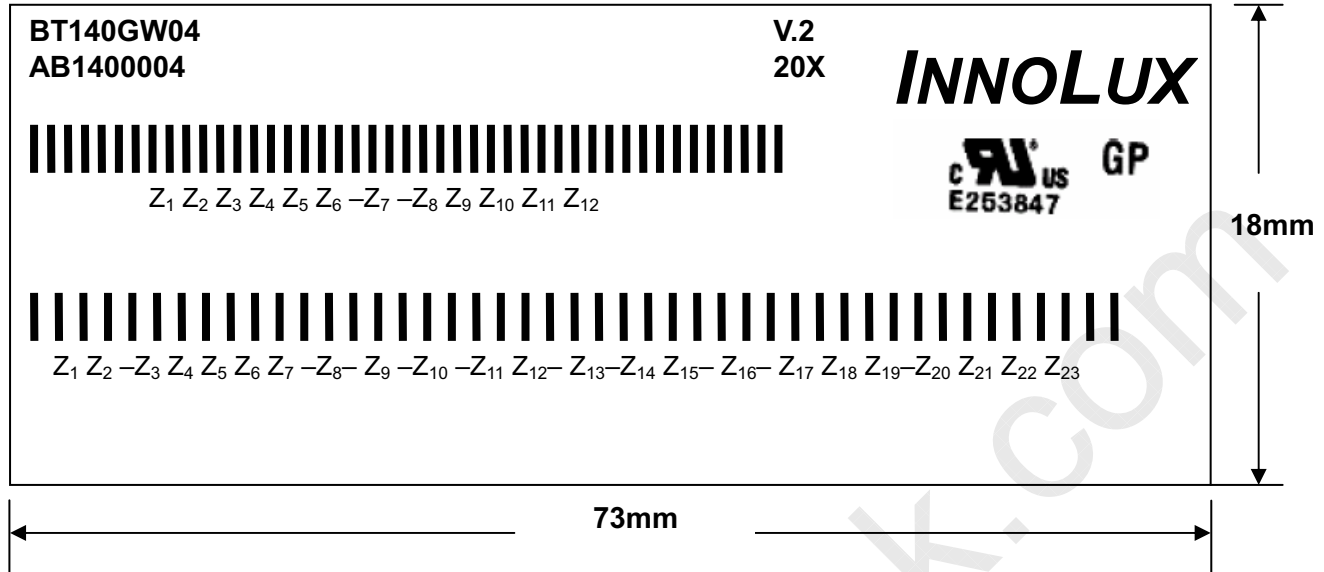

(1) Model Number : BT140GW04

(2) Version : V.2

(3) Product Number : AB140000420X

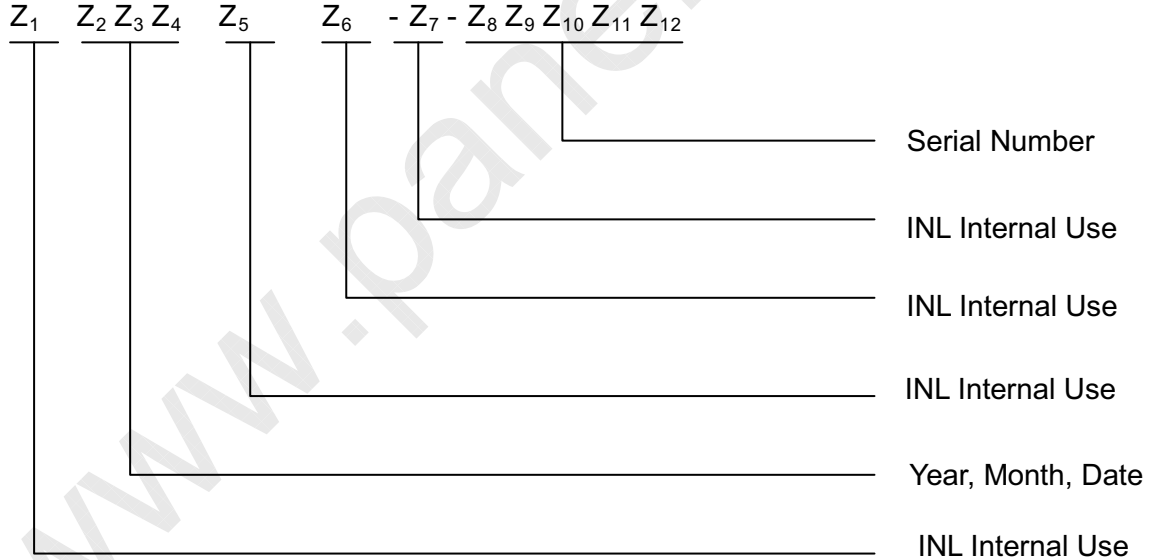
(4) Serial ID I (INL Internal Use): Z₁Z₂Z₃Z₄Z₅Z₆-Z₇-Z₈Z₉Z₁₀Z₁₁Z₁₂

Serial ID includes the information as below:

(a) Manufactured Date:

Year: 0~9, for 2000~2009;

Month: 1~9 & A~C for Jan.~Dec.;

Date: 1~9 & A~V for 1st~31st.

(b) Serial Number: Module packing sequence number

(5) Serial ID II (INL Internal Use):

Z₁ Z₂ -Z₃ Z₄ Z₅ Z₆ Z₇ -Z₈ -Z₉ -Z₁₀ -Z₁₁ Z₁₂ -Z₁₃ -Z₁₄ Z₁₅ -Z₁₆ -Z₁₇ Z₁₈ Z₁₉ -Z₂₀ Z₂₁ Z₂₂ Z₂₃

SPEC NO. BT140GW04 V.2

PAGE 22/25

8-2. Carton label

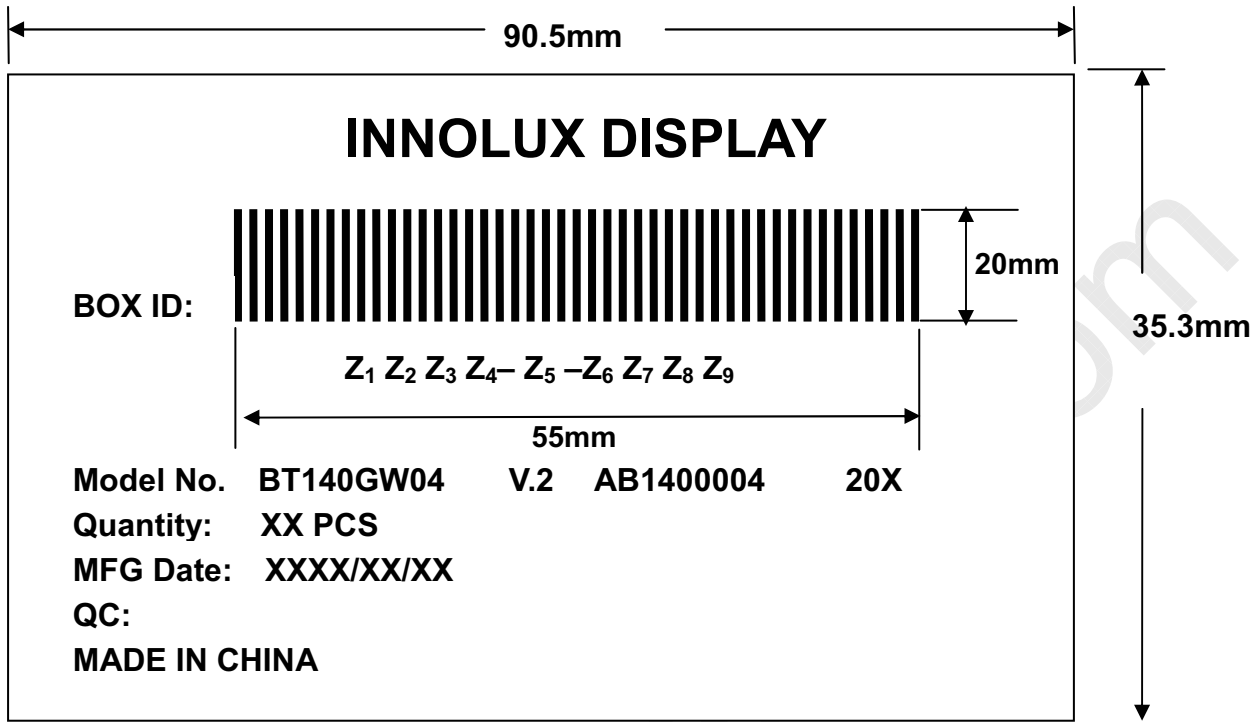

(1) Model No. : BT140GW04

(2) Version: V.2

(3) Package Quantity :XXPCS

(4) Serial ID:

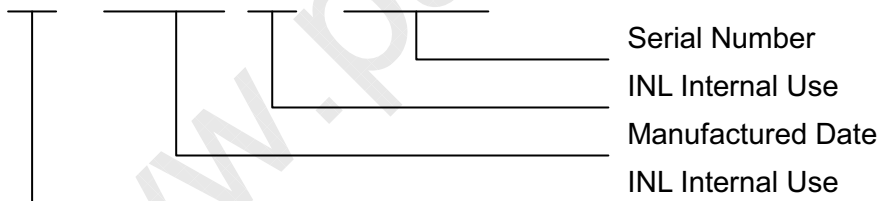
Z₁ Z₂ Z₃ Z₄- Z₅ -Z₆ Z₇ Z₈ Z₉

Serial ID includes the information as below:

(a) Manufactured Date:

Year: 0~9, for 2000~2009;

Month: 1~9 & A~C for Jan.~Dec.;

Date: 1~9 & A~V for 1st~31st.

(b) Serial Number: Module packing sequence number



9. Packing Form

↓ Step A
LCM



PET Tray

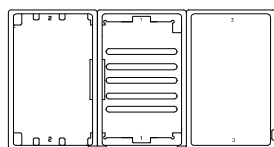

↓ Step B
Put LCM-1 into PET Tray

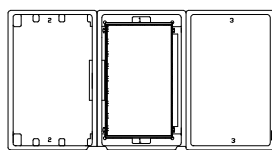

↓ Step C
Turn back PET Tray And
Put LCM-2 into PET Tray

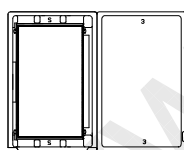

↓ Step D
Turn back the PET Tray

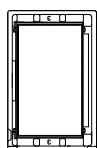

↙ Step E

Put LCM with PET Tray into carton

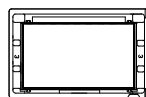

↓ Step F
upper cushion(1PCS)

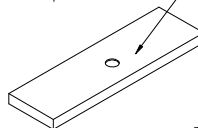

Carton
13 PCS
LCM(26PCS)

↓ Step G

Carton

↓ Step H

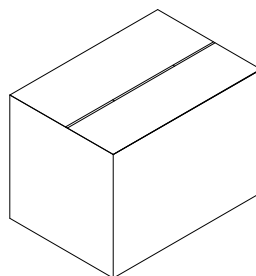



10. Mechanical Drawings

10-1 Front Side

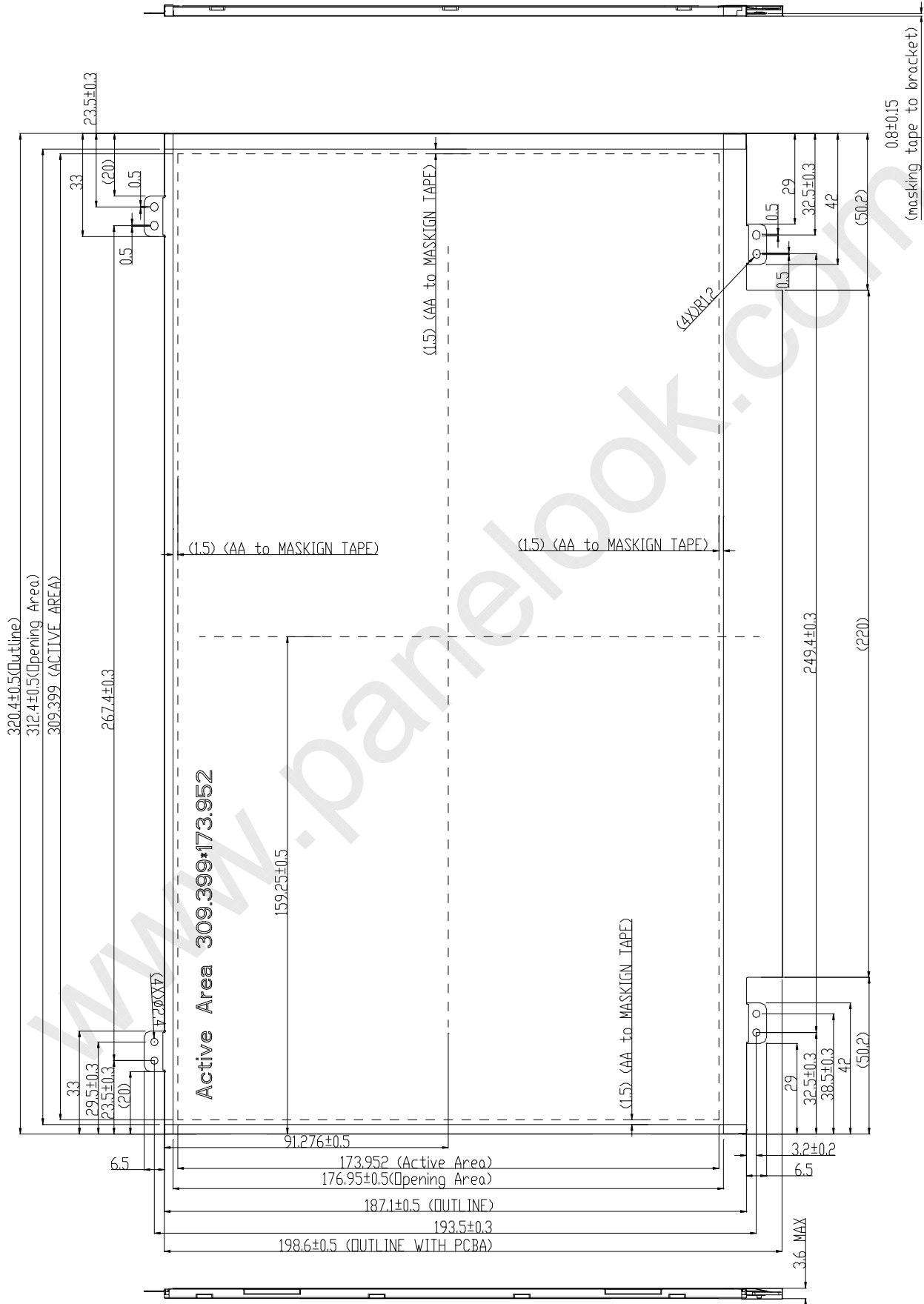



10-2 Rear side

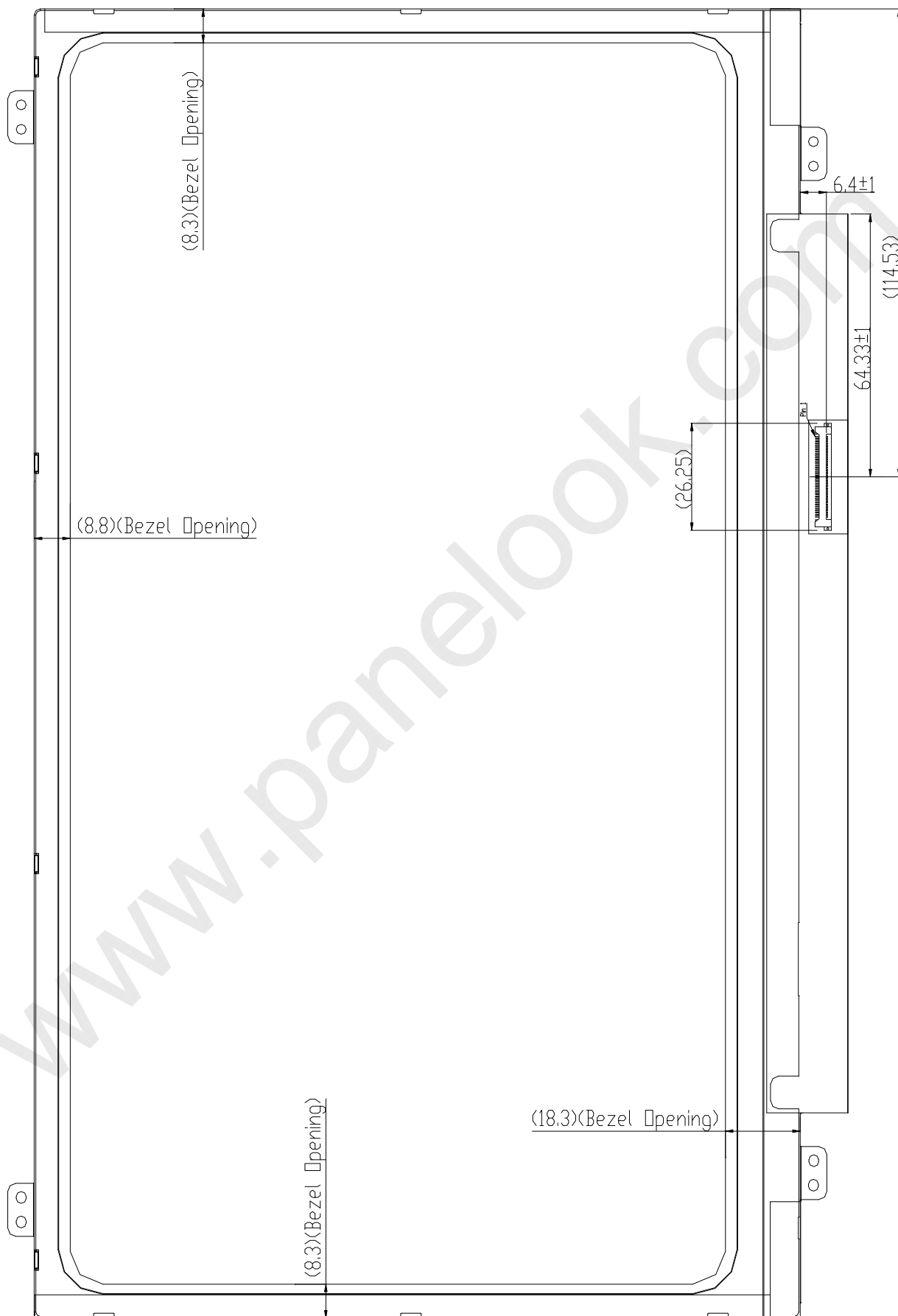

ALL RIGHTS STRICTLY RESERVED. ANY PORTION OF THIS DOCUMENT SHALL NOT BE REPRODUCED, COPIED, OR TRANSFORMED TO ANY OTHER FORMS WITHOUT PERMISSION FROM Chimei-Innolux.

11: EDID Code

	Byte	Field Name and Comments	Value
	(hex)		(hex)
Header	00	Header	00
	01	Header	FF
	02	Header	FF
	03	Header	FF
	04	Header	FF
	05	Header	FF
	06	Header	FF
	07	Header	00
Vendor / Product EDID Version	08	EISA manufacture code (3 Character ID) LEN"	30
	09	EISA manufacture code (Compressed ASC II)	AE
	0A	Panel Supplier Reserved - Product Code "14" 16:9 HD 1366x768 LED B/L"	A0
	0B	Panel Supplier Reserved - Product Code	40
	0C	ID Serial Number (32-bit serial number)	00
	0D	ID Serial Number (32-bit serial number)	00
	0E	ID Serial Number (32-bit serial number)	00
	0F	ID Serial Number (32-bit serial number)	00
	10	Week of Manufacture 00 weeks	00
	11	Year of Manufacture 2010 years	14
	12	EDID structure version # = 1	01
Display Parameters	13	EDID revision # = 3	03
	14	Video input Definition = Digital signal	80
	15	Max H image size (Rounded cm) = 31 cm	1F
	16	Max V image size (Rounded cm) = 18 cm	12
	17	Display gamma = (gamma*100)-100 = Example:(2.2*100)-100=120 = 2.2 Gamma	78
Panel Color Coordinates	18	Feature Support (Standby,Suspend,Active Off/Very Low Power, RGB color display,Preferred Timing Mode)	EA
	19	Red/Green Low Bits (RxRy/GxGy)	87
	1A	Blue/White Low Bits (BxBY/WxWy)	F5
	1B	Red X Rx = 0.580	94
	1C	Red Y Ry = 0.340	57
	1D	Green X Gx = 0.310	4F
	1E	Green Y Gy = 0.548	8C
	1F	Blue X Bx = 0.155	27
	20	Blue Y By = 0.155	27
	21	White X Wx = 0.313	50
22	White Y Wy = 0.329	54	

Established Timings	23	Established timing 1 (00h if not used)	00
	24	Established timing 2 (00h if not used)	00
	25	Manufacturer's timings (00h if not used)	00
Standard Timing ID	26	Standard timing ID1 (01h if not used)	01
	27	Standard timing ID1 (01h if not used)	01
	28	Standard timing ID2 (01h if not used)	01
	29	Standard timing ID2 (01h if not used)	01
	2A	Standard timing ID3 (01h if not used)	01
	2B	Standard timing ID3 (01h if not used)	01
	2C	Standard timing ID4 (01h if not used)	01
	2D	Standard timing ID4 (01h if not used)	01
	2E	Standard timing ID5 (01h if not used)	01
	2F	Standard timing ID5 (01h if not used)	01
	30	Standard timing ID6 (01h if not used)	01
	31	Standard timing ID6 (01h if not used)	01
	32	Standard timing ID7 (01h if not used)	01
	33	Standard timing ID7 (01h if not used)	01
	34	Standard timing ID8 (01h if not used)	01
35	Standard timing ID8 (01h if not used)	01	
Timing Descriptor #1	36	Pixel Clock/10,000 (LSB) 69.3 MHz @ 60Hz	12
	37	Pixel Clock/10,000 (MSB)	1B
	38	Horizontal Active (lower 8 bits) 1366 Pixels	56
	39	Horizontal Blanking(Thp-HA) (lower 8 bits) 100 Pixels	64
	3A	Horizontal Active / Horizontal Blanking(Thp-HA) (upper 4:4bits)	50
	3B	Vertical Avtive 768 Lines	00
	3C	Vertical Blanking (Tvp-HA) (DE Blanking typ.for DE only panels) 20 Lines	14
	3D	Vertical Active : Vertical Blanking (Tvp-HA) (upper 4:4bits)	30
	3E	Horizontal Sync. Offset (Thfp) 48 Pixels	30
	3F	Horizontal Sync Pulse Width (HSPW) 32 Pixels	20
	40	Vertical Sync Offset(Tvfp) : Sync Width (VSPW) 1 Lines : 4 Lines	14
	41	Horizontal Vertical Sync Offset/Width (upper 2bits)	00
	42	Horizontal Image Size (mm) 309 mm	35
	43	Vertical Image Size (mm) 174 mm	AE
	44	Horizontal Image Size / Vertical Image Size	10
	45	Horizontal Border = 0 (Zero for Notebook LCD)	00
	46	Vertical Border = 0 (Zero for Notebook LCD)	00
47	Non-Interlace, Normal display, no stereo, Digital Separate (Non-interlaced,Normal display,no stereo,Vertical Polarity Negative,Horizontal Polarity Negative)	18	

Timing Descriptor #2	48	Pixel Clock/10,000 (LSB)	60.44 MHz @ 50Hz	9C
	49	Pixel Clock/10,000 (MSB)		17
	4A	Horizontal Active (lower 8 bits)	1366 Pixels	FE
	4B	Horizontal Blanking(Thp-HA) (lower 8 bits)	177 Pixels	56
	4C	Horizontal Active / Horizontal Blanking(Thp-HA) (upper 4:4bits)		55
	4D	Vertical Avtive	768 Lines	14
	4E	Vertical Blanking (Tvp-HA) (DE Blanking typ.for DE only panels) 20 Lines		00
	4F	Vertical Active : Vertical Blanking (Tvp-HA) (upper 4:4bits)		33
	50	Horizontal Sync. Offset (Thfp)	48 Pixels	30
	51	Horizontal Sync Pulse Width (HSPW)	32 Pixels	20
	52	Vertical Sync Offset(Tvfp) : Sync Width (VSPW) 1 Lines : 4 Lines		14
	53	Horizontal Vertical Sync Offset/Width (upper 2bits)		00
	54	Horizontal Image Size (mm)	309 mm	35
	55	Vertical Image Size (mm)	174 mm	AE
	56	Horizontal Image Size / Vertical Image Size		10
	57	Horizontal Border = 0 (Zero for Notebook LCD)		00
	58	Vertical Border = 0 (Zero for Notebook LCD)		00
	59	Non-Interlace, Normal display, no stereo, Digital Separate (Non-interlaced,Normal display,no stereo,Vertical Polarity Negative,Horizontal Polarity Negative)		18
	Timing Descriptor #3 Dell specific information	5A	Flag	
5B		Flag		00
5C		Flag		00
5D		Data Type Tag (ASCII String)		0F
5E		Flag		00
5F		(Horizontal active pixel / 8) - 31	"1368"	8C
60		Image Aspect Ratio	"16 : 9"	09
61		Middle Refresh Rate	"50Hz"	32
62		(Horizontal active pixel / 8) - 31	"1368"	8C
63		Image Aspect Ratio	"16 : 9"	09
64		Low Refresh Rate	"40Hz"	28
65		Brightness (1/10nit)		16
66		Feature flag " TN, White LED Backlight "		09
67		Reserved		00
68		LCD Supplier manufacture Code (3 character ID)	"INL"	25
69	LCD Supplier manufacture Code (3 character ID)		CC	
6A	LCD Supplier Product code		00	
6B	LCD Supplier Product code		00	



SPEC NO. BT140GW04 V.2

PAGE

29/25

Timing Descriptor #4	6C	Flag	00
	6D	Flag	00
	6E	Flag	00
	6F	Data Type Tag (Monitor Name, stored as ASCII)	FE
	70	Flag	00
	71	Model Name, stored as ASCII "B"	42
	72	Model Name, stored as ASCII "T"	54
	73	Model Name, stored as ASCII "1"	31
	74	Model Name, stored as ASCII "4"	34
	75	Model Name, stored as ASCII "0"	30
	76	Model Name, stored as ASCII "G"	47
	77	Model Name, stored as ASCII "W"	57
	78	Model Name, stored as ASCII "0"	30
	79	Model Name, stored as ASCII "3"	33
	7A	Model Name, stored as ASCII "V"	56
	7B	Model Name, stored as ASCII "2"	30
7C	Model Name, stored as ASCII	0A	
7D	Model Name, stored as ASCII	20	
Checksum	7E	Extension flag (# of optional 128 panel ID extension block to follow, Typ = 0)	00
	7F	Check Sum (The 1-byte sum of all 128 bytes in this panel ID block shall = 0)	5E

12. LCD Module Inspection Specifications

12.1 Description

These inspection standards shall be applied to LCD Module supplied by CHI MEI Optoelectronics Corporation.

12.2 The environmental condition of inspection

The environmental condition and visual inspection shall be conducted as below.

- (1) Ambient temperature : 15~25°C
- (2) Humidity: 25~75 %RH
- (3) External appearance inspection shall be conducted by using a single 20W fluorescent lamp or equivalent illumination.
- (4) Panel visual inspection on the operation condition for cosmetic shall be conducted at the distance 30cm between the LCD module and eyes of inspector.

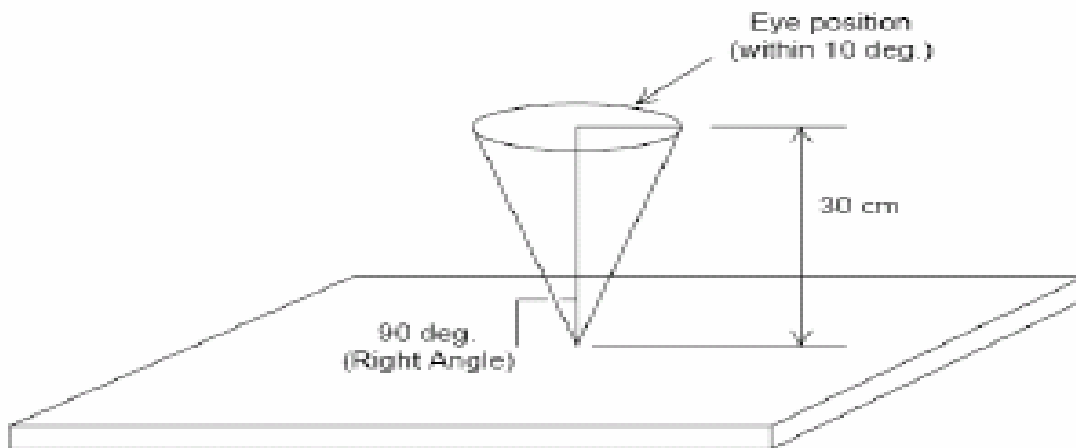

(5) Using method for ND Filter

When using ND Filter for judging Mura, placing ND Filter near Mura defect and get close to the surface of LCD Panel (its distance shall be 1~2cm between the surface of Panel and ND Filter). Don't touch the surface of polarizer to avoid scratching polarizer, and then move to the defect position to judge mura by view angel 90 degree (The viewing angle shall be 90 degree to the right top of Mura defect with panel)

12.3 Classification of defects

Defects are classified two types, major defect and minor defect according to the defect. And, the definition of defects is classified as below.

(1) Major defect

Any defect may result in functional failure, or reduce the usability of product for its purpose. For example, electrical failure, deformation and etc..

(2) Minor defect

A defect that is not to reduce the usability of product for its intended purpose and un-uniformity, dot defect and etc..

The criteria on major and/or minor judgement will be according with the classification of defects.

12.4 Inspection Criteria

(1) Definition of dot defect

Define spec for 2 dot adjacent and minimum distance

2-adjacent(Linked Pixels)

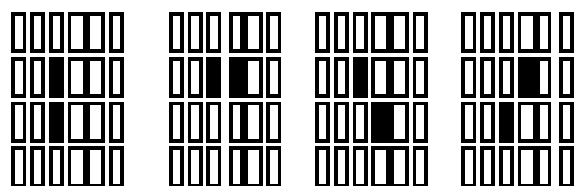

□ : sub-Pixel(R,G,B)

Minimum Distance;

Lit to Lit : $L \geq 15\text{mm}$

Unit to Unit : $L \geq 5\text{mm}$

Lit to Unit : Not Applicable

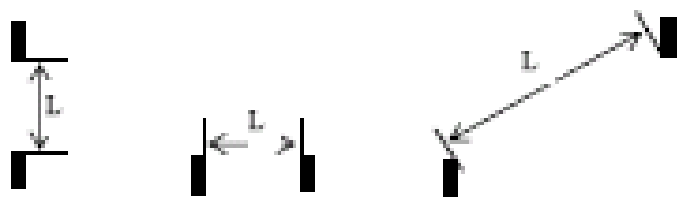

L:Sub-Pixel to Sub-Pixel,Sub-Pixel to 2-adjacent or 2-adjacent to 2-adjacent

(2) Display Inspection

- a) Ambient Illumination: 250 lux or more for light on inspection
- b) Viewing Angle: Within LCD Viewing Angle Specification
- c) Inspection Pattern (Bright dot): In black pattern
Inspection Pattern (Dark dot): In red, green, blue pattern

Items		XGA WXGA	SXGA+ WXGA+ WSXGA+	UXGA WUXGA	HD HD+ FHD
Bright dot	Random	$N \leq 2$	$N \leq 2(G=1)$	$N \leq 2(G=0)$	$N \leq 2(G=0)$
	2 dots adjacent	$N \leq 1(G=0)$	$N \leq 0$	$N \leq 0$	$N \leq 0$
	3 dots adjacent or more	$N \leq 0$	$N \leq 0$	$N \leq 0$	$N \leq 0$
Dark dot	Random	$N \leq 3$	$N \leq 5$	$N \leq 10$	$N \leq 3$
	2 dots adjacent	$N \leq 1$	$N \leq 1$	$N \leq 2$	$N \leq 1$
	3 dots adjacent or more	$N \leq 0$	$N \leq 0$	$N \leq 0$	$N \leq 0$
Distance	Lit to Lit	$L \geq 15\text{mm}$	$L \geq 15\text{mm}$	$L \geq 15\text{mm}$	$L \geq 15\text{mm}$
	Unlit to Unlit	$L \geq 5\text{mm}$	$L \geq 5\text{mm}$	$L \geq 5\text{mm}$	$L \geq 5\text{mm}$
	Lit to Unlit	Not allowable	Not allowable	Not allowable	Not allowable
Total bright and dark dot		$N \leq 5$	$N \leq 7$ (SXGA+ WXGA+) $N \leq 9$ (WSXGA+)	$N \leq 10$ (UXGA) $N \leq 12$ (WUXGA)	$N \leq 5$
Defective Dot (Lit/Unlit) : Noticeable defective dots in the office environment (250 lux) will be counted regardless of defective dot size					
Display failure (V-line/H-line/Cross line etc.)				Not allowable	
Mura	Mura defect can not show in 50% gray pattern with 8% ND-filter or judge by limit sample if necessary				

(3) Appearance Inspection

- a) Ambient Illumination: 500 ~ 700 Lux
- b) Viewing Angle: Backlight-Off Condition: At Right Angle To Polarizer Surface
Backlight-On Condition: Within LCD Viewing Angle Specification
- c) Inspection Pattern: In White and 32-Gray(Half-Gray)Screens(Backlight-On)

Items	Size(mm)	Acceptable count
1. Scratch(Line Shape) : B/L -off condition	$W \leq 0.05$	Ignore
	$0.05 \leq W < 0.1; 0.3 \leq L \leq 3.0$	$N \leq 4$
	$0.10 \leq W$ or $3.0 < L$	$N = 0$
	Shall be no visible at B/L on.	
2. Dent : B/L -off condition	$D < 0.2$	Ignore
	$0.2 \leq D < 0.5$	$N \leq 5$
	$0.5 \leq D$	$N = 0$
	Spacing between defects shall be more than 30 mm. ($0.2 \leq D < 0.5$) Shall be no visible at B/L on.	
3. Bubble : B/L -off condition	$D < 0.2$	Ignore
	$0.2 \leq D < 0.5$	$N \leq 5$
	$0.5 \leq D$	$N = 0$
	Shall be no visible at B/L on.	
4. Foreign material (Line-shape: stain inclusion) : B/L-on condition	$W \leq 0.05$	Ignore
	$0.05 \leq W < 0.10; 0.3 \leq L \leq 2.0$	$N \leq 4$
	$0.10 \leq W$ or $2.0 < L$	$N = 0$
	Shall be no visible at B/L on.	
5. Foreign material (Dot-shape: stain inclusion) : B/L-on condition	$D < 0.2$	Ignore
	$0.2 \leq D < 0.5$	$N \leq 5$
	$0.5 \leq D$	$N = 0$
	Shall be no visible at B/L on.	
6. Peeling on Polizer edge : B/L-off condition	$D < 0.2$	Ignore
	$0.2 \leq D < 0.5$	$N \leq 5$
	$0.5 \leq D$	$N = 0$
	Bubble or glue shall not be visible within PC bezel opening area with specified inspection viewing angle. Continuous peeling off on polarizer edge shall be discussed. Shall be no visible at B/L on.	



$$D = (a+b)/2$$



W: width, L: length

SPEC NO. BT140GW04 V.2

PAGE 34/25

12.5 External Appearance Inspection Criteria

Item	Contents	
Screw	Parts mounting, incomplete assembly, deformation, oxidized, crooked or rusty is not permitted.	
CCFT cable	Cable not continuous / Break-off / Connector Burn-off / Break-off	
Metal frame (Bezel)	Scratch	*Noticeable scratch and exfoliation coating are not permitted. *The oxidized metal is not permitted.
	Incomplete assembly is not permitted.	
Backlight	Scratch	The scratch which may causes a problem in practical use is not permitted.
	Break-off	Breaking off is not permitted.
	Crack	The crack is not permitted.
Stain on Polarizer	The stain which can't be wiped off is not permitted.	
Tape/Label	Incorrect position, missed label is not permitted.	
Connector	Oxidized/rusty connector is not permitted.	
Outline size	Spec. out is not permitted.	

12.6 Classification of defects

Inspection Item	Criteria and Description	Defect type
Vertical line	Signal input, vertical line off or irregular V-line appears	major
Horizontal line	Signal input, horizontal line off or irregular H-line appears	major
Cross line	Pattern signal input, a correct display is not obtained	major
No display	Signal input, display is dead	major
Irregular display	Pattern signal input, a correct display is not obtained	major
Dots defect	Exceed specified standards	minor
Scratch and Dent on polarizer	Exceed specified standards	minor
Foreign material	Exceed specified standards	minor
Mura	Mura defect can not show in 50% gray pattern with 8% ND-filter or judge by limit sample if necessary	minor
External Appearance	Rust, deformation, irregular plating, coating missing etc. A appearance defect that do not affect function or performance	minor
Bezel claw	Bezel claw missing or not bent	major
Polarizer bubble	Exceed specified standards	minor
Flicker	No noticeable flicker by naked eyes at any gray scale level	major
LCD Pooling	In 50% gray pattern, hold LCD panel TOP edge (PCB side) by both hands and swing slightly back and forth 2 times per second for 3 cycles by 15 degrees (Range 30 degrees)	minor