

# **INNOLUX** DISPLAY CORPORATION

## **BT141XG01 LCD MODULE SPECIFICATION**

---

**Preliminary**

**Version 08**

Customer	Checked & Approved by

Approved by	Checked by		Prepared by
MKT	QRA	PD	MKT

Date: \_\_\_\_\_

**Innolux Display Corporation,**

No.160 Kesyue Rd., Chu-Nan Site, Hsinchu Science Park,

Chu-Nan 350 , Miao-Li County, Taiwan

Tel: 886-37-586000

Fax: 886-37-586060

Document Number: BT141XG01 -Q03

<http://www.BDTIC.com/INNOLUX>

## Record of Revision

Version	Revise Date	Page	Content
01	2004-06-04		First edition to all
02	2004-07-14	7	LVDS Macro AC characteristics
		7	AC Timing Diagram
		9	Timing characteristics of input signals
		15	Reliability test items
03	2004-07-15	12	Add optical specification measurement method
		15	Remove reliability test item (2) Shock & Vibration
04	2004-09-09		Revise format
		17	Add Module Label description
		18	Add Product Number
05	2004-10-15	5	Update connector
		6	Update CCFL Current. Add CCFL Voltage
		10	Update backlight driving conditions- Lamp voltage, Lamp current, power consumption, Lamp stating voltage, Frequency. Add Burst mode, Duty cycle
		12	Update Clolor chormaticity R, G, B
		20	Update cable length
06	2004-12-01	7	Add CCFL voltage, Re-screw, Assured Torque at Side Mount
		8	Add Power consumption, Rush current
		11	Update Lamp voltage from 725 to 705 (max), Power consumption from 4.72 to 4.58 (max), Add Bust mode, Duty cycle
		13	Add view angle 15/35/45/45 (U/D/L/R) (Typ.)
		15	Update note 8 graph from 1/10 to 10mm

		16	Update Electrostatic discharge from 150 pF,330Ω, Contact: ±8kV,Air: ±15kV (operation) Contact: ±10kV,Air: ±20kV (non-operation) to 150 pF,330Ω, Contact: ±8kV,Air: ±15kV (non-operation)
		20	Add packing form
07	2004-12-07	8	Add mosaic pattern explanation. Update power consumption pattern from mosaic pattern to all black pattern.
		12	Add panel power sequence
		21	Update front view drawing (from 15.52 to 15)
		22	Update back view drawing (from 70.75 to 70.82)
		16	Update reliability from 300Hrs to 240Hrs Update random vibration from 2Hrs to 1Hr Update mechanical shock from 3 times to one time Update Electrostatic discharge from non-operation to operation Update Temperature cycling to Thermal Shock Add humidity test to high tempetaure storage and operation
		7	Add environment range for operation and storage drawing
08	2005-01-17	8	Add CCFL current min. value
		9,10,11	Add Note 3 for rush current Add Note 4 for power sequence
		14,15	Add Note 2,3,4 for lamp starting voltage Revise power consumption min. from 1.72 to “-“, max.from 4.58 to 4.4 Revise starting voltage from 1200 to 1300 at 25°C
		16	Add respond time max. value Add color chromaticity (CIE) min. and max. value

		19	Revise mechanical shock from 240G/2ms to 220G/2ms
		22	Add carton lable description
		23	Revise packing form

INNOLUX

Confidential

<b>Contents:</b>	
<b>A. General Specification</b>	
<b>B. Electrical Specifications</b>	
1. Pin assignment	
2. Absolute maximum ratings	
3. Electrical characteristics	
a. Typical operating conditions	
b. Display color v.s. input data signals	
c. Input signal timing	
d. Display position	
e. Backlight driving conditions	
<b>C. Optical specifications</b>	
<b>D. Reliability test items</b>	
<b>E. Safety</b>	
<b>F. Display quality</b>	
<b>G. Handling precaution</b>	
<b>H. Label</b>	
<b>I. Packing form</b>	
<b>J. Mechanical drawings</b>	
<b>Appendix</b>	

**A. General specification**

NO.	Item	Specification	Remark
1	Display resolution (pixel)	1024(H) X 768(V), XGA resolution	
2	Active area (mm)	285.7(H) X 214.3(V)	
3	Screen size (inch)	14.1 inches diagonal	
4	Pixel pitch (mm)	0.279(H) X 0.279(V)	
5	Color configuration	R, G, B vertical stripe	
6	Overall dimension (mm)	299(W) X 228(H) X 5.2(D) Typ.	
7	Weight (g)	410 Typ. (w/o Inverter)	
8	Surface treatment	Anti-glare, Haze = 25%, Hard coating (3H)	
9	Input color signal	6 bit LVDS	
10	Color saturation	45% NTSC	
11	Display colors	262K (6 bit)	
12	Optimum viewing direction	6 o'clock	
13	Backlight	1 CCFL	

**B. Electrical specifications**

## 1.Pin assignment

**Connector** FI-XB30SL-HF10 or compatible

Pin No	Symbol	Description
1	GND	Ground
2	VDD	+3.3V power supply
3	VDD	+3.3V power supply
4	V <sub>EDID</sub>	+3.3V EDID power
5	NC	
6	CLK <sub>EDID</sub>	EDID clock input
7	DATA <sub>EDID</sub>	EDID data input
8	RxIN0-	LVDS differential data input (Red0-Red5, Green0)
9	RxIN0+	LVDS differential data input (Red0-Red5, Green0)
10	GND	Ground
11	RxIN1-	LVDS differential data input (Green1-Green5, Blue0-Blue1)
12	RxIN1+	LVDS differential data input (Green1-Green5, Blue0-Blue1)
13	GND	Ground
14	RxIN2-	LVDS differential data input (Blue2-Blue5, Hsync, Vsync, DSPTMG)
15	RxIN2+	LVDS differential data input (Blue2-Blue5, Hsync, Vsync, DSPTMG)
16	GND	Ground
17	RxCLKIN-	LVDS differential clock input
18	RxCLKIN+	LVDS differential clock input
19	GND	Ground
20~30	NC	



2. Absolute maximum ratings

Parameter	Symbol	Values		Unit	Remark
		Min.	Max.		
Power voltage	$V_{DD}$	- 0.3	4.0	V	At 25°C
Input signal voltage	$V_{LH}$	- 0.3	4.3	V	At 25°C
Operating temperature	$T_{op}$	0	50	°C	Note 1
Storage temperature	$T_{ST}$	- 20	60	°C	Note 2
CCFL Current	ICFL	2	6.5	[mA] rms	
CCFL Voltage		-	2.5	KV	
Re-screw		-	5	Times	
Assured Torque at Side Mount		-	2.5	[kgf.cm]	

Note 1: The relative humidity must not exceed 90% non-condensing at temperatures of 40°C or less. At temperatures greater than 40°C, the wet bulb temperature must not exceed 39°C.

Note 2: The unit should not be exposed to corrosive chemicals.

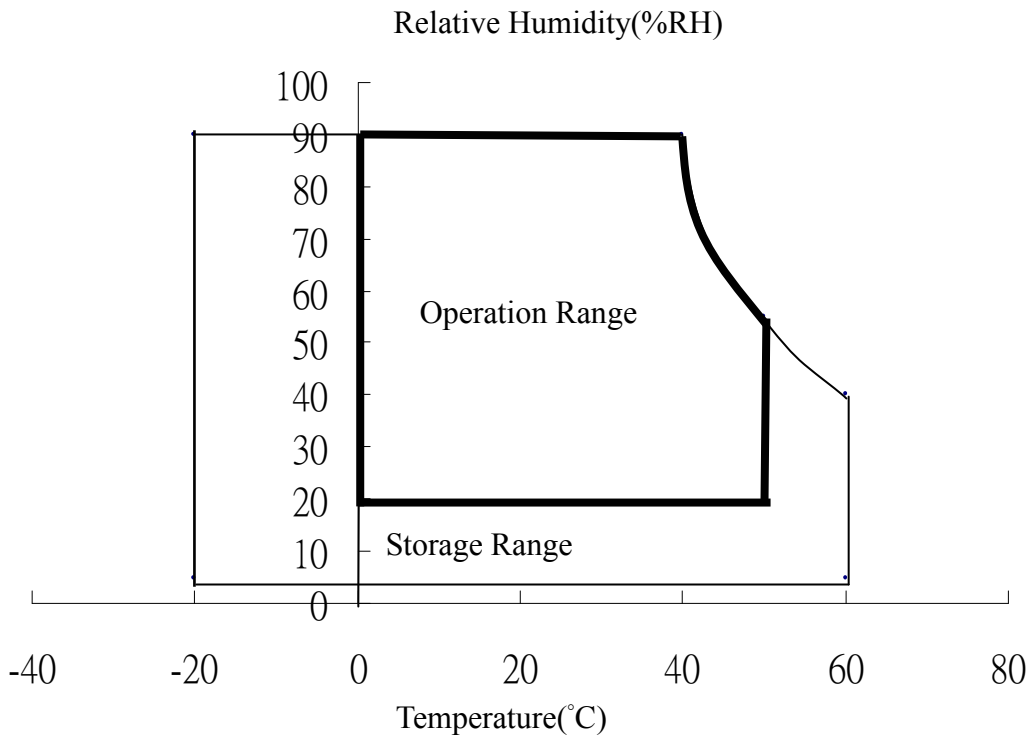



## 3. Electrical characteristics

## a. Typical operating conditions

Item	Symbol	Min.	Typ.	Max.	Unit	Remark
Input voltage	$V_{DD}$	3	3.3	3.6	V	
Permissive Power Input Ripple	$V_{RF}$	-	-	0.1	V	
Input Current	$I_{DD}$	-	0.35	0.45	A	Note 1
Power Consumption	$P_C$	-	1.4	1.65	Watts	Note 2
Rush Current	$I_{Rush}$	-	-	1.5	A	Note 3

Note 1: The specified input current is under the  $V_{cc} = 3.3\text{ V}$ ,  $25\text{ }^\circ\text{C}$ ,  $fV=60\text{Hz}$  (frame frequency) condition whereas mosaic pattern (black & white [5\*5] ) is displayed.

White : 63 Gray

Black : 0Gray

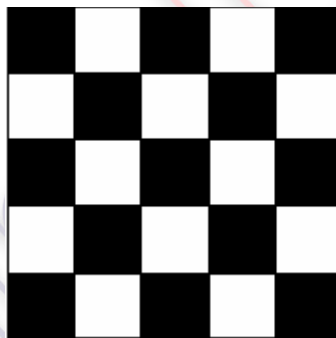

mosaic pattern (black & white [5\*5] )

Note 2 : The specified power consumption is under the  $V_{cc} = 3.3\text{ V}$ ,  $25\text{ }^\circ\text{C}$ ,  $fV=60\text{Hz}$  (frame frequency) condition whereas all black pattern is displayed.

Note 3 : test condition :

- (1)  $V_{DD} = 3.3\text{ V}$ ,  $V_{DD}$  rising time =  $470\ \mu\text{s} \pm 10\%$
- (2) Pattern: Mosaic pattern

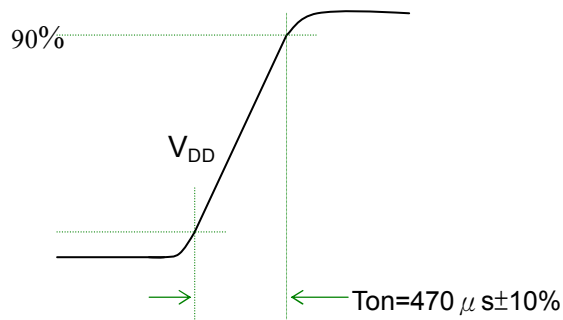

(3) Test circuit

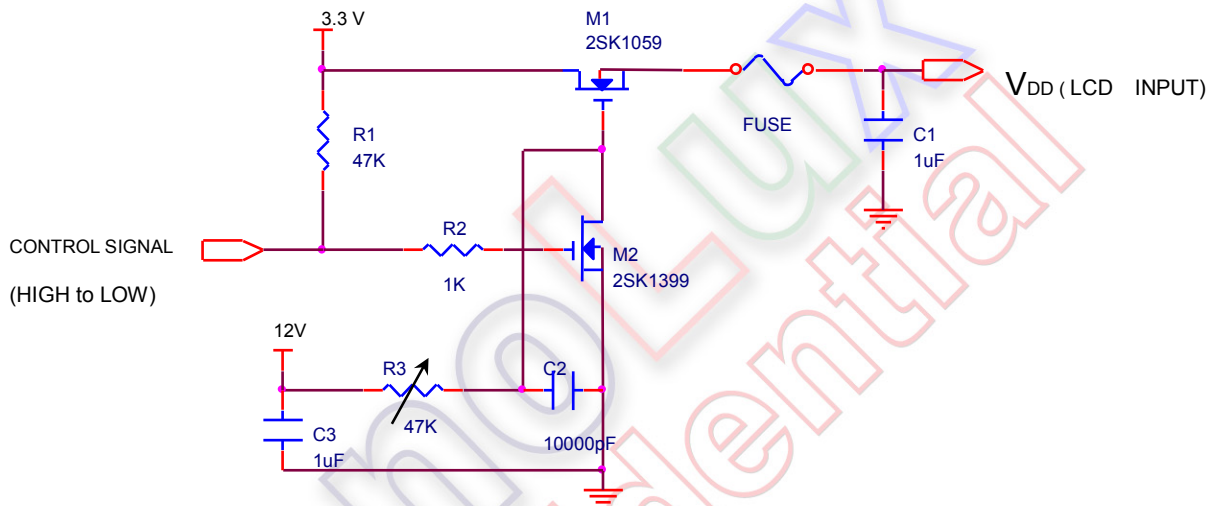

Note 4 : Power on sequence for LCD  $V_{DD}$

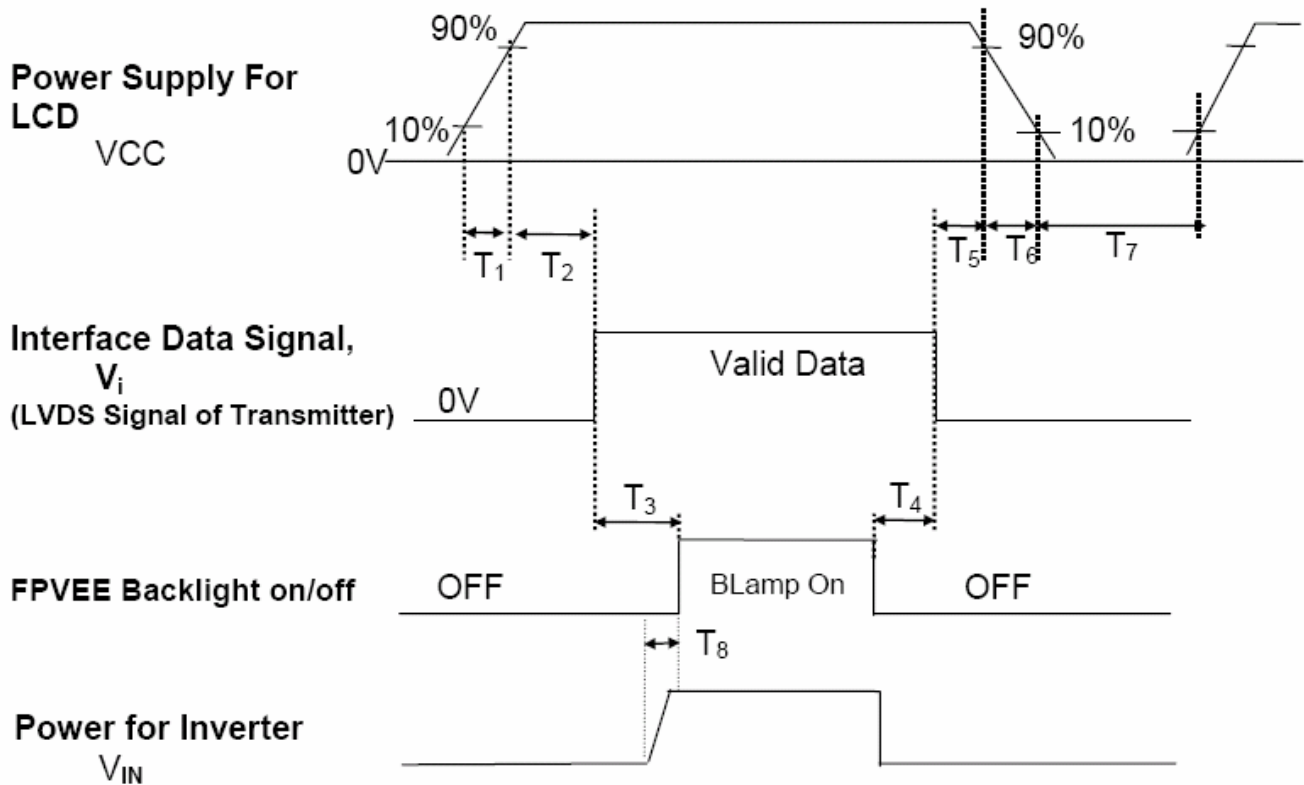

**Power Sequence Timing**

Parameter	Value			Units
	Min.	Typ.	Max.	
T1	0.5	-	10	(ms)
T2	0	-	50	(ms)
T3	200	-	-	(ms)
T4	200	-	-	(ms)
T5	0	-	50	(ms)
T6	0	-	10	(ms)
T7	200	-	-	(ms)
T8	10	-	-	(ms)

## b. Display color v.s. input data signals

Signal Name	Description	Remark
+RED5	Red Data 5 (MSB)	Red-pixel data. Each red pixel's brightness data consists of these 6 bits pixel data.
+RED4	Red Data 4	
+RED3	Red Data 3	
+RED2	Red Data 2	
+RED1	Red Data 1	
+RED0	Red Data 0 (LSB)	
	<b>Red-pixel Data</b>	
+GREEN 5	Green Data 5 (MSB)	Green-pixel data. Each green pixel's brightness data consists of these 6 bits pixel data.
+GREEN 4	Green Data 4	
+GREEN 3	Green Data 3	
+GREEN 2	Green Data 2	
+GREEN 1	Green Data 1	
+GREEN 0	Green Data 0 (LSB)	
	<b>Green-pixel Data</b>	
+BLUE 5	Blue Data 5 (MSB)	Blue-pixel data. Each blue pixel's brightness data consists of these 6 bits pixel data.
+BLUE 4	Blue Data 4	
+BLUE 3	Blue Data 3	
+BLUE 2	Blue Data 2	
+BLUE 1	Blue Data 1	
+BLUE 0	Blue Data 0 (LSB)	
	<b>Blue-pixel Data</b>	
-DTCLK	<b>Data Clock</b>	The typical frequency is 65.0 MHz. The signal is used to strobe the pixel data and DSPTMG signals. All pixel data shall be valid at the falling edge when the DSPTMG signal is high.
DSPTMG	<b>Display Timing</b>	This signal is strobed at the falling edge of -DTCLK. When the signal is high, the pixel data shall be valid to be displayed.
VSYNC	<b>Vertical Sync</b>	The signal is synchronized to -DTCLK .
HSYNC	<b>Horizontal Sync</b>	The signal is synchronized to -DTCLK.

c. Input signal timing

Support Input Timing Table

Description	Symbol	Min	Typ	Max	Unit
DTCLK frequency	fdck		65		[MHz]
DTCLK cycle time	tck		15.38		[nsec]
X total time	tx	1320	1344	2047	[tck]
X active time	tacx		1024		[tck]
H frequency	Hsync		48.363		[KHz]
H-Sync width	Hsw		136		[tck]
H back porch	Hbp		160		[tck]
H front porch	Hfp		24		[tck]
Y total time	ty	803	806	2047	[tx]
Y active time	tacy		768		[tx]
Frame rate	Vsync		60		[Hz]
V-sync Width	Vw		6		[tx]
V-sync front porch	Vfp		3		[tx]
V-sync back porch	Vbp		29		[tx]

**Note:** Hsw(H-sync width) + Hbp(H-sync back porch) should be less than 515 tck.

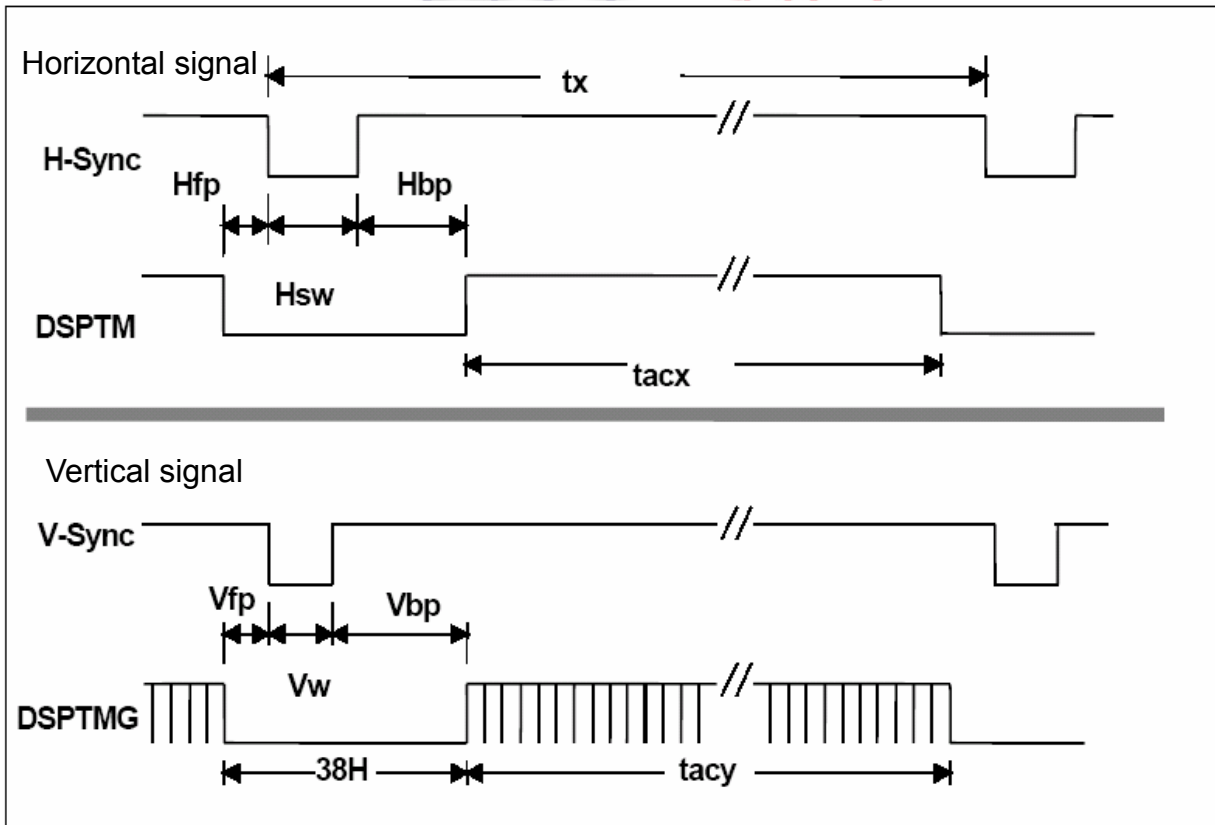

d. Display Position

D(1, 1)	D(2, 1)	.....	D(512, 1)	.....	D(1023, 1)	D(1024, 1)
D(1, 2)	D(2, 2)	.....	D(512, 2)	.....	D(1023, 2)	D(1024, 2)
⋮		.....	⋮	.....	⋮	⋮
D(1, 384)	D(2, 384)	.....	D(512, 384)	.....	D(1023, 384)	D(1024, 384)
⋮		.....	⋮	.....	⋮	⋮
D(1, 767)	D(2, 767)	.....	D(512, 767)	.....	D(1023, 767)	D(1024, 767)
D(1, 768)	D(2, 768)	.....	D(512, 768)	.....	D(1023, 768)	D(1024, 768)

e. Backlight driving conditions

Parameter	Symbol	Min.	Typ.	Max.	Unit	Remark	Remark
Lamp voltage	VL	575	640	705	Vrms		
Lamp operation current	IL	2	6	6.5	mArms		Note 1
Power consumption	PL	-	3.84	4.4	W		
Lamp starting voltage	VLstart	1300			Vrms	T = 25°C	Note 2,3,4
		1500				T = 0°C	Note 2,3,4
Frequency	F	50	60	80	KHZ		Note 4
Lamp life time		10,000			Hr		Note 5
Burst Mode		155	160	165	HZ		
Duty Cycle		30%		100%			

Note 1 :

The degrees of unbalance: less than 10%

The ratio of wave height: less than  $\sqrt{2} \pm 10\%$

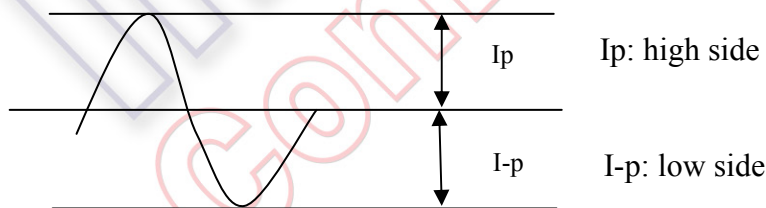

The degrees of unbalance =  $|Ip - I-p| / Irms * 100(\%)$

The ratio of wave height =  $Ip(\text{or } I-p) / Irms$

Lamp should be completely turned on.

Note 2:

The voltage shown above should be applied to the lamp for more than 1 second after startup.

Otherwise, the lamp may not be turned on normally.

## Note 3:

Inverter should provide more than min. value, and then lamp could be completely turned on

## Note 4:

Lamp frequency may produce interference with horizontal synchronous frequency and this may cause line flow on the display. Therefore lamp frequency shall be detached from the horizontal synchronous frequency and its harmonics as far as possible in order to avoid interference.

## Note 5:

Lamp life definition :

(A) Lamp current  $I_L = (6) \text{ mA}$

(B) The brightness of lamp becomes 50% of the initial brightness or not normal lighting.

Backlight connector : JST BHSR-02VS-1

Pin no.	Symbol	Function	Remark
1	VIH	Lamp high voltage input	Cable color: Pink
2	VIL	Lamp low voltage input	Cable color: White



**C. Optical specifications**

Item	Symbol	Condition	Specification			Unit	Remark
			Min.	Typ.	Max.		
Response time	Tr+Tf	$\theta = 0^\circ$		25	35	ms	Note 4
Contrast ratio	CR	$\theta = 0^\circ$	250	300			Note 3,5
Viewing angle	Top	$CR \geq 10$	10	15		deg	Note 3,5,7
	Bottom	$CR \geq 10$	30	35			
	Left	$CR \geq 10$	40	45			
	Right	$CR \geq 10$	40	45			
Brightness (5 points)	$Y_l$		170	200		nit	Note 3,6
Color chromaticity(CIE)	$W_x$	$\theta = 0^\circ$	-0.03	0.313	+0.03		Note 3
	$W_y$			0.329			
	$R_x$			0.569			
	$R_y$			0.332			
	$G_x$			0.312			
	$G_y$			0.544			
	$B_x$			0.149			
	$B_y$			0.132			
White uniformity (13)	$\delta_w$		0.67				Note 3,8
Cross talk	Ct				1.3%		Note 9

Note 1: Ambient temperature = 25°C.

Note 2: To be measured in dark room after backlight warm up 30 minutes.

Note 3: To be measured with a viewing cone of 2° by Topcon luminance meter BM-5A.

Note 4: Definition of response time:

The output signals of BM-7 are measured when the input signals are changed from “Black” to “White” (falling time) and from “White” to “Black” (rising time), respectively. The response time interval between the 10% and 90% of amplitudes. Refer to figure as below.

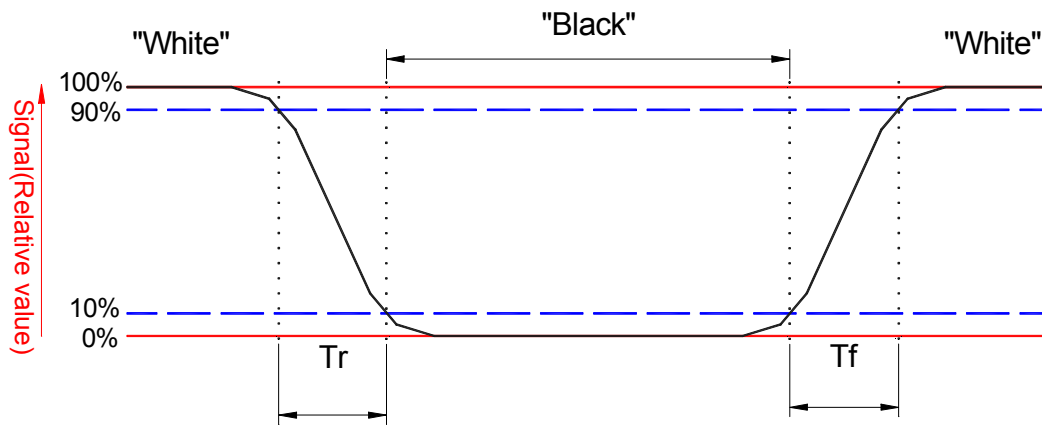

Note 5. Definition of contrast ratio:

Contrast ratio is calculated with the following formula.

$$\text{Contrast ratio (CR)} = \frac{\text{Brightness on the "white" state}}{\text{Brightness on the "black" state}}$$

Note 6: Driving conditions for CCFL:  $I_L = 6.0 \text{ mA}$ , 62 KHz Frequency.

Luminance are measured at the following thirteen points (1~13).

$Y_L = \text{Point 5, 10, 11, 12, and 13 brightness average}$

Note 7: Definition of viewing angle

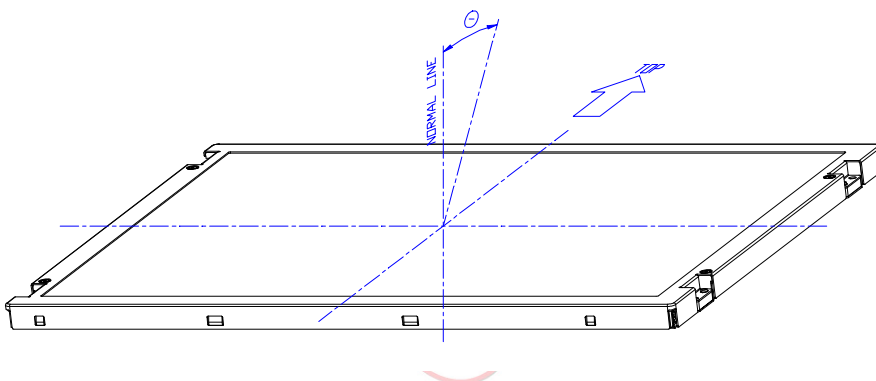

Note 8: Definition white uniformity:

Luminance are measured at the following thirteen points (1~13).

$$\delta_w = \frac{\text{Minimum Brightness of thirteen points}}{\text{Maximum Brightness of thirteen points}}$$

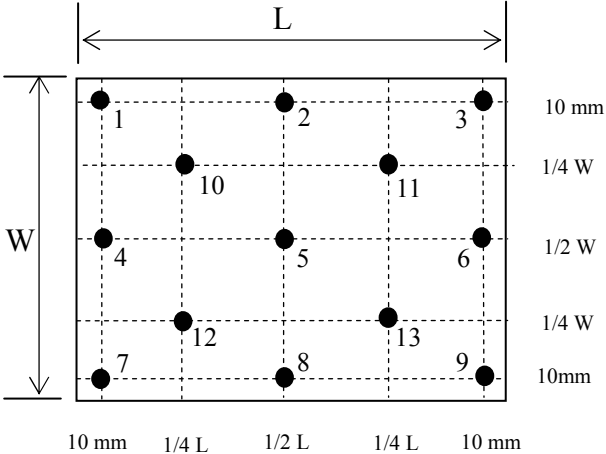

Note 9:

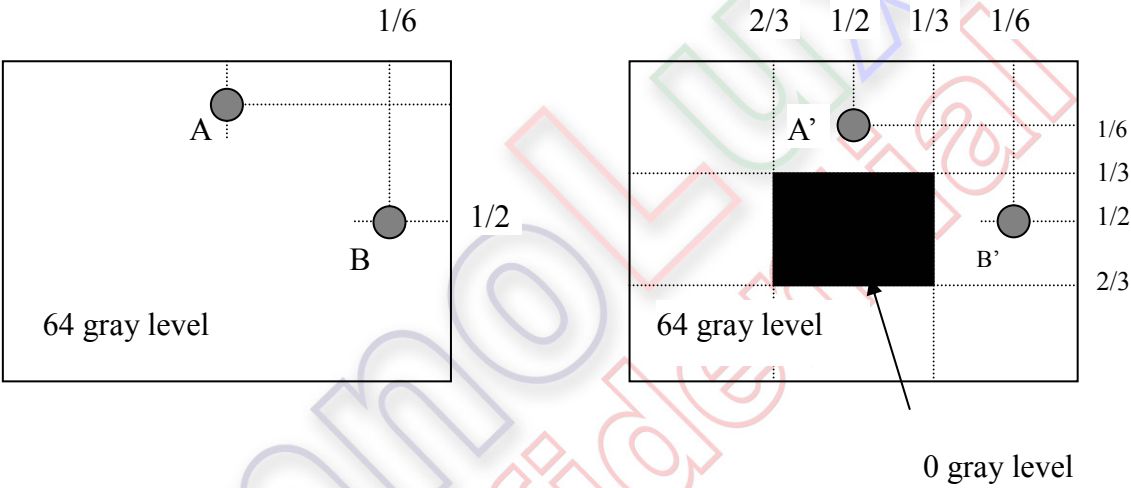

Unit: percentage of dimension of display area

$|L_A - L_{A'}| / L_A \times 100\% = 2\% \text{ max.}$ ,  $L_A$  and  $L_{A'}$  are brightness at location A and A'  
 $|L_B - L_{B'}| / L_B \times 100\% = 2\% \text{ max.}$ ,  $L_B$  and  $L_{B'}$  are brightness at location B and B'

**D. Reliability test items**

Test Item	Test Condition	Judgement	Remark
High temperature storage	60°C, 40%RH ,240Hrs	Note 1	Note 2
Low temperature storage	-20°C, 240Hrs	Note 1	Note 2
High temperature & high humidity operation	40°C, 90%RH,240Hrs (No condensation)	Note 1	Note 2
High temperature operation	50°C, 40%RH, 240Hrs	Note 1	Note 2
Low temperature operation	0°C, 240Hrs	Note 1	Note 2
Thermal Shock (non-operation)	-20°C~60°C 1Hr, 10mins, 1Hr, 100cycles	Note 1	Note 2
Electrostatic discharge (ESD)	150 pF,330Ω, Contact: ±8kV,Air: ±15kV (operation)	Note 1	
Vibration (Sine Wave) (non-operation)	Sinusoidal vibration, 1.5G zero-to-peak, 10 to 500 Hz, 0.5 octave/minute; 0.5Hr in each perpendicular axes.	Note 1	Note 2
Vibration (Random) (for package) (non-operation)	0.015G <sup>2</sup> /Hz from 5~200Hz\ -6dB/Octave from 200~500Hz 1Hr for each X,Y,Z three axes	Note 1	Note 2
Mechanical shock (non-operation)	220G/2ms, Half Sine wave, ±X, ±Y, ±Z one time for each direction	Note 1	Note 2

**Note 1 :**

Pass: Normal display image with no obvious non-uniformity and no line defect.  
Partial transformation of the module parts should be ignored.

Fail: No display image, obvious non-uniformity, or line defects.

**Note 2 :**

Evaluation should be tested after storage at room temperature for one hour.

## **E. Safety**

### **(1) Sharp Edge Requirements**

There will be no sharp edges or corners on the display assembly that could cause injury.

### **(2) Materials**

#### **a. Toxicity**

There will be no carcinogenic materials used anywhere in the display module. If toxic materials are used, they will be reviewed and approved by the responsible InnoLux Toxicologist.

#### **b. Flammability**

All components including electrical components that do not meet the flammability grade UL94-V1 in the module will complete the flammability rating exception approval process. The printed circuit board will be made from material rated 94-V1 or better. The actual UL flammability rating will be printed on the printed circuit board.

#### **C. Capacitors**

If any polarized capacitors are used in the display assembly, provisions will be made to keep them from being inserted backwards.

## **F. Display quality**

The display quality of the color TFT-LCD module should be in compliance with the InnoLux's Incoming inspection standard.

## **G. Handling precaution**

The Handling of the TFT-LCD should be in compliance with the InnoLux's handling principle standard.

**H. Label**

(1) Module Label

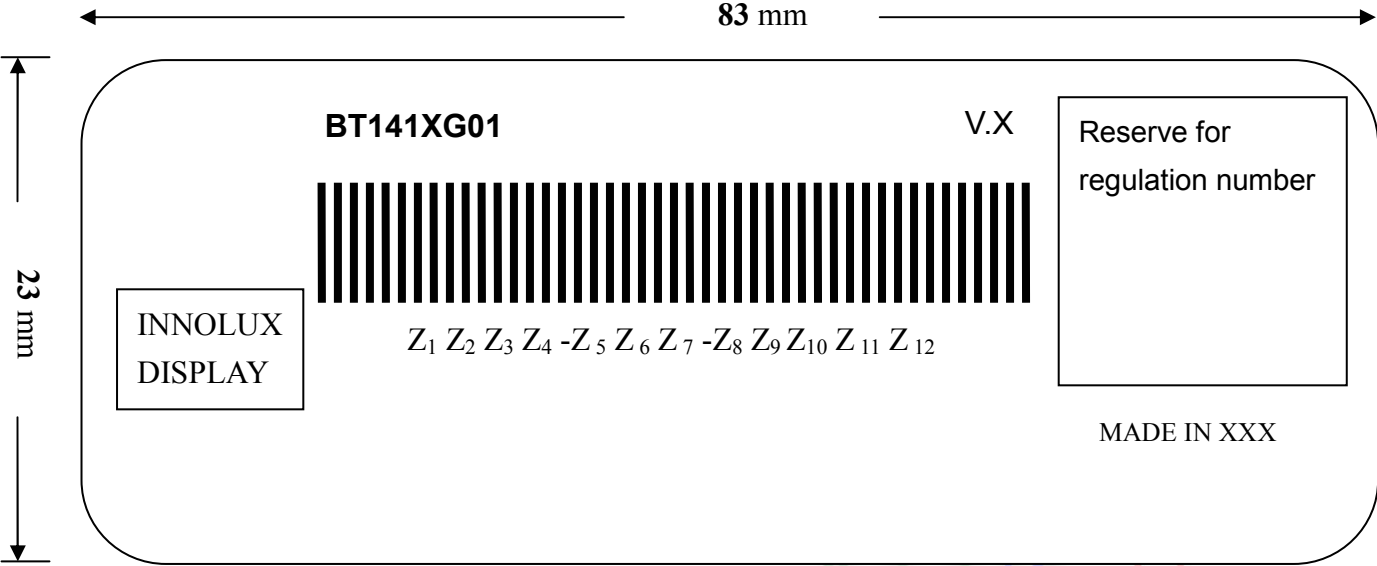

(a) Model name : BT141XG01

(b) Version : V.x, for example 0, 1, 2 etc.

(c) Serial ID : Z<sub>1</sub> Z<sub>2</sub> Z<sub>3</sub> Z<sub>4</sub> Z<sub>5</sub> Z<sub>6</sub> Z<sub>7</sub> Z<sub>8</sub> Z<sub>9</sub> Z<sub>10</sub> Z<sub>11</sub> Z<sub>12</sub>

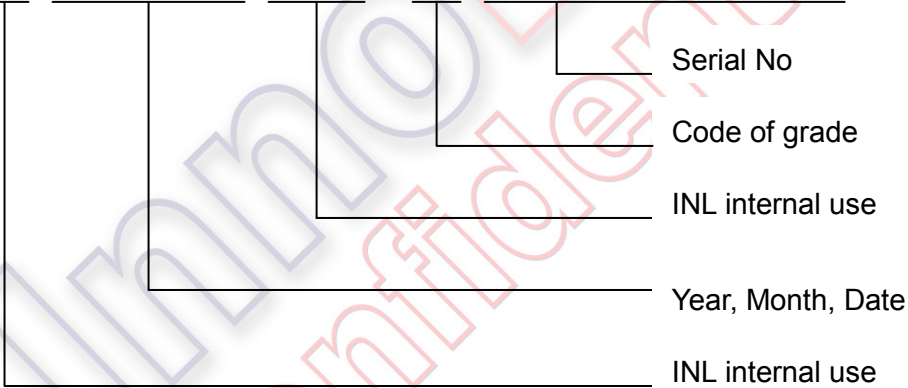

Serial ID includes the information as below :

(a) Manufactured Date: Year: 0~9, for 2000~2009

Month: 1~9 & A~C for Jan.~Dec.

Date: 1~9 & A~Z (exclude I, O, Q, U) for 1th~31th

(b) Code of grade: 0, 1, 3, 5, 7

(c) Serial No: Module manufacture sequential no



(2) Carton Label

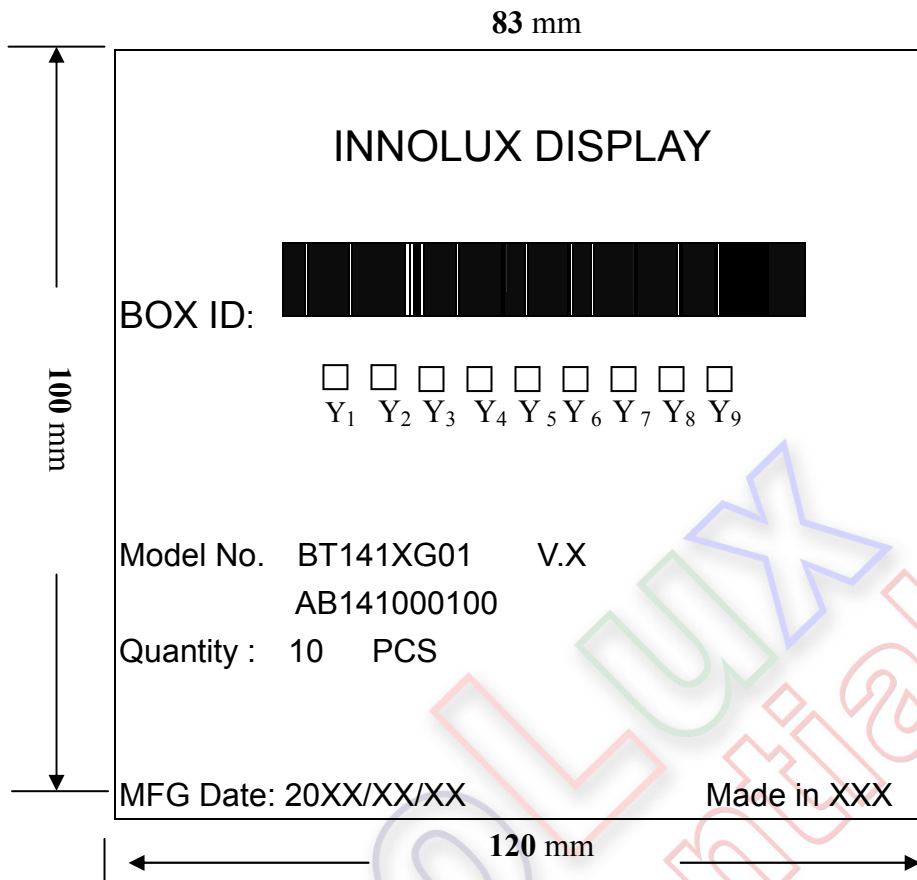

- (a) Model name : BT141XG01
- (b) Version : V.x, for example 0, 1, 2 etc.
- (c) Product number : AB141000100
- (d) Packing quantity : 10 pcs
- (e) Serial ID : Z<sub>1</sub> Z<sub>2</sub> Z<sub>3</sub> Z<sub>4</sub> Z<sub>5</sub> Z<sub>6</sub> Z<sub>7</sub> Z<sub>8</sub> Z<sub>9</sub>

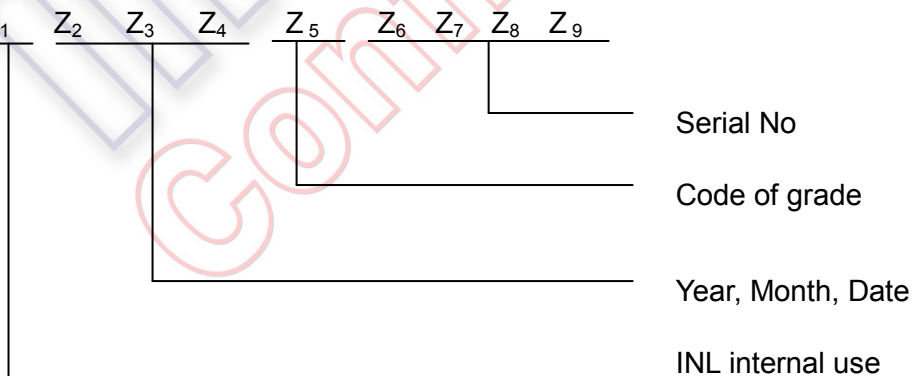

Serial ID includes the information as below :

- (a) Manufactured Date: Year: 0~9, for 2000~2009  
 Month: 1~9 & A~C for Jan.~Dec.  
 Date: 1~9 & A~Z (exclude I, O, Q, U) for 1th~31th
- (b) Code of grade: 0, 1, 3, 5, 7
- (c) Serial No: Module packing sequential no



I. Packing form

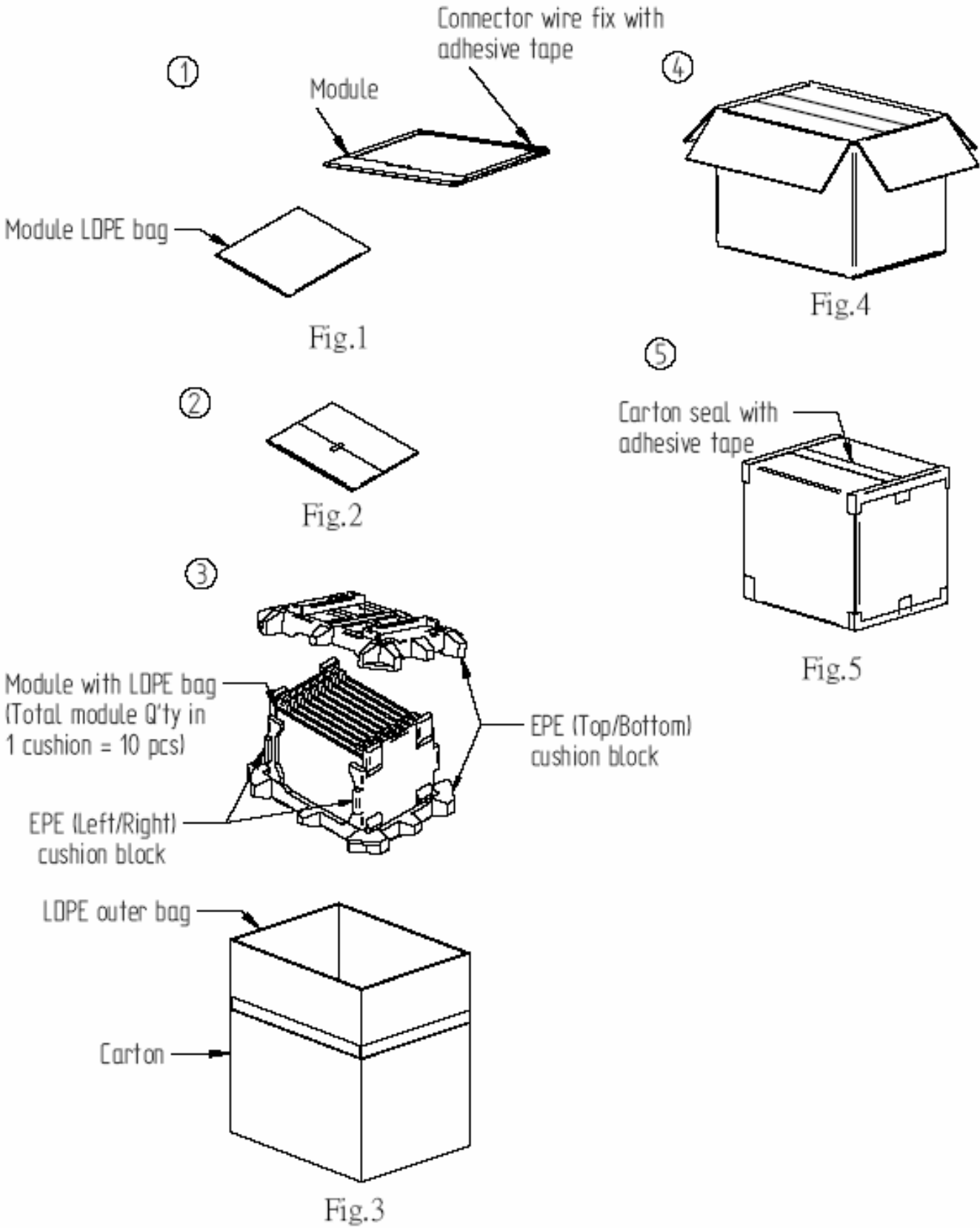

**J. ME Drawing  
(1) Front view**

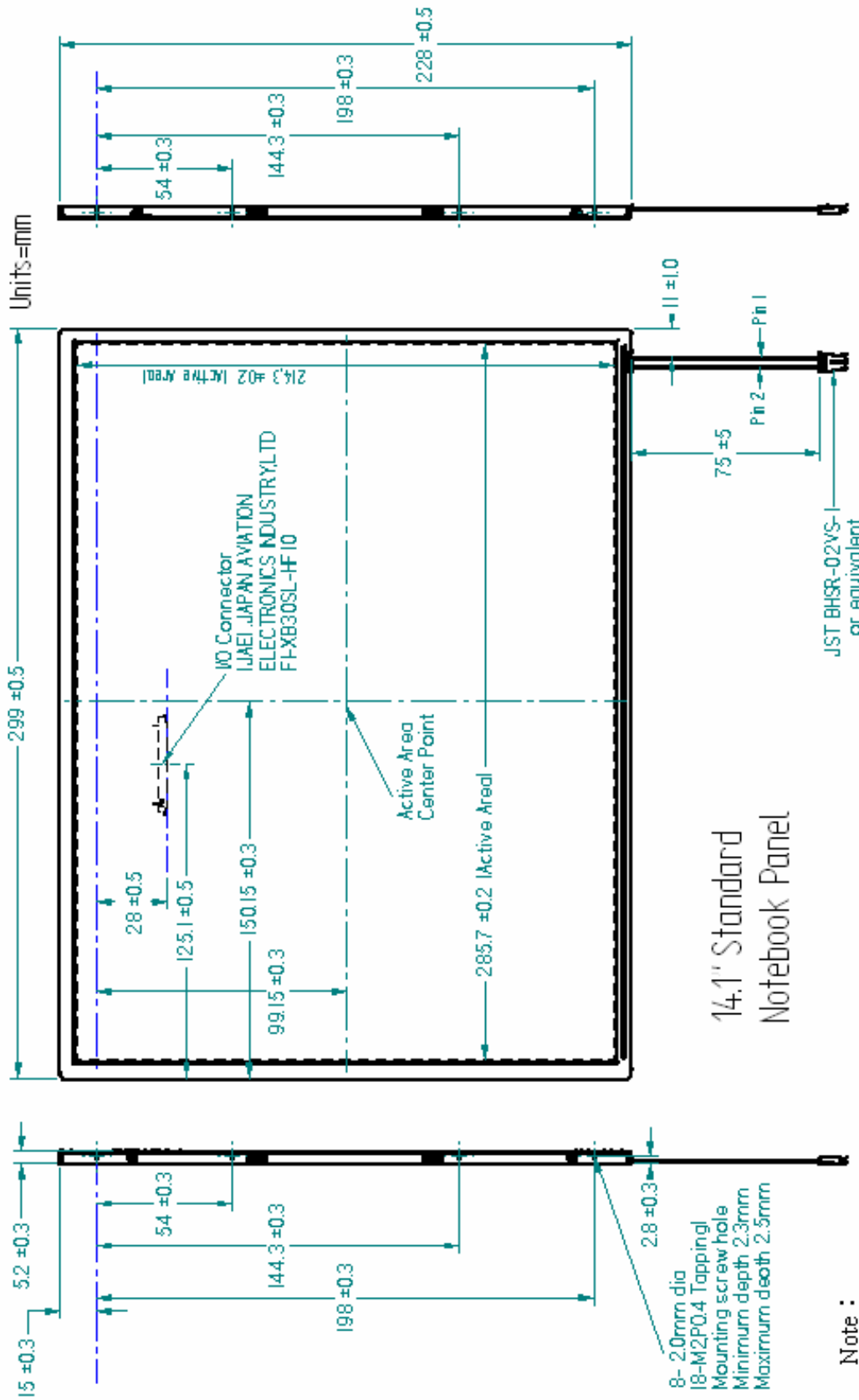

**Note :**

1. Connector Pin 1 is High Voltage Line of Color Pink
2. Connector Pin 2 is Low Voltage Line of Color White
3. Unspecified tolerance refer to Level " 3 "

SPEC NO. :

PAGE : 23/23

**(2) Back view**

