



Silicon FS Planar IGBT



BT40N60BNF

General Description:

Using HUAJING's proprietary Planar design and advanced FS technology, the 600V FSIGBT offers superior conduction and switching performances, high avalanche ruggedness and easy parallel operation.

Features:

- I FS Planar Technology, Positive temperature coefficient
- I Low saturation voltage: $V_{CE(sat)}$, typ = 2.2V
@ $I_C = 40A$ and $T_C = 25^\circ C$
- I Extremely enhanced avalanche capability

Applications:

Aircondition、Welding、UPS...

V_{CES}	600	V
I_C	40	A
P_{tot} ($T_C=25^\circ C$)	312	W
$V_{CE(SAT)}$	2.2	V

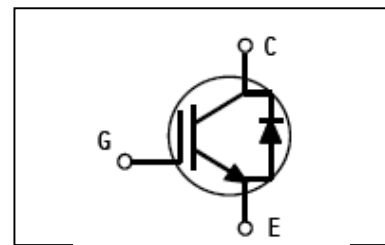
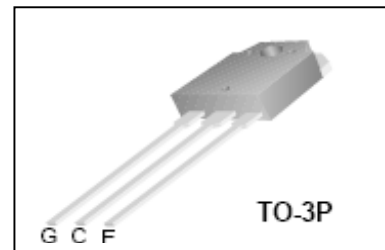

Absolute Maximum Ratings

($T_c = 25^\circ C$ unless otherwise specified):

Symbol	Parameter	Rating	Units
V_{CES}	Collector-Emitter Voltage	600	V
V_{GES}	Gate- Emitter Voltage	± 20	V
I_C	Collector Current	80	A
	Collector Current @ $T_C = 100^\circ C$	40	A
I_{CM}^{a1}	Pulsed Collector Current	120	A
I_F	Diode Continuous Forward Current @ $T_C = 100^\circ C$	20	A
I_{FM}	Diode Maximum Forward Current	100	A
P_D	Power Dissipation @ $T_C = 25^\circ C$	312	W
	Power Dissipation @ $T_C = 100^\circ C$	125	W
T_J, T_{stg}	Operating Junction and Storage Temperature Range	-55 to +150	$^\circ C$
T_L	Maximum Temperature for Soldering	300	$^\circ C$

Thermal Characteristics

Symbol	Parameter	Typ.	Max.	Units
$R_{\theta JC}$	Thermal Resistance, Junction to case for IGBT	--	0.4	$^{\circ}\text{C}/\text{W}$
$R_{\theta JC}$	Thermal Resistance, Junction to case for Diode	--	2.88	$^{\circ}\text{C}/\text{W}$
$R_{\theta JA}$	Thermal Resistance, Junction to Ambient	--	40	$^{\circ}\text{C}/\text{W}$

Electrical Characteristics of the IGBT ($T_c = 25^{\circ}\text{C}$ unless otherwise specified):

OFF Characteristics							
Symbol	Parameter	Test Conditions	Rating			Units	
			Min.	Typ.	Max.		
BV_{CES}	Collector-Emitter Breakdown Voltage	$V_{GE}=0\text{V}, I_{CE}=250\mu\text{A}$	600	--	--	V	
I_{CES}	Collector-Emitter Leakage Current	$V_{GE}=0\text{V}$ $V_{CE}=600\text{V}$	--	--	1.0	mA	
$I_{GES(F)}$	Gate to Emitter Forward Leakage	$V_{GE}=+20\text{V}$	--	--	+250	nA	
$I_{GES(R)}$	Gate to Source Reverse Leakage	$V_{GE}=-20\text{V}$	--	--	-250	nA	

ON Characteristics							
Symbol	Parameter	Test Conditions	Rating			Units	
			Min.	Typ.	Max.		
$V_{CE(sat)}$	Collector-Emitter Saturation Voltage	$I_C=40\text{A}, V_{GE}=15\text{V}$	--	2.2	2.6	V	
$V_{GE(TH)}$	Gate Threshold Voltage	$I_C=1\text{mA}, V_{CE}=V_{GE}$	3.5	4.9	6.5	V	
Pulse width $t_p \leq 380\mu\text{s}, \delta \leq 2\%$							

Dynamic Characteristics							
Symbol	Parameter	Test Conditions	Rating			Units	
			Min.	Typ.	Max.		
C_{ies}	Input Capacitance	$V_{CE}=25\text{V}, V_{GE}=0\text{V}$ $f=1\text{MHz}$	--	1767	--	pF	
C_{oes}	Output Capacitance		--	169	--		
C_{res}	Reverse Transfer Capacitance		--	47	--		

Resistive Switching Characteristics							
Symbol	Parameter	Test Conditions	Rating			Units	
			Min.	Typ.	Max.		
$t_{d(ON)}$	Turn-on Delay Time	$V_{CE}=400\text{V}, I_C=20\text{A}$ $V_{GE}=15\text{V}, R_g=10\Omega$ Inductive Load, $T_a=25^{\circ}\text{C}$	--	33	--	ns	
t_r	Rise Time		--	47	--		
$t_{d(OFF)}$	Turn-Off Delay Time		--	163	--		
t_f	Fall Time		--	66	--		
E_{on}	Turn-On Switching Loss		--	0.71	--	mJ	
E_{off}	Turn-Off Switching Loss		--	0.34	--		
E_{ts}	Total Switching Loss	--	1.05	--			



BT40N60BNF



Q_g	Total Gate Charge	$V_{CE}=400V, I_C=20A$ $V_{GE}=15V$	--	94	--	nC
Q_{ge}	Gate to Emitter Charge		--	15	--	
Q_{gc}	Gate to Collector Charge		--	43	--	

Electrical Characteristics of the DIODE (T_c= 25°C unless otherwise specified):

Symbol	Parameter	Test Conditions	Rating			Units
			Min.	Typ.	Max.	
V_{FM}	Diode Forward Voltage	$I_F=20A$	--	1.6	2.3	V
T_{rr}	Reverse Recovery Time	$I_F=20A$ $di/dt=200A/\mu S$	--	84		ns
I_{rr}	Diode Peak Reverse Recovery Current		--	6		A
Q_{rr}	Reverse Recovery Charge		--	240		nC

Pulse width $t_p \leq 380\mu s, \delta \leq 2\%$

^{a1}: Repetitive rating; pulse width limited by maximum junction temperature

Package Information:

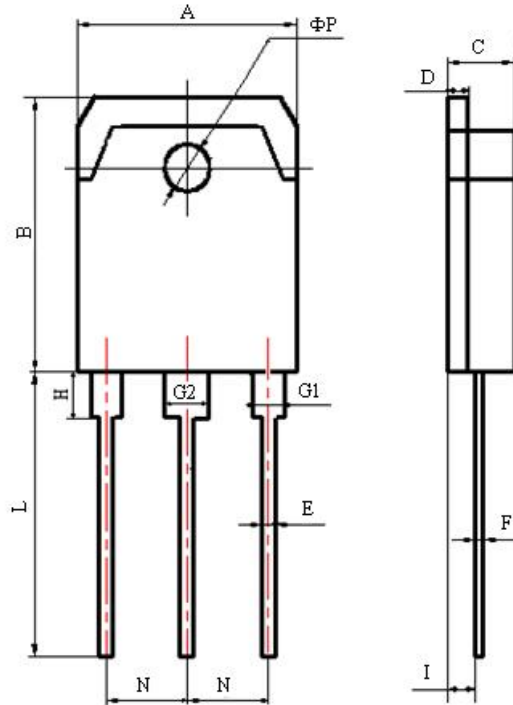

Items	Values(mm)	
	MIN	MAX
A	15.10	15.90
B	19.30	20.30
C	4.70	4.90
D	1.40	1.60
E	0.90	1.10
F	0.50	0.70
G1	2.00	2.20
G2	3.00	3.20
H	3.00	3.70
I	1.20	1.60
	2.70	2.90
L	19.00	21.00
N	5.25	5.65
Φ P	3.10	3.30

TO-3P(N) Package



The name and content of poisonous and harmful material in products

Part's Name	Hazardous Substance					
	Pb	Hg	Cd	Cr(VI)	PBB	PBDE
Limit	≤0.1%	≤0.1%	≤0.01%	≤0.1%	≤0.1%	≤0.1%
Lead Frame	○	○	○	○	○	○
Molding Compound	○	○	○	○	○	○
Chip	○	○	○	○	○	○
Wire Bonding	○	○	○	○	○	○
Solder	×	○	○	○	○	○
Note	Means the hazardous material is under the criterion of SJ/T11363-2006. Means the hazardous material exceeds the criterion of SJ/T11363-2006. The plumbum element of solder exist in products presently, but within the allowed range of Eurogroup's RoHS.					

Warnings

1. Exceeding the maximum ratings of the device in performance may cause damage to the device, even the permanent failure, which may affect the dependability of the machine. It is suggested to be used under 80 percent of the maximum ratings of the device.
2. When installing the heatsink, please pay attention to the torsional moment and the smoothness of the heatsink.
3. IGBTs is the device which is sensitive to the static electricity, it is necessary to protect the device from being damaged by the static electricity when using it.
4. This publication is made by Huajing Microelectronics and subject to regular change without notice.

WUXI CHINA RESOURCES HUAJING MICROELECTRONICS CO., LTD.

Addr: No.14 Liangxi RD. Wuxi, Jiangsu, China Mail:214061 <http://www.crhj.com.cn>
Tel: +86 0510-85807228 Fax: +86- 0510-85800864

Marketing Part: Post: 214061 Tel: +86 0510-81805277/81805336
Fax: +86 0510-85800360/85803016
E-mail: sales@hj.crmicro.com

Application and Service: Post: 214061 Tel / Fax: +86- 0510-81805243/81805110