

ITO-247 Insulated

FEATURES

> IT(RMS):100A > VGT: 1.5V > VDRM VRRM:1200Vand1600V

APPLICATIONS

Washing machine,vacuums, massager,solid state relay , AC Motor speed regulation and so on.

Absolute Maximum Ratings (Tj=25°C unless otherwise specified)

Symbol	Parameter	Conditions	Ratings	Unit
VDRM VRRM	Repetitive Peak Off-State Voltage	BTA100-1200B	1200	V
		BTA100-1600B	1600	
IT(RMS)	R.M.S On-State Current	ITO-247(Ins) Tc=70°C	100	A
ITSM	Surge On-State Current	Tp=20ms	1100	A
I ² t	I ² t for fusing	Tp=10ms	5500	A ² s
PG(AV)	Average Gate Power Dissipation	Tj=125°C	2	W
IGM	Peak Gate Current	Tj=125°C	8	A
PGM	Peak Gate power		10	W
Tj	Operating Junction Temperature		~40~125	°C
TSTG	Storage Temperature		~40~150	

Electrical Characteristics (Tj=25°C unless otherwise specified)

Symbol	Parameter	Test Conditions	Value	Unit	
IDRM	Repetitive Peak Off-State Current	Tj=25°C	20	uA	
		Tj=125°C	12	mA	
IRRM	Repetitive Peak Reverse Current	Tj=25°C	20	uA	
		Tj=125°C	12	mA	
VTM	Forward "on" voltage	IT=80A, tp=380us, Tj=25°C	≤1.5	V	
VGT	Gate trigger voltage	VD=12V, RL=33Ω	≤1.3	V	
di/dt	VD=2/3VDRM Gate Open, Tj=125°C I,I,II,III,IV	F=100Hz, IG=2xIGT, tr≤100ns	100	A/us	
IGT	Gate trigger current	I,I,II,III VD=12V, RL=33Ω	≤50	mA	
IH	Holding current	IT=100mA	≤100		
VGD	Gate non-trigger voltage	VD=VDRM, TJ=125°C, RL=3.3KΩ	0.2	V	
dv/dt	Critical-rate of rise of commutation voltage	TJ=125°C, VD=2/3VDRM, Gate open circuit	≥1500	V/us	
Rth(j-c)	Thermal resistance	Junction to ase	ITO-247(Ins)	0.3	°C/W

FIG1

Maximum power dissipation versus RMS on-state current

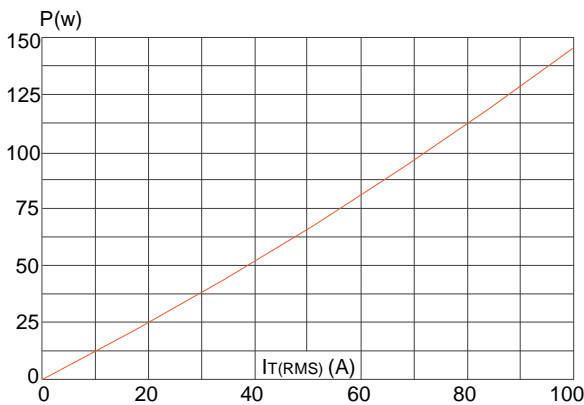

FIG2

RMS on-state current versus case temperature

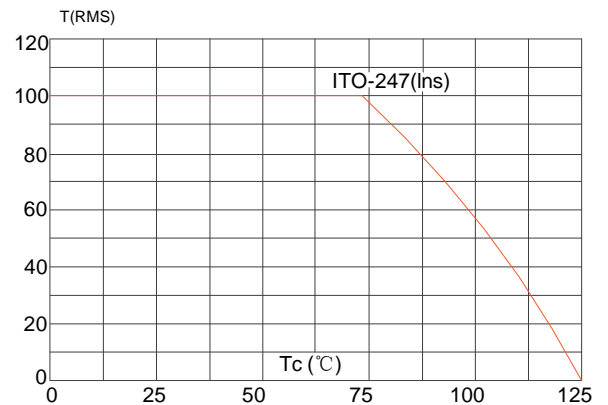

FIG3

Surge peak on-state current versus number of cycles

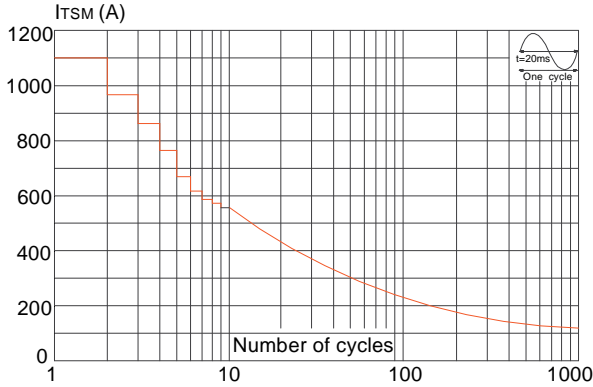

FIG4

On-state characteristics (maximum values)

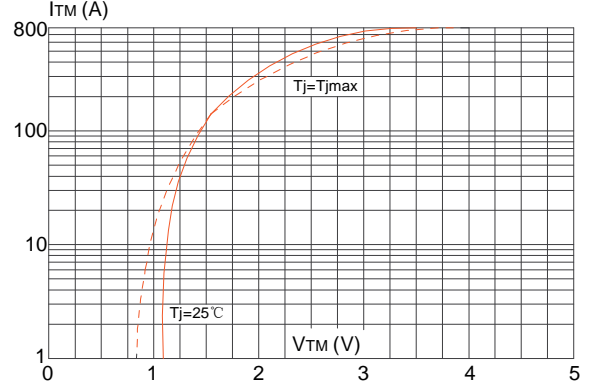

FIG5

Non-repetitive surge peak on-state current for a sinusoidal pulse with width $t_p < 20ms$, and corresponding value of $I^2 t$ ($di/dt < 100A/\mu s$)

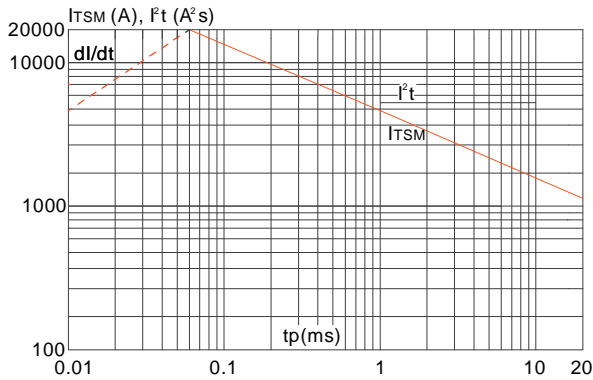
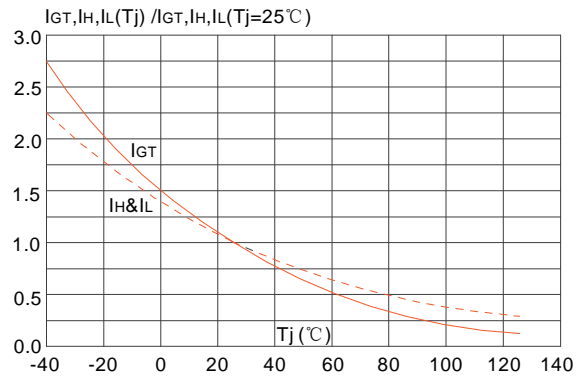
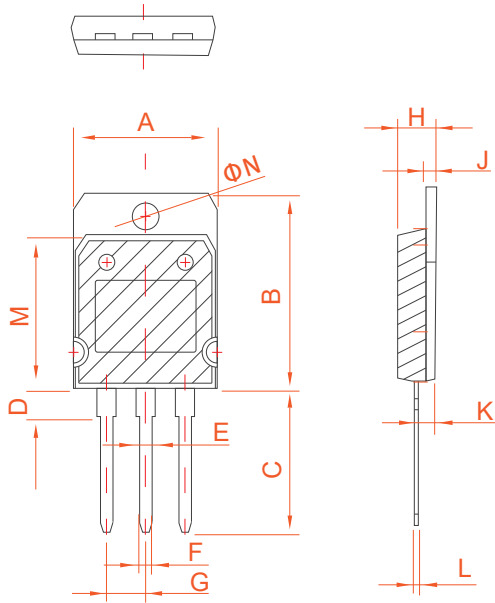

FIG6

FIG.6: Relative variations of gate trigger current, holding current and latching current versus junction temperature



PACKAGE MECHANICAL DATA



ITO-247 (Ins)

Ref.	Dimensions					
	Millimeters			Inches		
	Min.	Typ.	Max.	Min.	Typ.	Max.
A	19.7	19.9	20.1	0.776	0.783	0.791
B	26.9	27.1	27.3	1.059	1.067	1.075
C	19.4	19.9	20.4	0.764	0.783	0.803
D	3.80	3.90	4.00	0.150	0.154	0.157
E	2.56	2.66	2.76	0.101	0.105	0.109
F	1.66	1.76	1.86	0.065	0.069	0.073
G		5.45			0.215	
H	5.05	5.10	5.50	0.199	0.201	0.217
J	1.45	1.50	1.55	0.057	0.059	0.061
K	2.20	2.30	2.40	0.087	0.091	0.094
L	0.60	0.70	0.80	0.024	0.028	0.031
M	21.2	21.3	21.4	0.835	0.839	0.843
N	3.20	3.30	3.40	0.126	0.130	0.134



Information furnished is believed to be accurate and reliable. However, Shenzhen HanKingyuan Electronic assumes no responsibility for the consequences of use of such information nor for any infringement of patents or other rights of third parties which may result from its use. Specifications mentioned in this publication are subject to change without notice. This publication supersedes and replaces all information previously supplied.

The KY logo is a registered trademark of Shenzhen HanKingyuan Electronic.

©2013 Shenzhen HanKingyuan Electronic - Printed in Shenzhen - All Rights Reserved