

PNP Epitaxial Planar Transistor

BTA1505E3

Description

The BTA1505E3 is a PNP Darlington transistor, designed for use in general purpose amplifier and low speed switching application. Pb-free lead plating package process is adopted.

Equivalent Circuit

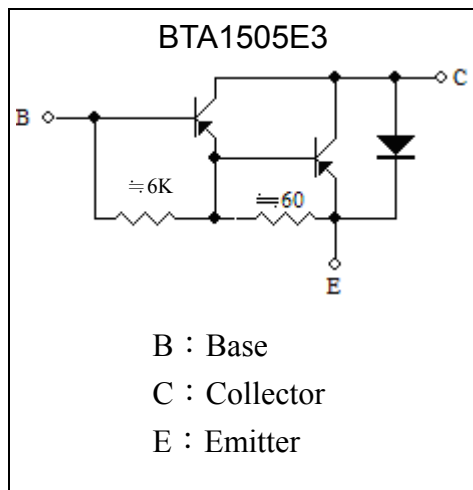

Outline

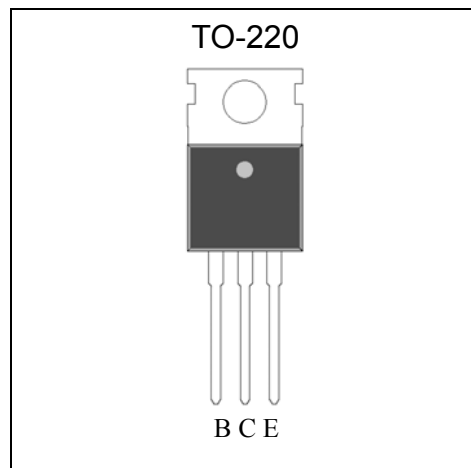

Ordering Information

Device	Package	Shipping
BTA1505E3-0-UB-S	TO-220 (RoHS compliant package)	50 pcs/tube, 20 tubes/box, 4 boxes / carton

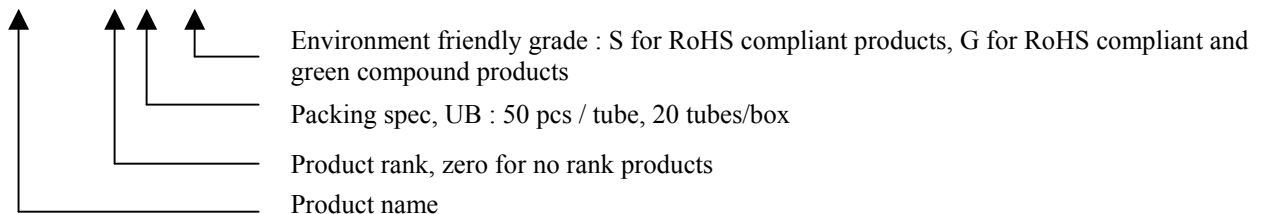



Absolute Maximum Ratings (Ta=25°C)

Parameter	Symbol	Limits	Unit
Collector-Base Voltage	V _{CB0}	-150	V
Collector-Emitter Voltage	V _{CEO}	-150	
Emitter-Base Voltage	V _{EBO}	-5	
Collector Current (DC)	I _C	-5	A
Collector Current (Pulse)	I _{CP}	-10 (Note 1)	
Power Dissipation @ T _A =25°C	P _D	2	W
Power Dissipation @ T _C =25°C		20	
Thermal Resistance, Junction to Ambient	R _{θJA}	62.5	°C/W
Thermal Resistance, Junction to Case	R _{θJC}	6.2	
Operating Junction Temperature Range	T _j	-55~+150	°C
Storage Temperature Range	T _{stg}	-55~+150	

Note : 1. Single Pulse P_w ≤ 350μs, Duty ≤ 2%.

Characteristics (Ta=25°C)

Symbol	Min.	Typ.	Max.	Unit	Test Conditions
BV _{CEO}	-150	-	-	V	I _C =-1mA, I _B =0
BV _{CB0}	-150	-	-		I _C =-100μA, I _E =0
I _{CBO}	-	-	-100	nA	V _{CB} =-150V, I _E =0
I _{CEO}	-	-	-1	μA	V _{CE} =-150V, I _B =0
I _{EBO}	-	-	-2	mA	V _{EB} =-5V, I _C =0
*V _{CE(sat)}	-	-	-1.2	V	I _C =-2A, I _B =-2mA
	-	-	-1.5		I _C =-3A, I _B =-12mA
	-	-	-2.5		I _C =-4A, I _B =-20mA
*V _{BE(sat)}	-	-	-2.3	-	I _C =-3A, I _B =-12mA
*V _{BE(on)}	-	-	-2.5	-	V _{CE} =-3V, I _C =-3A
*h _{FE1}	1000	-	-	-	V _{CE} =-3V, I _C =-500mA
*h _{FE2}	1000	-	-	-	V _{CE} =-3V, I _C =-1A
*h _{FE3}	1000	-	-	-	V _{CE} =-3V, I _C =-3A
V _{FEC}	-	-	-2	V	I _C =-4A
C _{ob}	-	-	200	pF	V _{CB} =-10V, I _E =0A, f=1MHz

*Pulse Test : Pulse Width ≤ 380μs, Duty Cycle ≤ 2%

Typical Characteristics

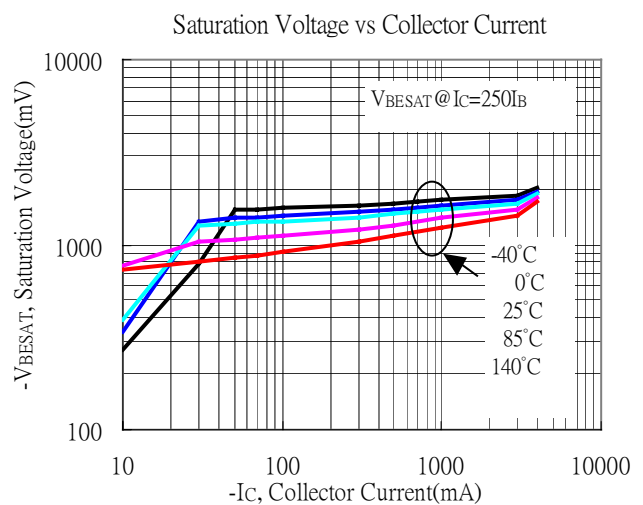
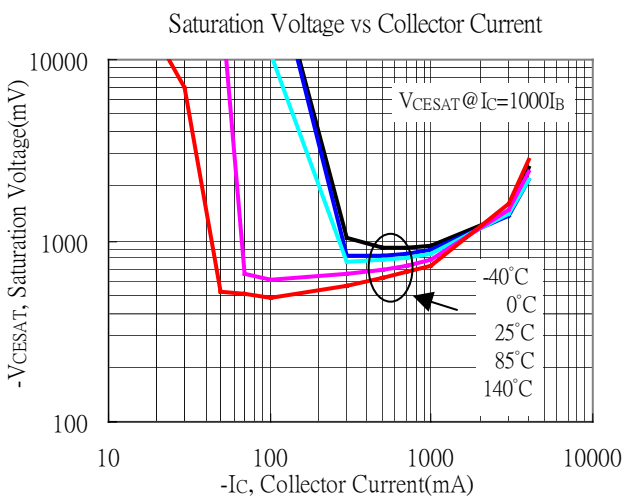
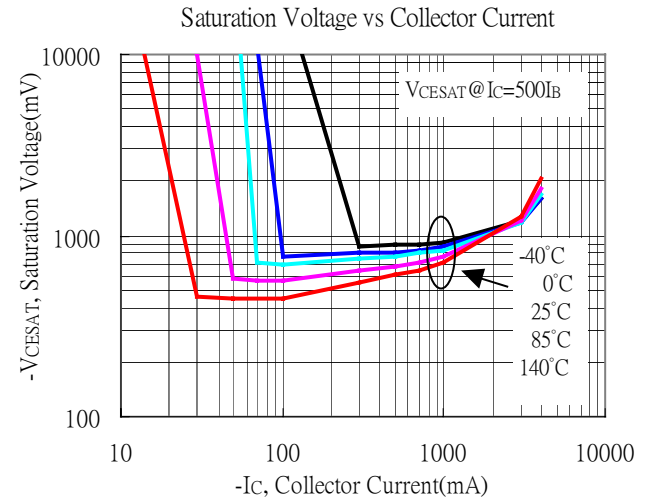
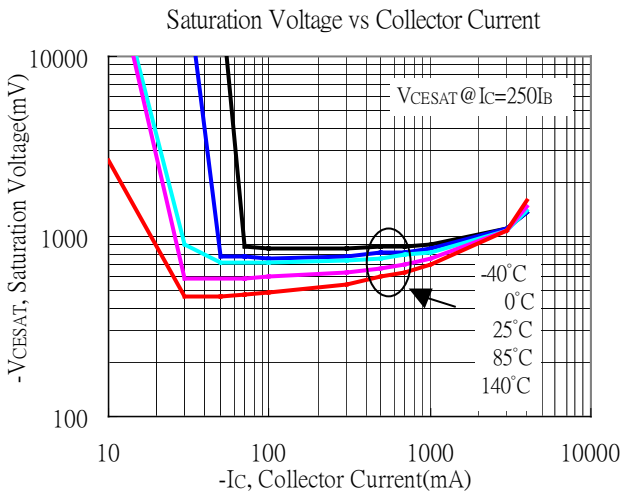
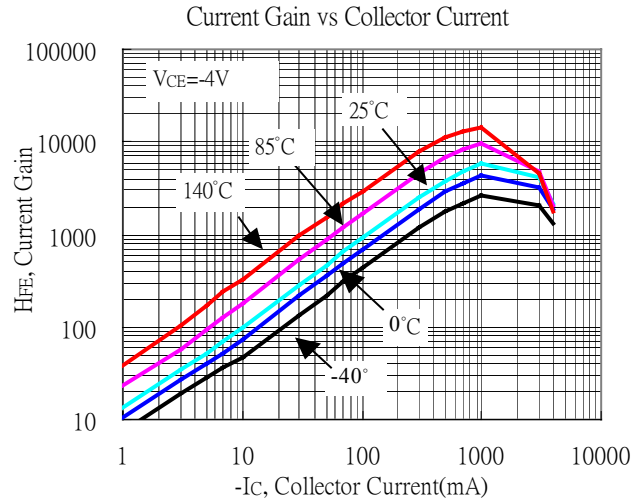
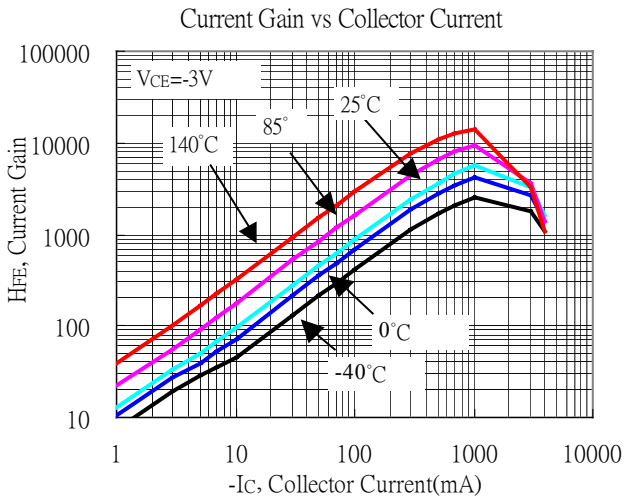

Typical Characteristics(Cont.)

On Voltage vs Collector Current

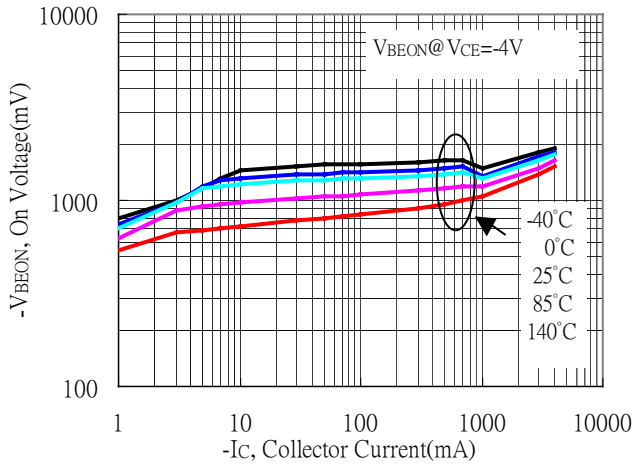

Built-in Diode Characteristics

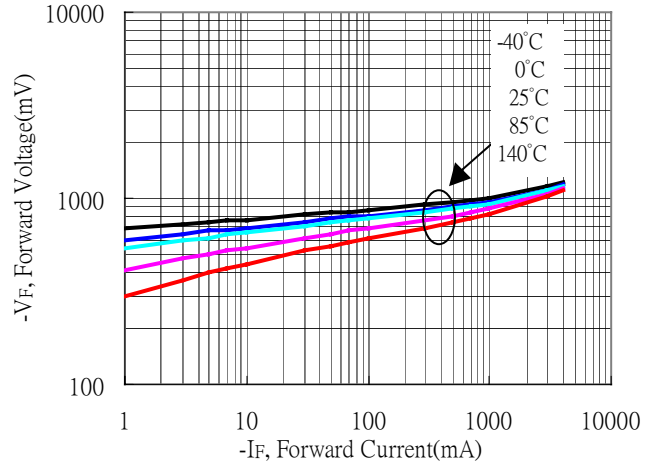

Capacitance vs Reverse-Biased Voltage

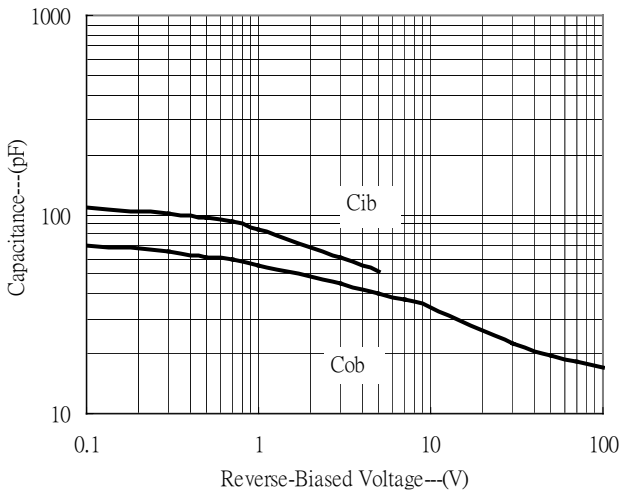

Power Derating Curve

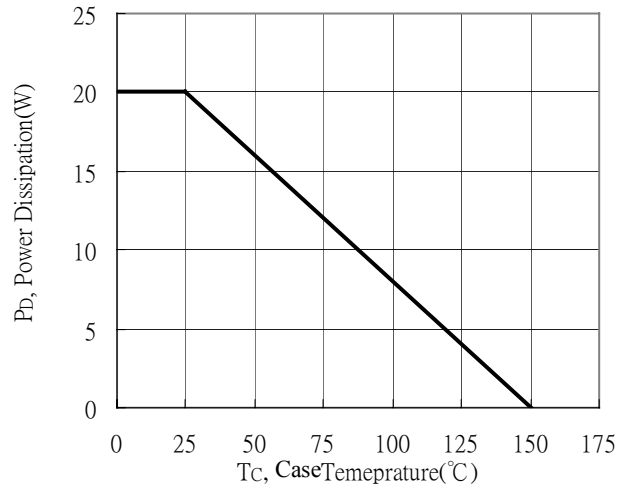

Power Derating Curve

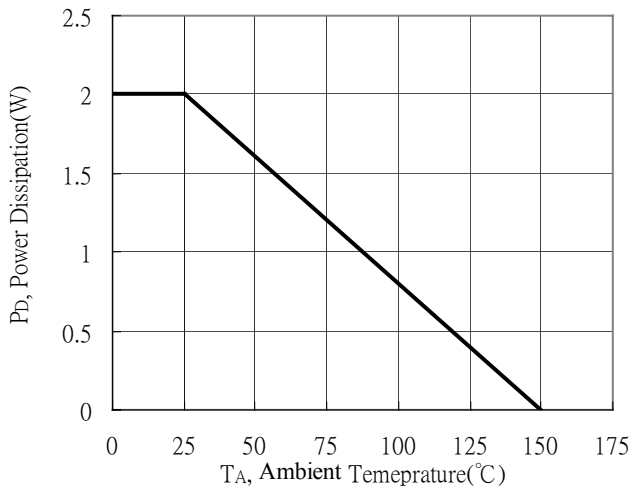

Recommended wave soldering condition

Product	Peak Temperature	Soldering Time
Pb-free devices	260 +0/-5 °C	5 +1/-1 seconds

Recommended temperature profile for IR reflow

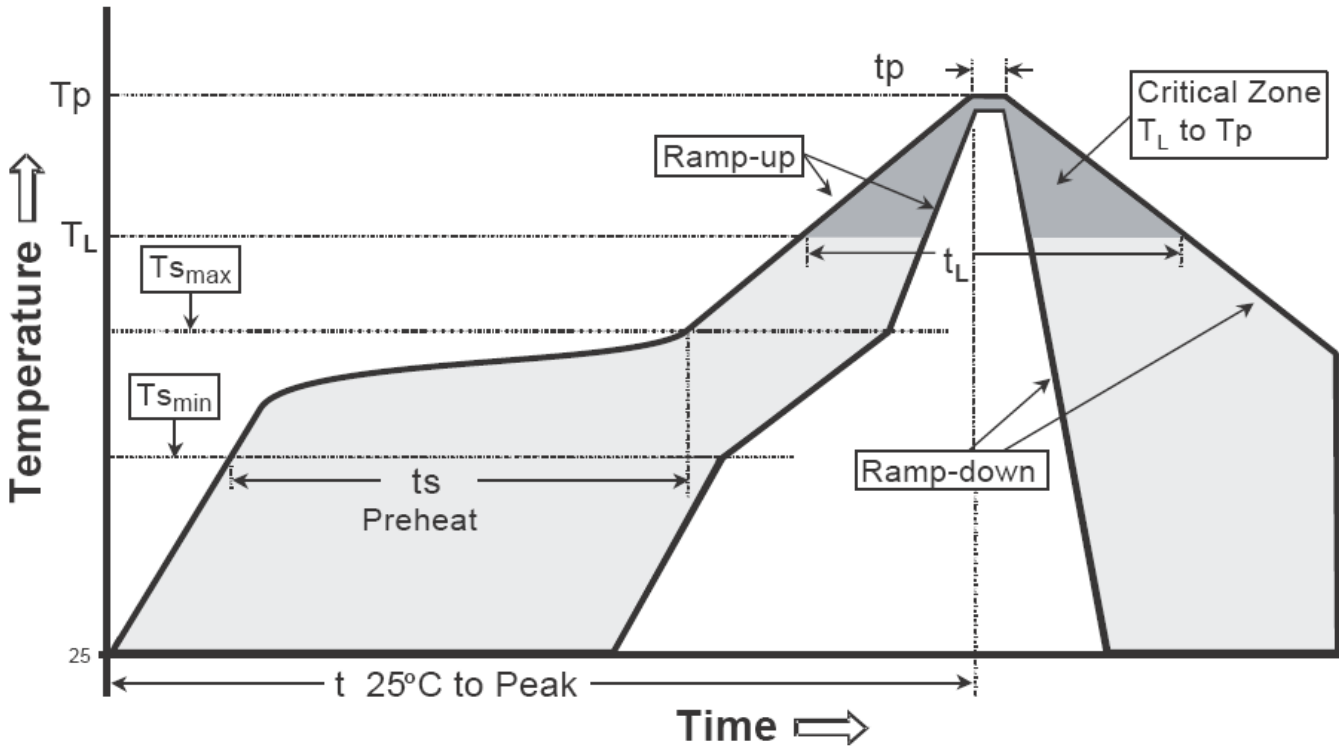

Profile feature	Sn-Pb eutectic Assembly	Pb-free Assembly
Average ramp-up rate (T _{smax} to T _p)	3°C/second max.	3°C/second max.
Preheat		
-Temperature Min(T _{s min})	100°C	150°C
-Temperature Max(T _{s max})	150°C	200°C
-Time(t _{s min} to t _{s max})	60-120 seconds	60-180 seconds
Time maintained above:		
-Temperature (T _L)	183°C	217°C
- Time (t _L)	60-150 seconds	60-150 seconds
Peak Temperature(T _P)	240 +0/-5 °C	260 +0/-5 °C
Time within 5°C of actual peak temperature(tp)	10-30 seconds	20-40 seconds
Ramp down rate	6°C/second max.	6°C/second max.
Time 25 °C to peak temperature	6 minutes max.	8 minutes max.

Note : All temperatures refer to topside of the package, measured on the package body surface.

TO-220 Dimension

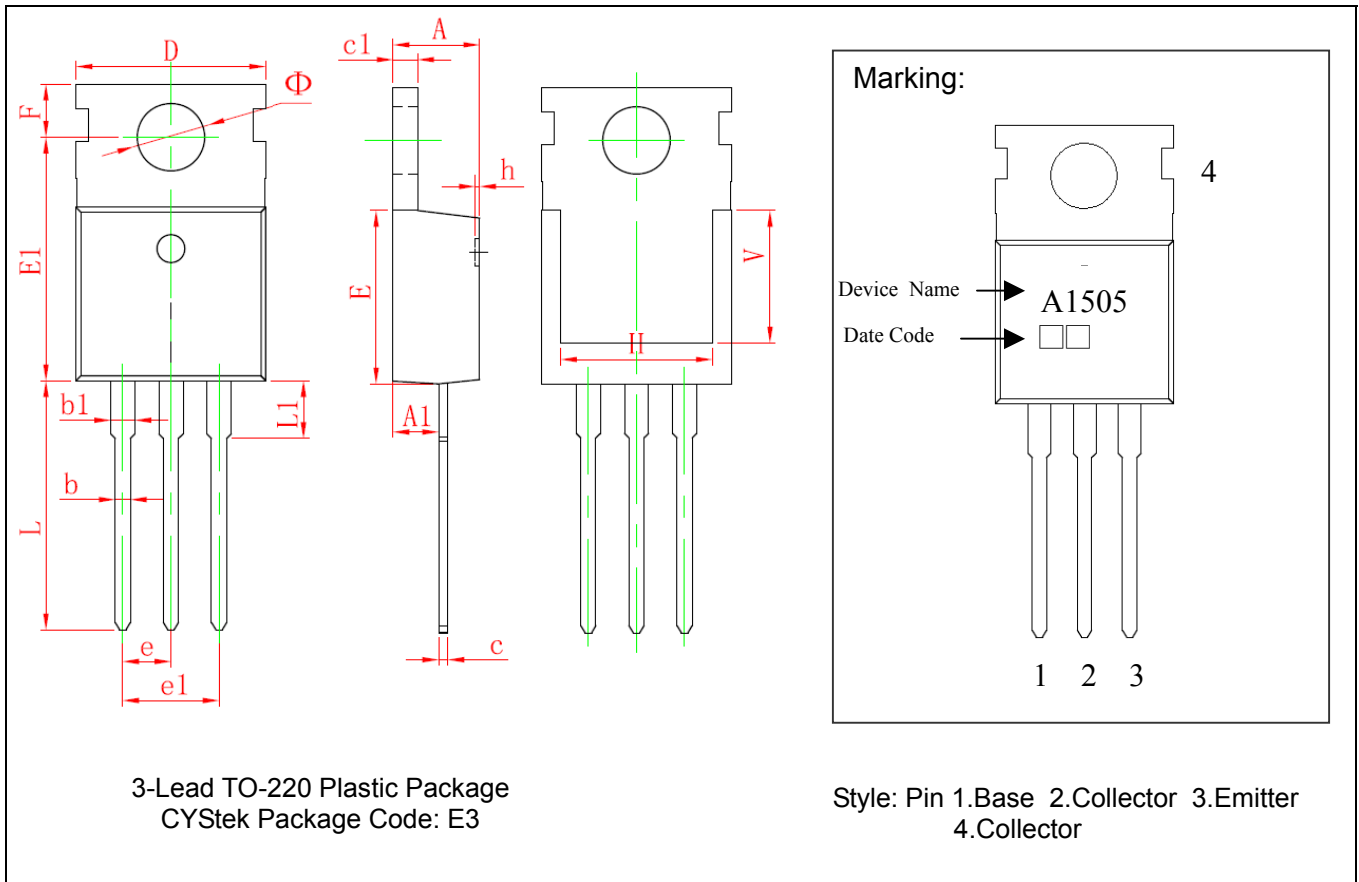

*: Typical

DIM	Millimeters		Inches		DIM	Millimeters		Inches	
	Min.	Max.	Min.	Max.		Min.	Max.	Min.	Max.
A	4.400	4.600	0.173	0.181	e	2.540*		0.100*	
A1	2.250	2.550	0.089	0.100	e1	4.980	5.180	0.196	0.204
b	0.710	0.910	0.028	0.036	F	2.650	2.950	0.104	0.116
b1	1.170	1.370	0.046	0.054	H	7.900	8.100	0.311	0.319
c	0.330	0.650	0.013	0.026	h	0.000	0.300	0.000	0.012
c1	1.200	1.400	0.047	0.055	L	12.900	13.400	0.508	0.528
D	9.910	10.250	0.390	0.404	L1	2.850	3.250	0.112	0.128
E	8.950	9.750	0.352	0.384	V	7.500	REF	0.295	REF
E1	12.650	12.950	0.498	0.510	Φ	3.400	3.800	0.134	0.150

Notes: 1.Controlling dimension: millimeters.
 2.Maximum lead thickness includes lead finish thickness, and minimum lead thickness is the minimum thickness of base material.
 3.If there is any question with packing specification or packing method, please contact your local CYStek sales office.

Material:

- Lead: Pure tin plated.
- Mold Compound: Epoxy resin family, flammability solid burning class: UL94V-0.

Important Notice:

- All rights are reserved. Reproduction in whole or in part is prohibited without the prior written approval of CYStek.
- CYStek reserves the right to make changes to its products without notice.
- CYStek **semiconductor products are not warranted to be suitable for use in Life-Support Applications, or systems.**
- CYStek assumes no liability for any consequence of customer product design, infringement of patents, or application assistance.