

High Voltage PNP Epitaxial Planar Transistor

BTA1759N3

BV_{CEO}	-400V
I_C	-0.3A
$V_{CESAT(TYP)}$	-0.08V

Description

- High breakdown voltage. ($BV_{CEO}=-400V$)
- Low saturation voltage, typical $V_{CE(sat)} = -0.2V$ at $I_C/I_B = -20mA/-2mA$.
- Wide SOA (safe operation area).
- Complementary to BTC4505N3.
- Pb-free lead plating and halogen-free package

Symbol

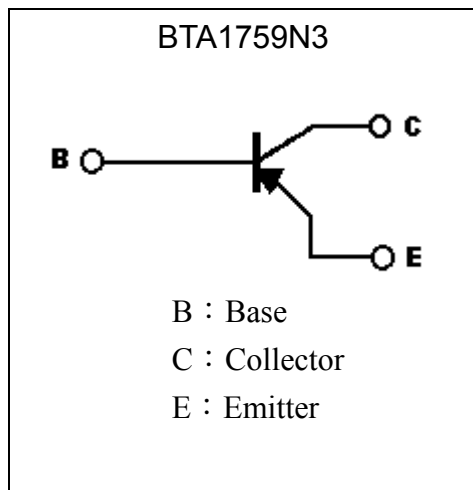

Outline

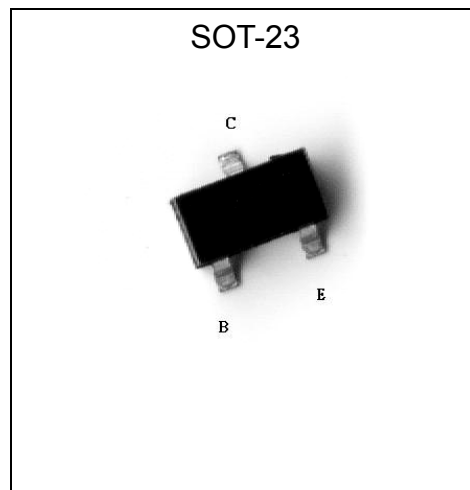

Ordering Information

Device	Package	Shipping
BTA1759N3-0-T1-G	SOT-23 (Pb-free lead plating and halogen-free package)	3000 pcs / tape & reel

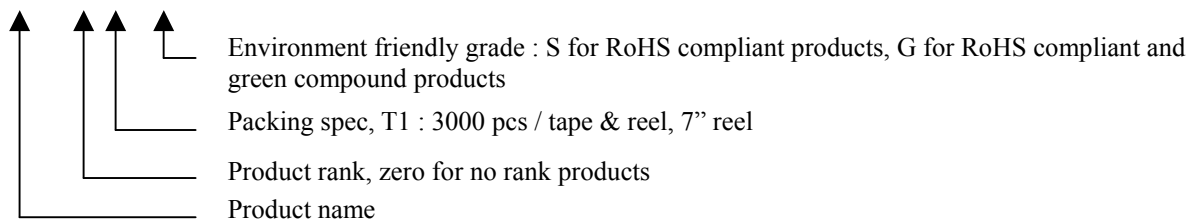

**Absolute Maximum Ratings** (Ta=25°C)

Parameter	Symbol	Limits	Unit
Collector-Base Voltage	V _{CB0}	-400	V
Collector-Emitter Voltage	V _{CEO}	-400	V
Emitter-Base Voltage	V _{EBO}	-7	V
Collector Current	I _C	-300	mA
Power Dissipation	P _d	225	mW
Junction Temperature	T _j	150	°C
Storage Temperature	T _{stg}	-55~+150	°C

Thermal Data

Parameter	Symbol	Value	Unit
Thermal Resistance, Junction-to-case, max	R _{th,j-c}	180	°C/W
Thermal Resistance, Junction-to-ambient, max	R _{th,j-a}	556	

Characteristics (Ta=25°C)

Symbol	Min.	Typ.	Max.	Unit	Test Conditions
BV _{CB0}	-400	-	-	V	I _C =-50μA
BV _{CEO}	-400	-	-	V	I _C =-1mA
BV _{EBO}	-7	-	-	V	I _E =-50μA
I _{CB0}	-	-	-100	nA	V _{CB} =-400V
I _{CER}	-	-	-10	nA	V _{CE} =-300V, R _{EB} =4kΩ
I _{EBO}	-	-	-100	nA	V _{EB} =-6V
*V _{CE(sat)}	-	-0.08	-0.5	V	I _C =-20mA, I _B =-2mA
*V _{BE(sat)}	-	-	-1.2	V	I _C =-20mA, I _B =-2mA
*h _{FE}	100	-	270	-	V _{CE} =-10V, I _C =-10mA
f _T	-	12	-	MHz	V _{CE} =-10V, I _C =-10mA, f=5MHz
C _{ob}	-	13	-	pF	V _{CB} =-10V, I _E =0A, f=1MHz

*Pulse Test: Pulse Width ≤380μs, Duty Cycles≤2%

Characteristic Curves

Current Gain vs Collector Current

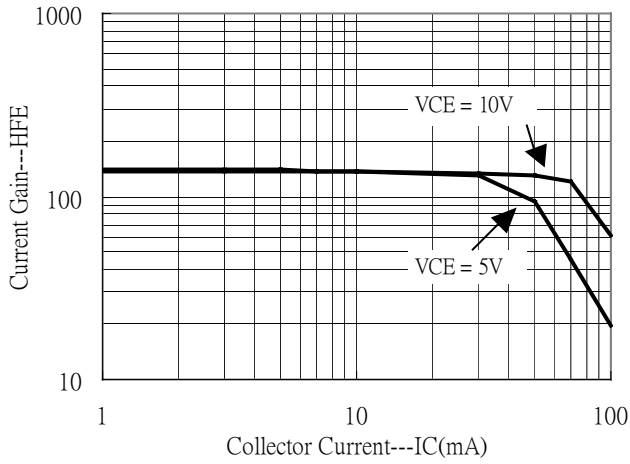

Saturation Voltage vs Collector Current

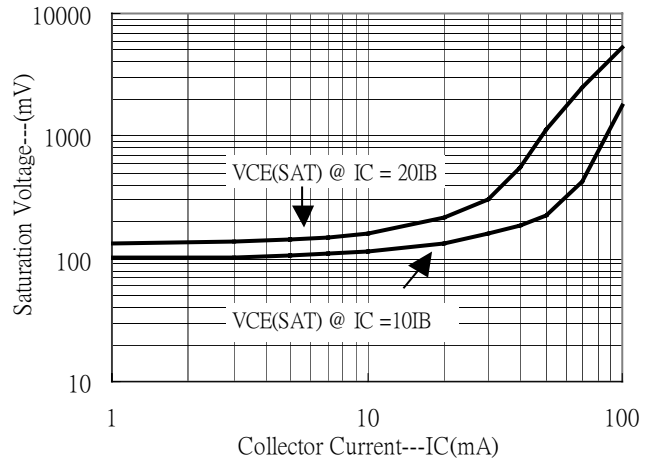

Saturation Voltage vs Collector Current

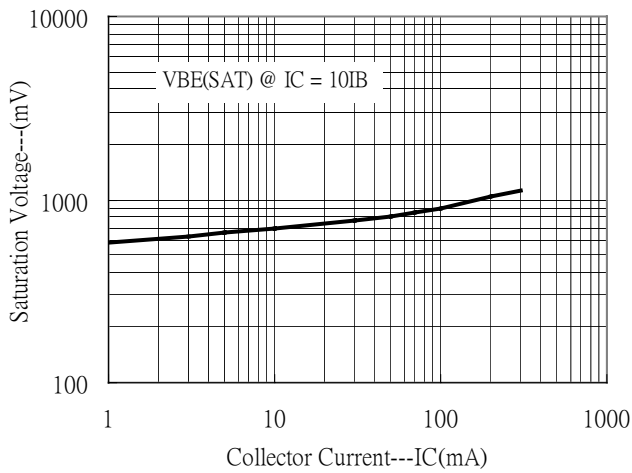

Power Derating Curve

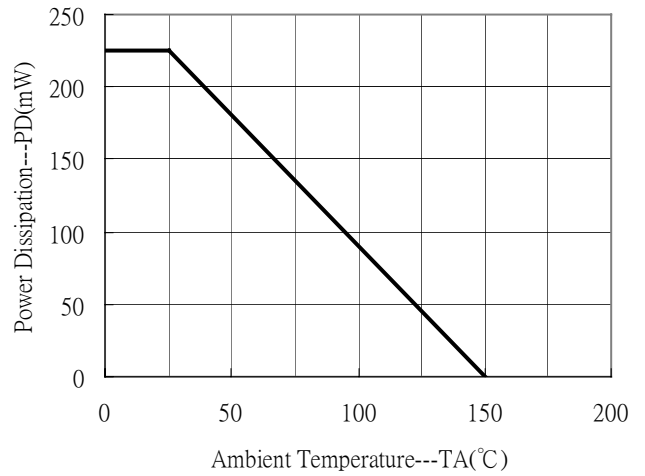

Reel Dimension

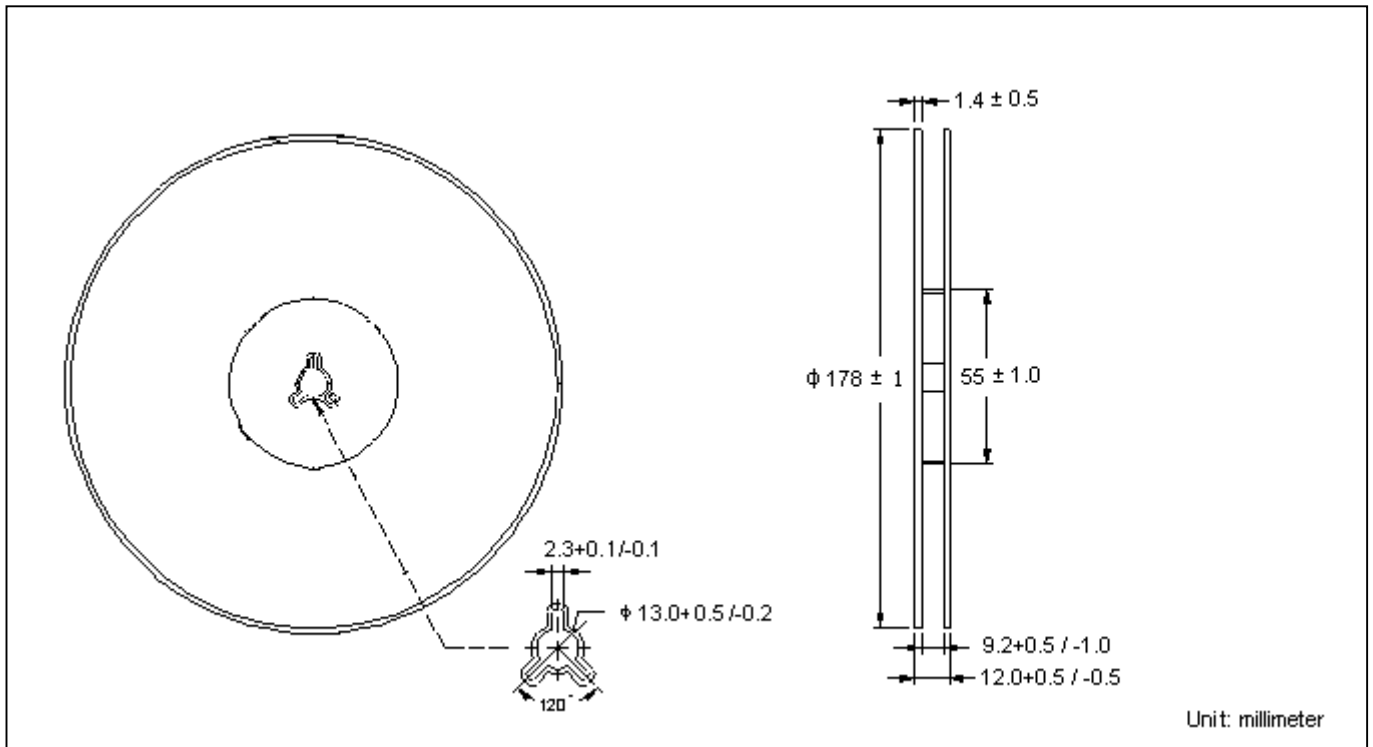

Carrier Tape Dimension

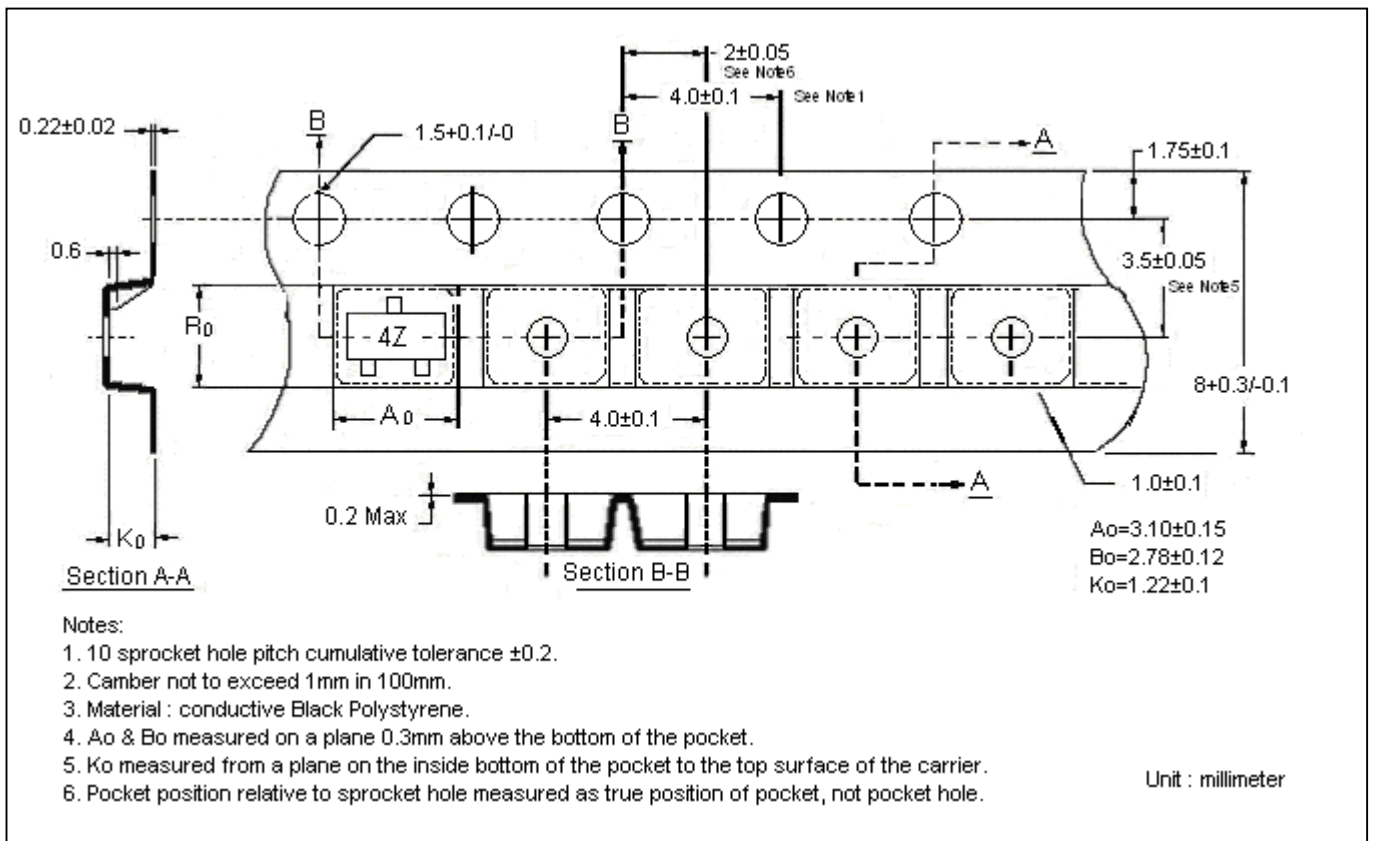

Recommended Soldering Footprint

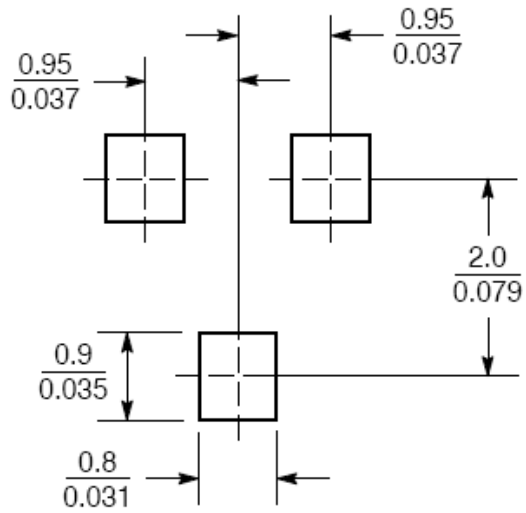

Unit : $\frac{\text{mm}}{\text{inches}}$

Recommended wave soldering condition

Product	Peak Temperature	Soldering Time
Pb-free devices	260 +0/-5 °C	5 +1/-1 seconds

Recommended temperature profile for IR reflow

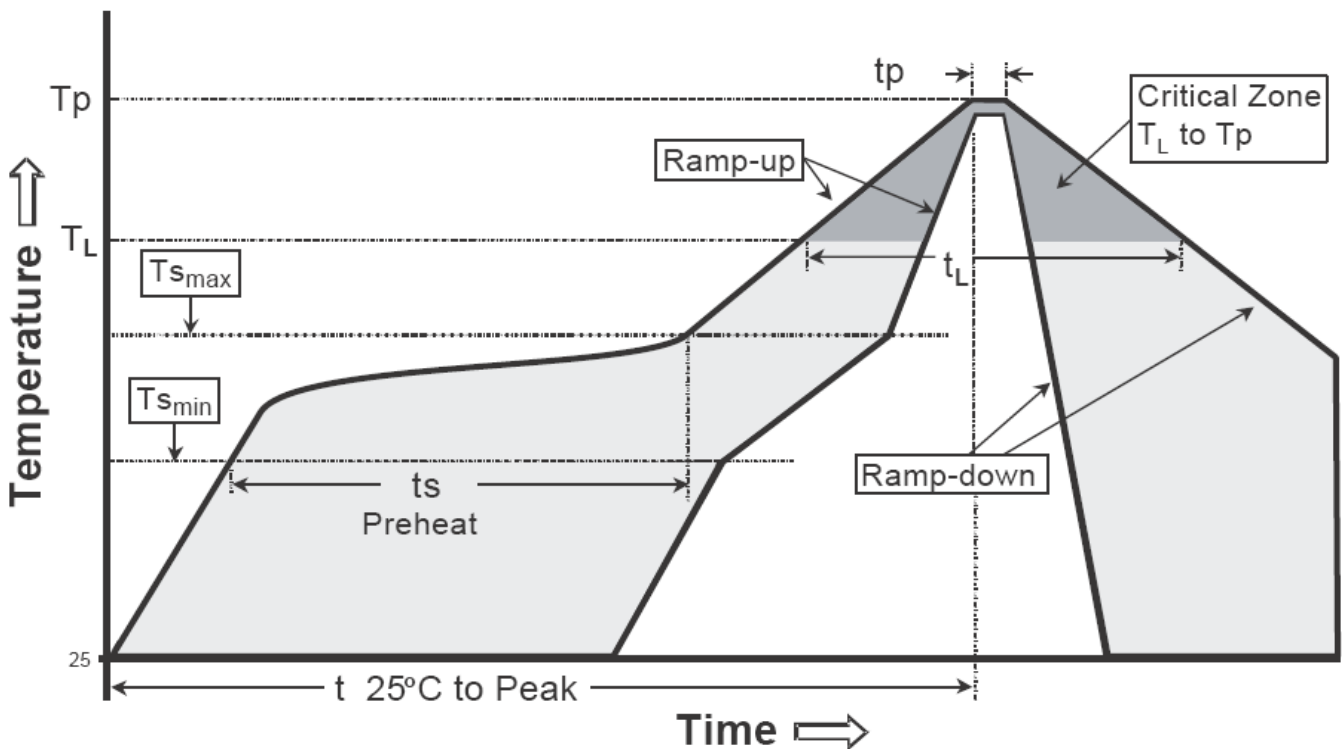

Profile feature	Sn-Pb eutectic Assembly	Pb-free Assembly
Average ramp-up rate (Tsmax to Tp)	3°C/second max.	3°C/second max.
Preheat		
-Temperature Min(Ts min)	100°C	150°C
-Temperature Max(Ts max)	150°C	200°C
-Time(ts min to ts max)	60-120 seconds	60-180 seconds
Time maintained above:		
-Temperature (Tl)	183°C	217°C
- Time (tl)	60-150 seconds	60-150 seconds
Peak Temperature(Tp)	240 +0/-5 °C	260 +0/-5 °C
Time within 5°C of actual peak temperature(tp)	10-30 seconds	20-40 seconds
Ramp down rate	6°C/second max.	6°C/second max.
Time 25 °C to peak temperature	6 minutes max.	8 minutes max.

Note : All temperatures refer to topside of the package, measured on the package body surface.

SOT-23 Dimension

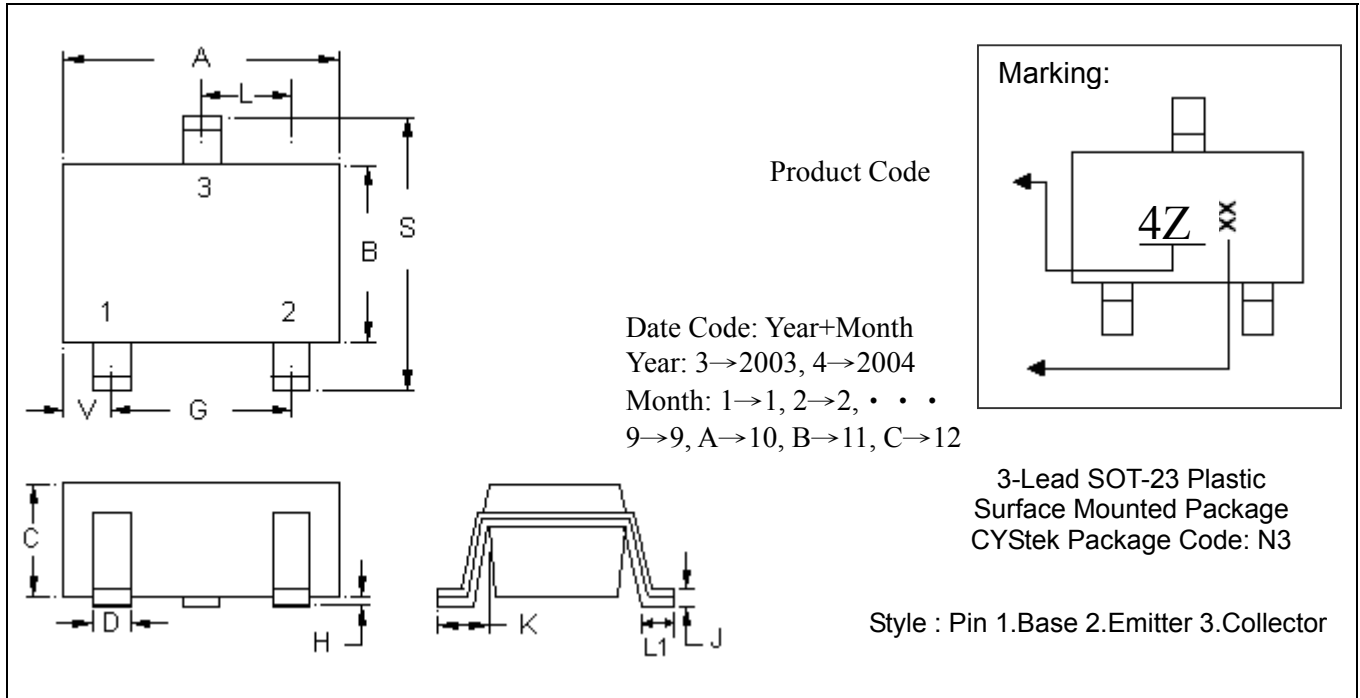

*:Typical

DIM	Inches		Millimeters		DIM	Inches		Millimeters	
	Min.	Max.	Min.	Max.		Min.	Max.	Min.	Max.
A	0.1102	0.1204	2.80	3.04	J	0.0032	0.0079	0.08	0.20
B	0.0472	0.0669	1.20	1.70	K	0.0118	0.0266	0.30	0.67
C	0.0335	0.0512	0.89	1.30	L	0.0335	0.0453	0.85	1.15
D	0.0118	0.0197	0.30	0.50	S	0.0830	0.1161	2.10	2.95
G	0.0669	0.0910	1.70	2.30	V	0.0098	0.0256	0.25	0.65
H	0.0000	0.0040	0.00	0.10	L1	0.0118	0.0197	0.30	0.50

- Notes :** 1.Controlling dimension : millimeters.
 2.Maximum lead thickness includes lead finish thickness, and minimum lead thickness is the minimum thickness of base material.
 3.If there is any question with packing specification or packing method, please contact your local CYStek sales office.

Material :

- Lead : Pure tin plated..
- Mold Compound : Epoxy resin family, flammability solid burning class:UL94V-0.

Important Notice:

- All rights are reserved. Reproduction in whole or in part is prohibited without the prior written approval of CYStek.
- CYStek reserves the right to make changes to its products without notice.
- CYStek **semiconductor products are not warranted to be suitable for use in Life-Support Applications, or systems.**
- CYStek assumes no liability for any consequence of customer product design, infringement of patents, or application assistance.