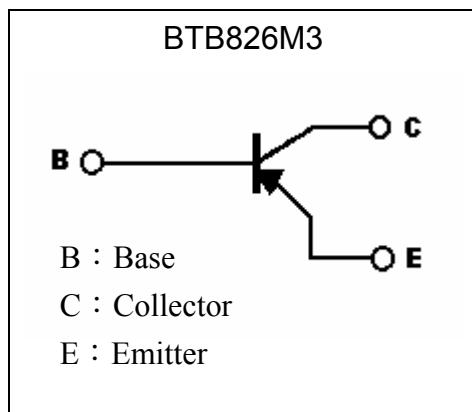
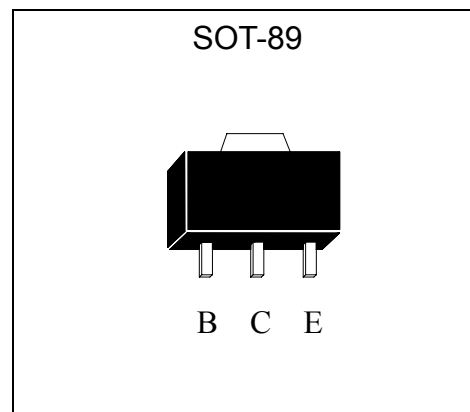

Low Vcesat PNP Epitaxial Planar Transistor

BTB826M3

Features

- Low $V_{CE(sat)}$, $V_{CE(sat)} = -0.65$ V (typical), at $I_C / I_B = -3A / -0.1A$
- Excellent current gain characteristics
- Pb-free lead plating package

Symbol

Outline

Absolute Maximum Ratings ($T_a = 25^\circ\text{C}$)

Parameter	Symbol	Limits	Unit
Collector-Base Voltage	V_{CBO}	-50	V
Collector-Emitter Voltage	V_{CEO}	-30	V
Emitter-Base Voltage	V_{EBO}	-5	V
Collector Current (DC)	I_C	-3	A
Collector Current (Pulse)	I_{CP}	-6 (Note 1)	A
Power Dissipation	P_d	0.5	W
Power Dissipation	P_d	2 (Note 2)	W
ESD susceptibility		8000 (Note 3)	V
Junction Temperature	T_j	150	$^\circ\text{C}$
Storage Temperature	T_{stg}	-55~+150	$^\circ\text{C}$

- Note : 1. Single Pulse , $P_w = 10\text{ms}$
 2. When mounting on a $40 \times 40 \times 0.7$ mm ceramic board.
 3. Human body model, $1.5\text{k}\Omega$ in series with 100pF

**Characteristics (Ta=25°C)**

Symbol	Min.	Typ.	Max.	Unit	Test Conditions
BV _{CBO}	-50	-	-	V	I _C =-50μA, I _E =0
BV _{CEO}	-30	-	-	V	I _C =-1mA, I _B =0
BV _{EBO}	-5	-	-	V	I _E =-50μA, I _C =0
I _{CBO}	-	-	-100	nA	V _{CB} =-40V, I _E =0
I _{CEO}	-	-	-100	μA	V _{CE} =-30V, I _B =0
I _{EBO}	-	-	-100	nA	V _{EB} =-5V, I _C =0
*V _{CE(sat)}	-	-	-0.4	V	I _C =-1A, I _B =-50mA
*V _{CE(sat)}	-	-	-0.7	V	I _C =-2A, I _B =-100mA
*V _{CE(sat)}	-	-	-1	V	I _C =-3A, I _B =-100mA
*V _{BE(sat)}	-	-	-1.2	V	I _C =-2A, I _B =-100mA
*h _{FE}	160	-	-	-	V _{CE} =-2V, I _C =-100mA
*h _{FE}	180	-	560	-	V _{CE} =-3V, I _C =-500mA
*h _{FE}	100	-	-	-	V _{CE} =-2V, I _C =-1A
*h _{FE}	60	-	-	-	V _{CE} =-2V, I _C =-3A
f _T	-	180	-	MHz	V _{CE} =-5V, I _C =-100mA, f=100MHz
Cob	-	20	-	pF	V _{CB} =-10V, f=1MHz

*Pulse Test : Pulse Width ≤380μs, Duty Cycle≤2%

Classification Of h_{FE}

Rank	R	S
Range	180~390	270~560

Ordering Information

Device	Package	Shipping
BTB826M3	SOT-89 (Pb-free lead plating)	1000 pcs / Tape & Reel

Typical Characteristics

Emitter Grounded Output Characteristics

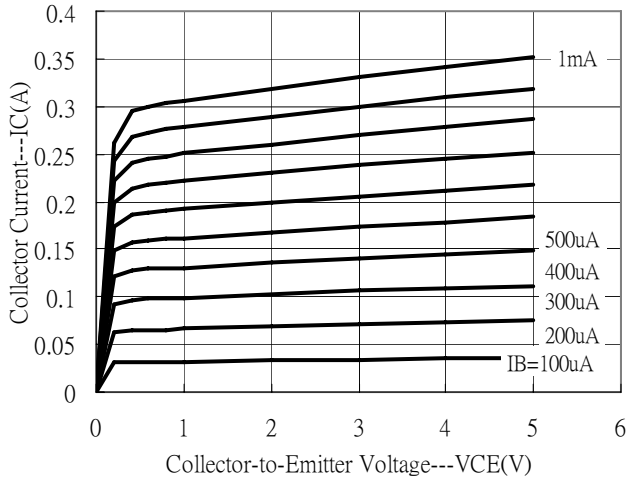

Emitter Grounded Output Characteristics

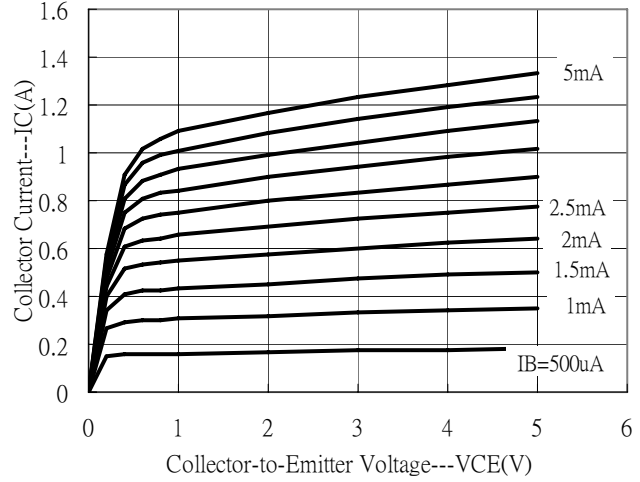

Emitter Grounded Output Characteristics

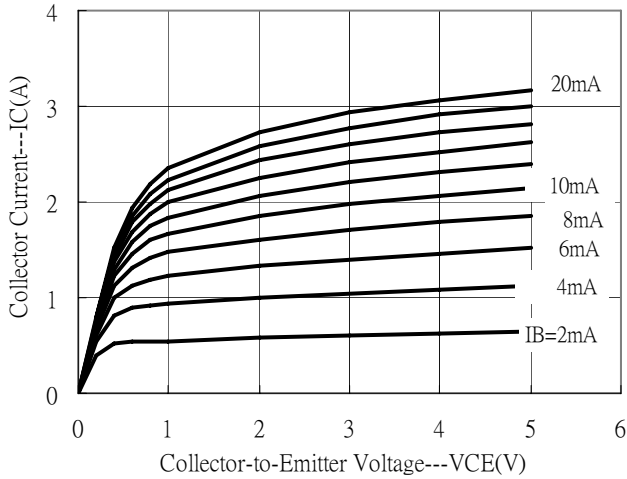

Emitter Grounded Output Characteristics

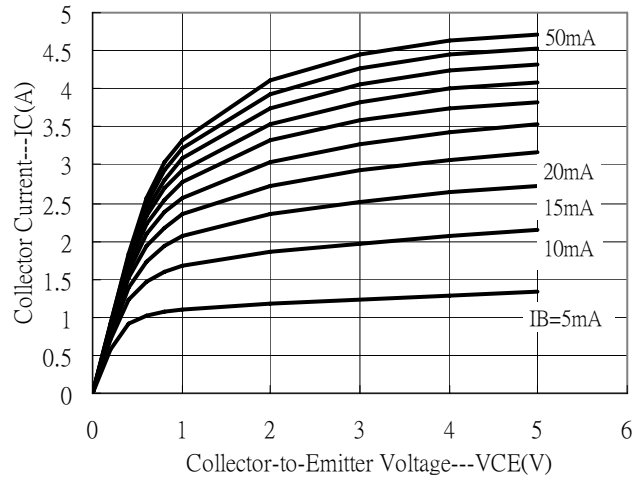

Current Gain vs Collector Current

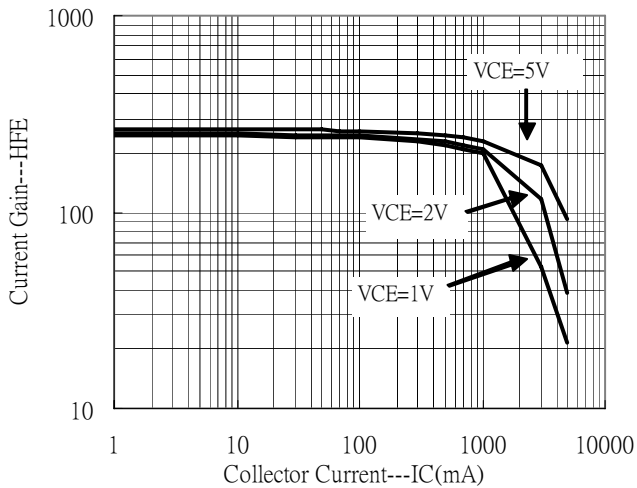

Saturation Voltage vs Collector Current

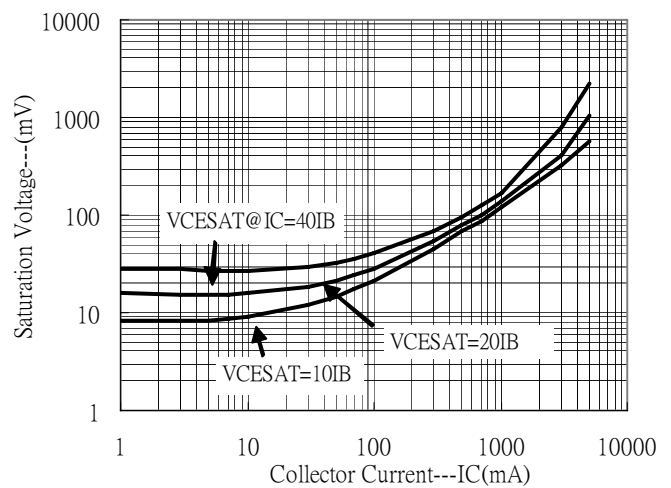

Typical Characteristics(Cont.)

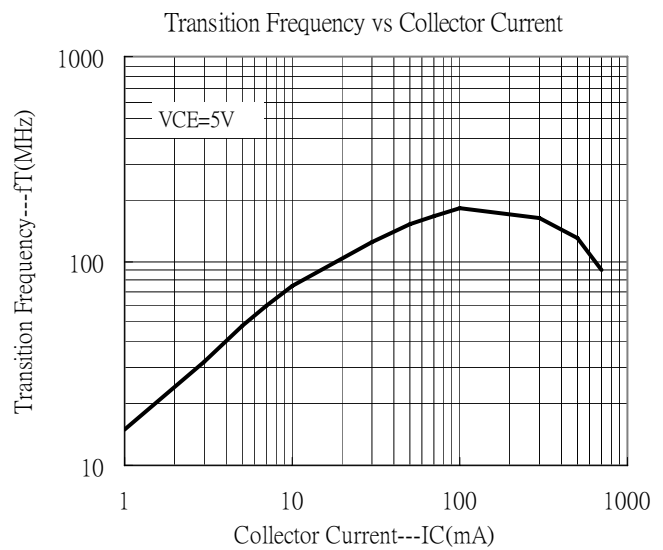
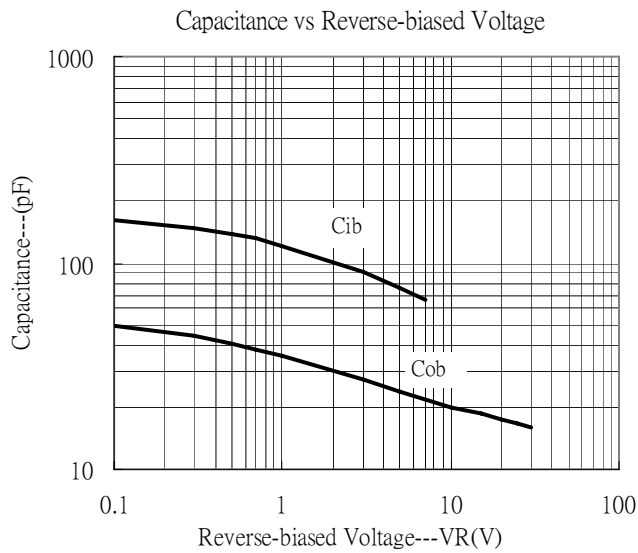
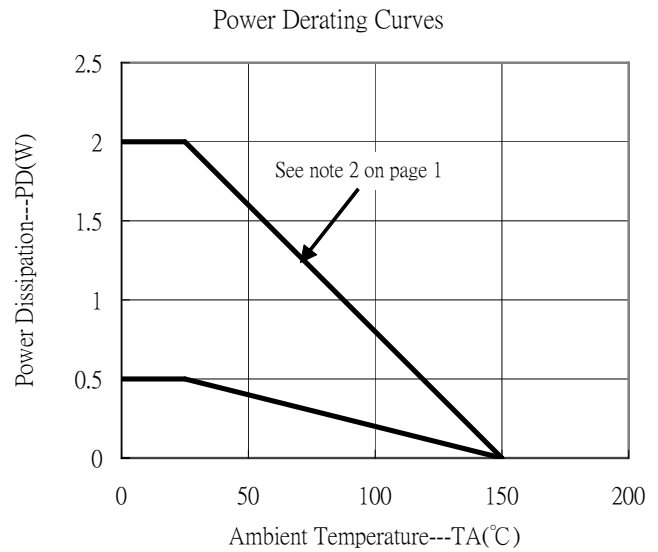
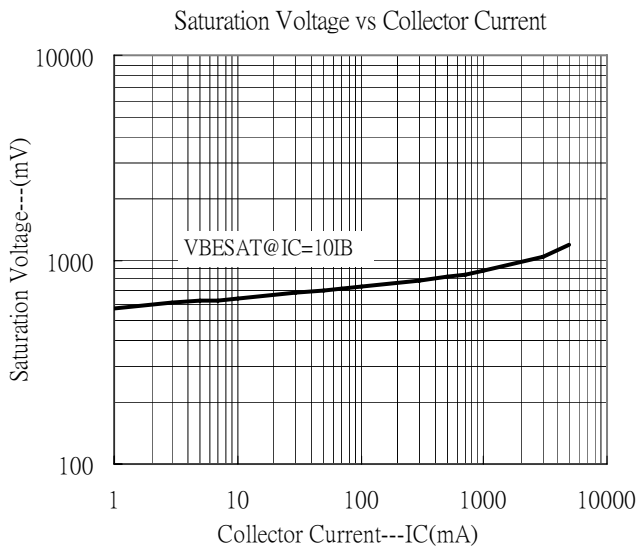

Recommended Storage Condition:

Temperature : 10~ 35 °C
 Humidity : 30~ 60% RH

Reel Dimension

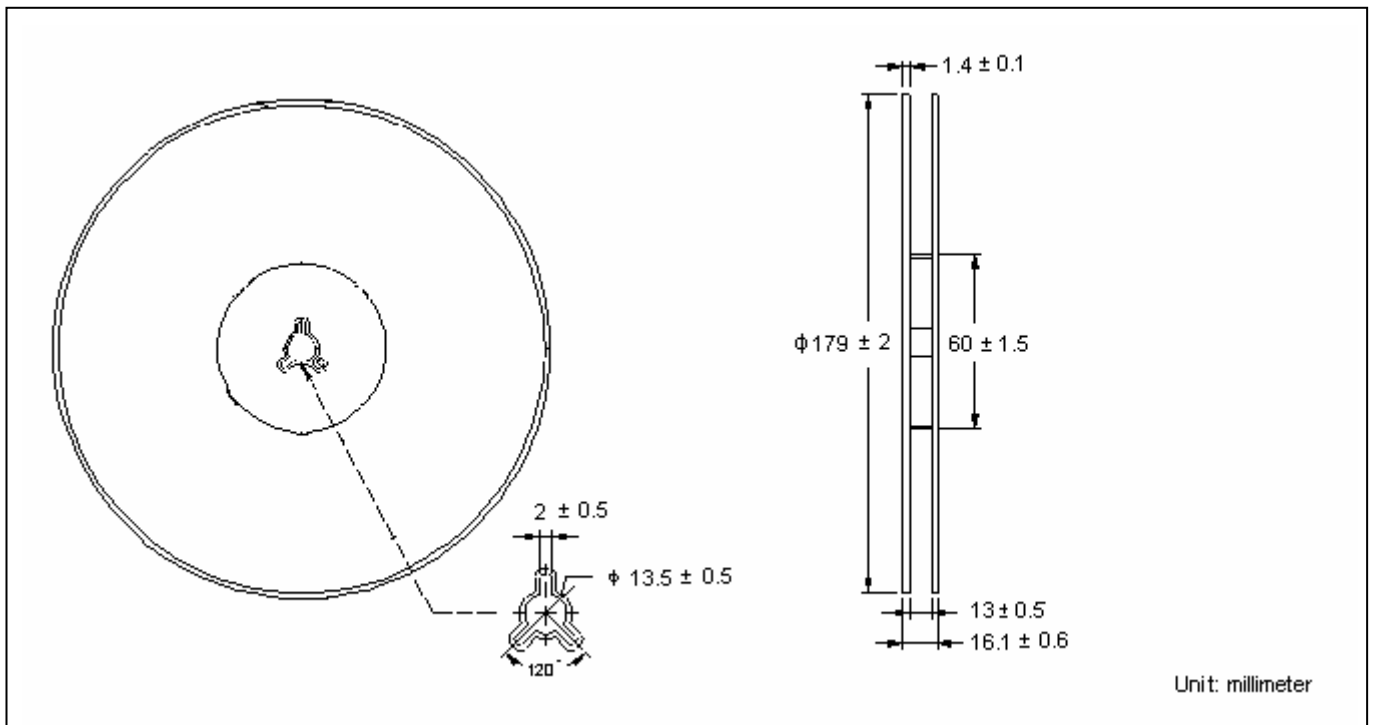

Carrier Tape Dimension

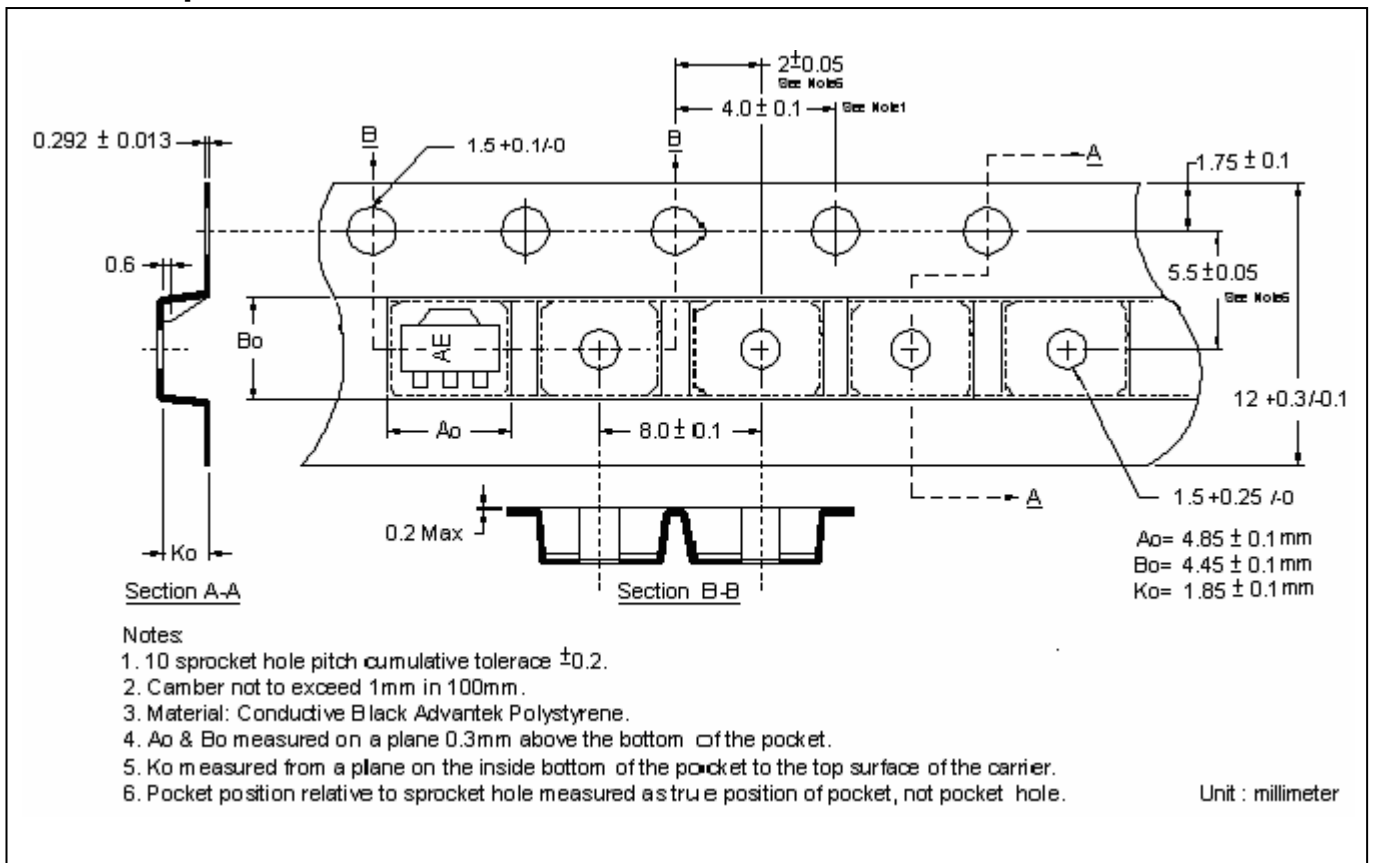

Recommended wave soldering condition

Product	Peak Temperature	Soldering Time
Pb-free devices	260 +0/-5 °C	5 +1/-1 seconds

Recommended temperature profile for IR reflow

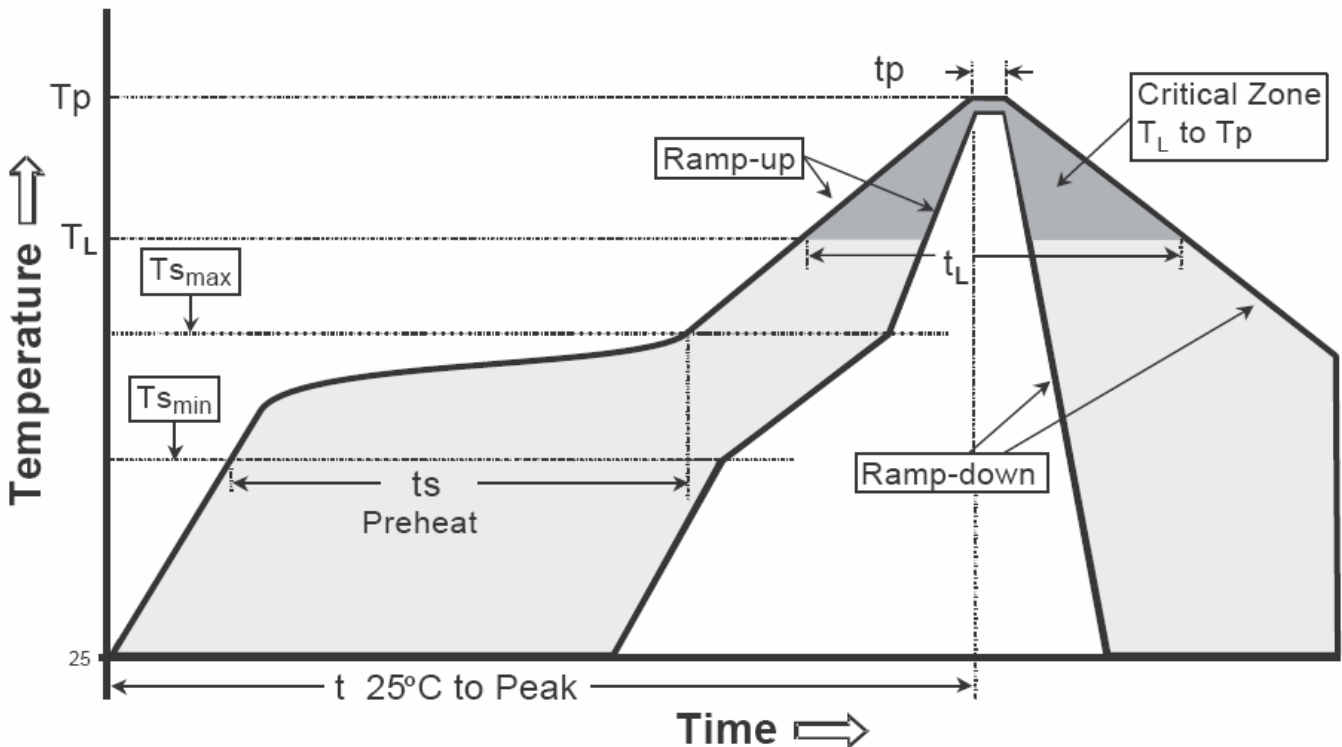

Profile feature	Sn-Pb eutectic Assembly	Pb-free Assembly
Average ramp-up rate (Tsmax to Tp)	3°C/second max.	3°C/second max.
Preheat		
-Temperature Min(Ts min)	100°C	150°C
-Temperature Max(Ts max)	150°C	200°C
-Time(ts min to ts max)	60-120 seconds	60-180 seconds
Time maintained above:		
-Temperature (TL)	183°C	217°C
- Time (tL)	60-150 seconds	60-150 seconds
Peak Temperature(Tp)	240 +0/-5 °C	260 +0/-5 °C
Time within 5°C of actual peak temperature(tp)	10-30 seconds	20-40 seconds
Ramp down rate	6°C/second max.	6°C/second max.
Time 25 °C to peak temperature	6 minutes max.	8 minutes max.

Note : All temperatures refer to topside of the package, measured on the package body surface.

SOT-89 Dimension

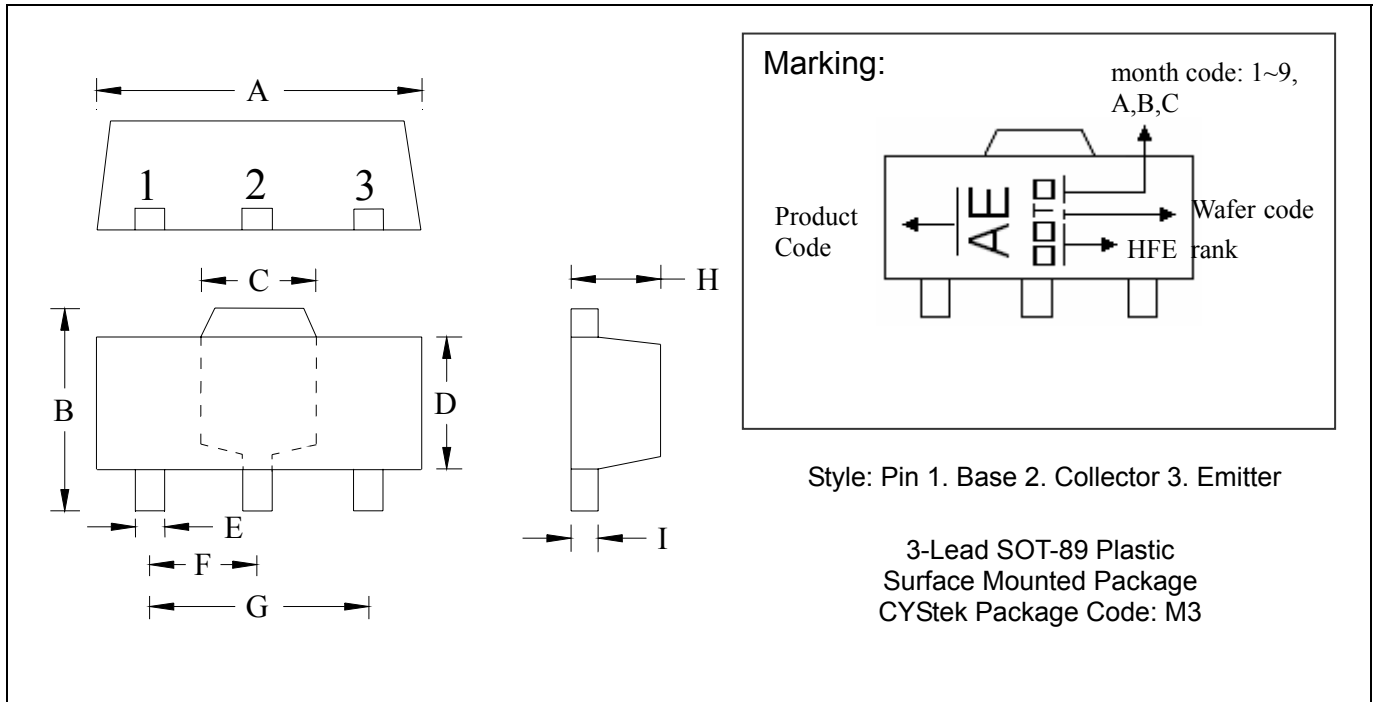

DIM	Inches		Millimeters		DIM	Inches		Millimeters	
	Min.	Max.	Min.	Max.		Min.	Max.	Min.	Max.
A	0.1732	0.1811	4.40	4.60	F	0.0591	TYP	1.50	TYP
B	0.1551	0.1673	3.94	4.25	G	0.1181	TYP	3.00	TYP
C	0.0610	REF	1.55	REF	H	0.0551	0.0630	1.40	1.60
D	0.0906	0.1024	2.30	2.60	I	0.0138	0.0173	0.35	0.44
E	0.0126	0.0205	0.32	0.52					

Notes: 1.Controlling dimension: millimeters.
 2.Maximum lead thickness includes lead finish thickness, and minimum lead thickness is the minimum thickness of base material.
 3.If there is any question with packing specification or packing method, please contact your local CYStek sales office.

Material:

- Lead: Pure tin plated.
- Mold Compound: Epoxy resin family, flammability solid burning class: UL94V-0.

Important Notice:

- All rights are reserved. Reproduction in whole or in part is prohibited without the prior written approval of CYStek.
- CYStek reserves the right to make changes to its products without notice.
- CYStek **semiconductor products are not warranted to be suitable for use in Life-Support Applications, or systems.**
- CYStek assumes no liability for any consequence of customer product design, infringement of patents, or application assistance.