

General Purpose NPN Epitaxial Planar Transistor

BTC2411N3

Description

- The BTC2411N3 is designed for using in driver stage of AF amplifier and general purpose switching application.
- High $I_{C(Max)}$, $I_{C(Max)} = 0.6A$.
- Low $V_{CE(sat)}$, Typ. $V_{CE(sat)} = 0.2V$ at $I_C/I_B = 500mA/50mA$.
 Optimal for low Voltage operation.
- Complementary to BTA1036N3.
- Pb-free lead plating and halogen-free package.
- AEC-Q101 qualified.

Symbol

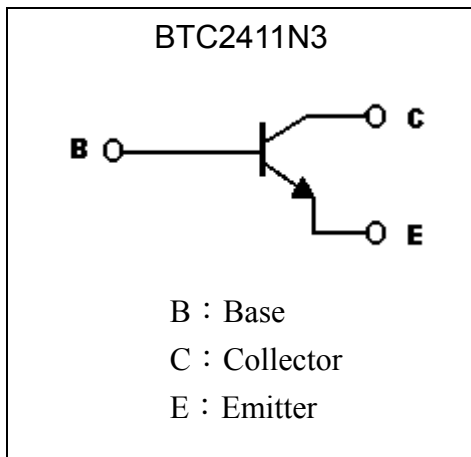

Outline

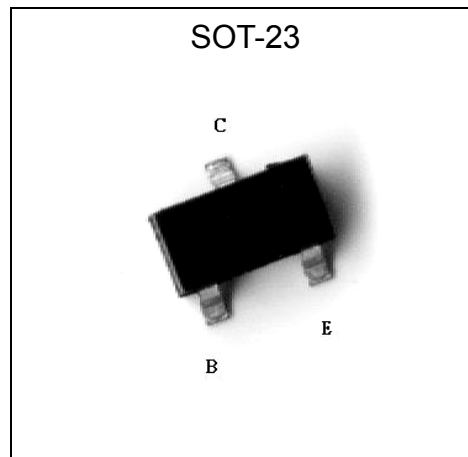

Ordering Information

Device	Package	Shipping
BTC2411N3-0-T1-G	SOT-23 (Pb-free lead plating and halogen-free package)	3000 pcs / tape & reel

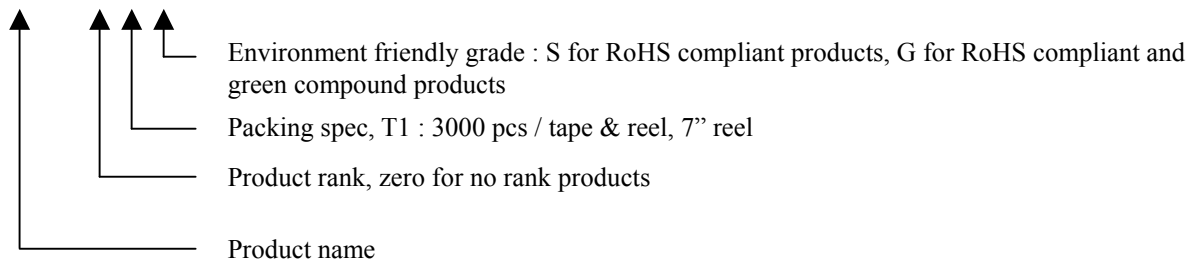



Absolute Maximum Ratings (Ta=25°C)

Parameter	Symbol	Limits	Unit
Collector-Base Voltage	V _{CBO}	75	V
Collector-Emitter Voltage	V _{CEO}	50	V
Emitter-Base Voltage	V _{EBO}	6	V
Collector Current	I _C	0.6	A
Power Dissipation (T _A =25°C)	P _D	225 (Note)	mW
Power Dissipation (T _C =25°C)	P _D	560	mW
Thermal Resistance, Junction to Ambient	R _{θJA}	556 (Note)	°C/W
Thermal Resistance, Junction to Case	R _{θJC}	223	°C/W
Operating Junction Temperature Range	T _j	-55~+150	°C
Storage Temperature	T _{stg}	-55~+150	°C

Note : Free air condition

Characteristics (Ta=25°C)

Symbol	Min.	Typ.	Max.	Unit	Test Conditions
BV _{CBO}	75	-	-	V	I _C =10μA
BV _{CEO}	50	-	-	V	I _C =10mA
BV _{EBO}	6	-	-	V	I _E =10μA
I _{CBO}	-	-	10	nA	V _{CB} =60V
I _{CEX}	-	-	10	nA	V _{CE} =60V, V _{BE} =-3V
I _{EBO}	-	-	10	nA	V _{EB} =3V
*V _{CE(sat)1}	-	-	0.5	V	I _C =380mA, I _B =10mA
*V _{CE(sat)2}	-	-	0.25	V	I _C =150mA, I _B =15mA
*V _{CE(sat)3}	-	0.2	0.45	V	I _C =500mA, I _B =50mA
*V _{BE(sat)1}	0.7	-	1.0	V	I _C =150mA, I _B =15mA
*V _{BE(sat)2}	-	-	1.2	V	I _C =500mA, I _B =50mA
*h _{FE1}	85	-	-		V _{CE} =1V, I _C =0.1mA
*h _{FE2}	90	-	-		V _{CE} =1V, I _C =1mA
*h _{FE3}	95	-	-		V _{CE} =1V, I _C =10mA
*h _{FE4}	100	-	300		V _{CE} =1V, I _C =150mA
*h _{FE5}	40	-	-		V _{CE} =2V, I _C =500mA
f _T	-	230	-	MHz	V _{CE} =5V, I _C =20mA, f=100MHz
C _{ob}	-	9.3	-	pF	V _{CB} =5V, f=1MHz

*Pulse Test: Pulse Width ≤380μs, Duty Cycle ≤2%

Recommended Storage Condition:

Temperature : ≤ 30 °C

Humidity : ≤ 60% RH



Typical Characteristics

Emitter Grounded Output Characteristics

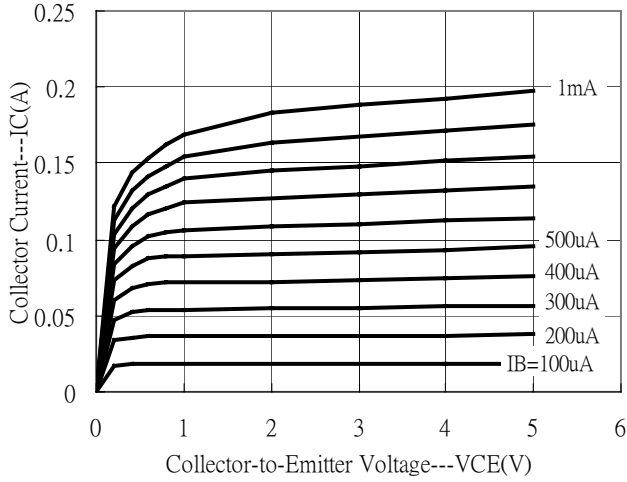

Emitter Grounded Output Characteristics

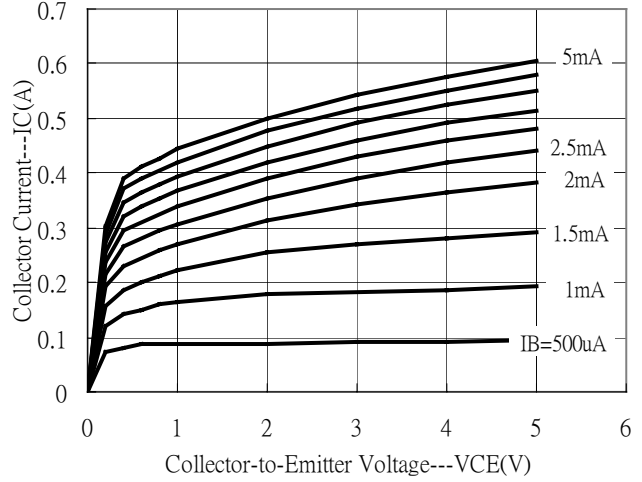

Current Gain vs Collector Current

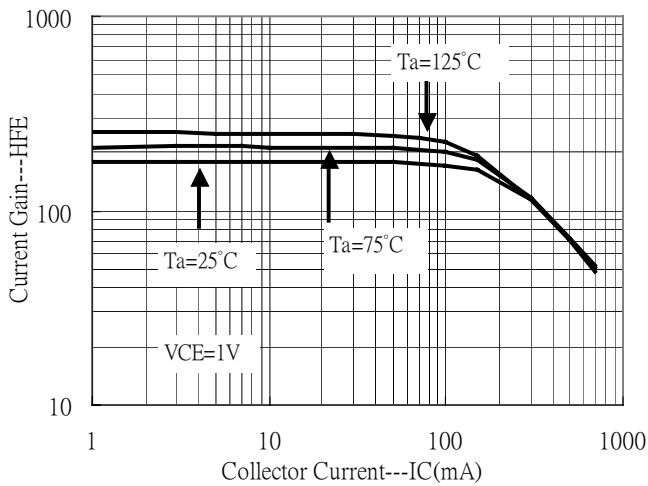

Current Gain vs Collector Current

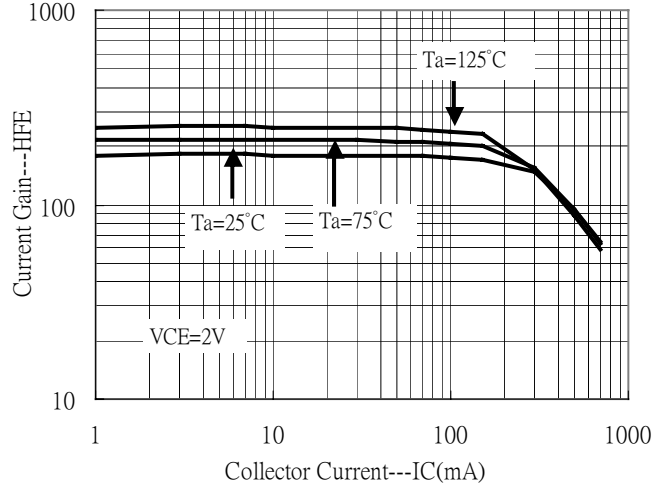

Current Gain vs Collector Current

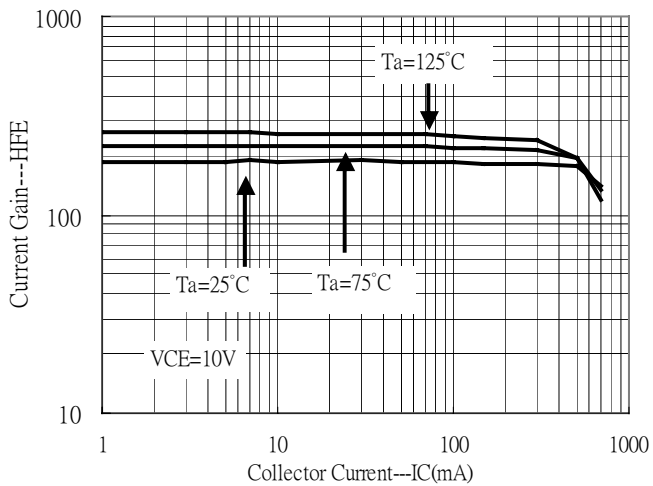

Saturation Voltage vs Collector Current

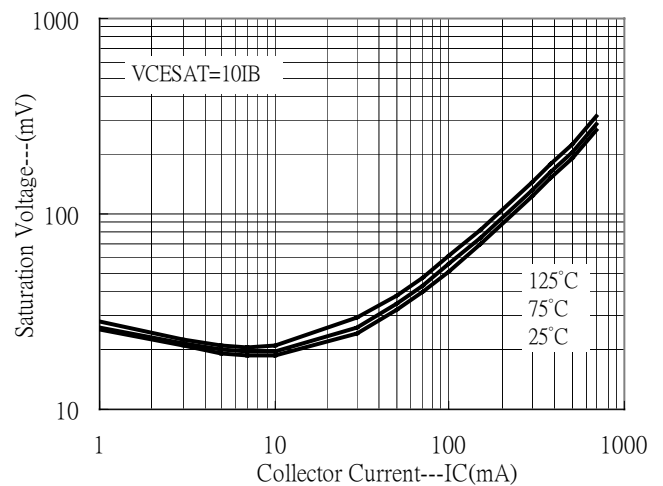

Typical Characteristics(Cont.)

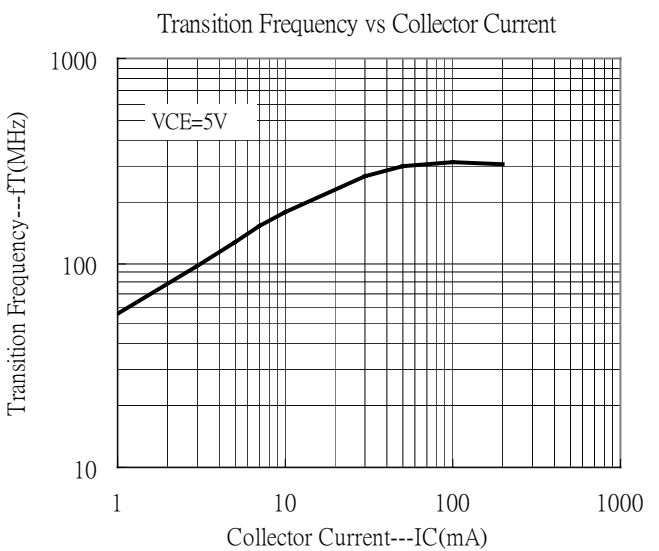
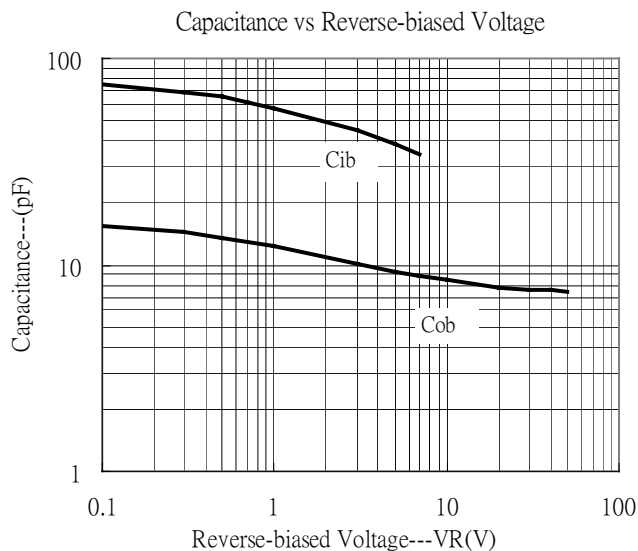
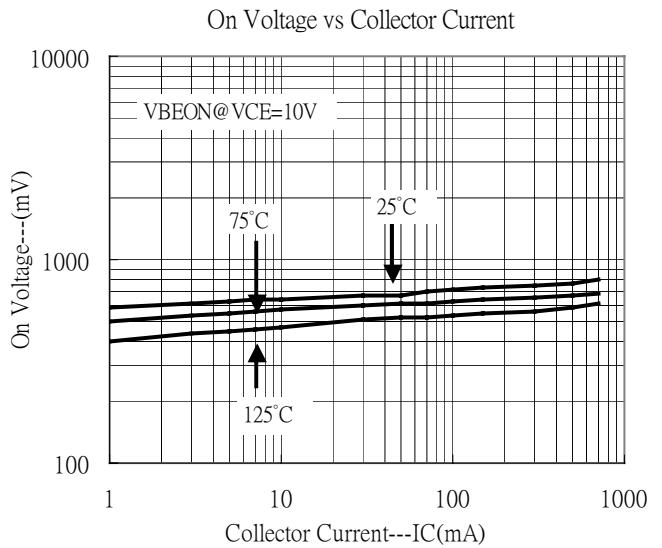
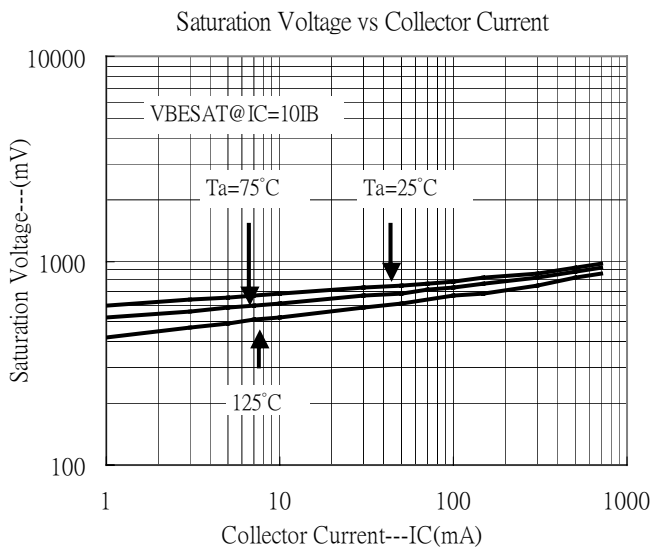
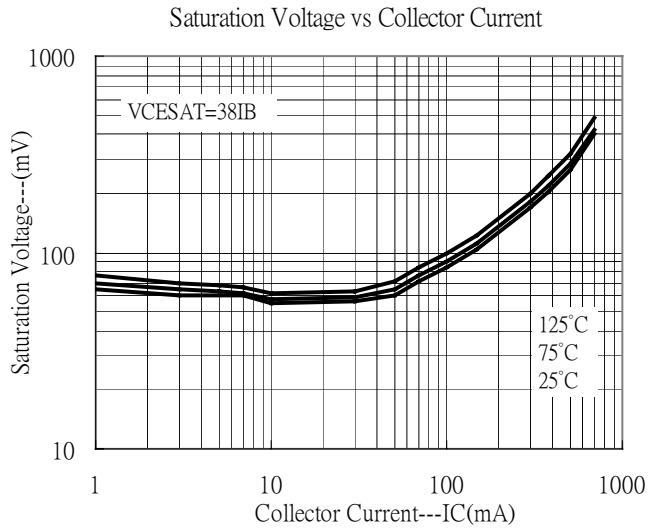
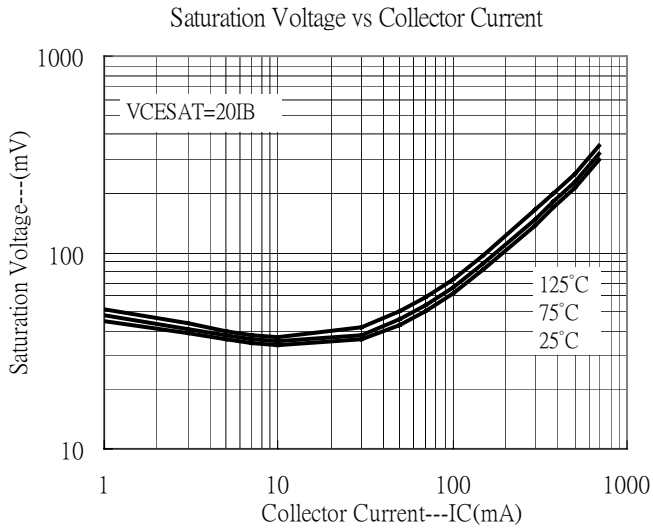

Typical Characteristics(Cont.)

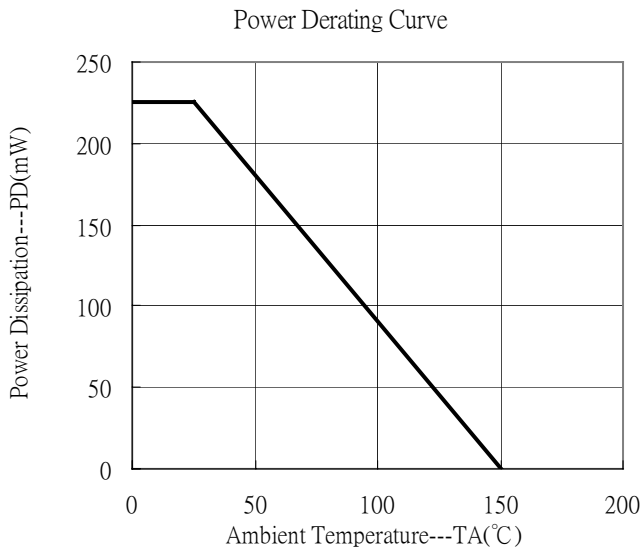

Recommended Soldering Footprint

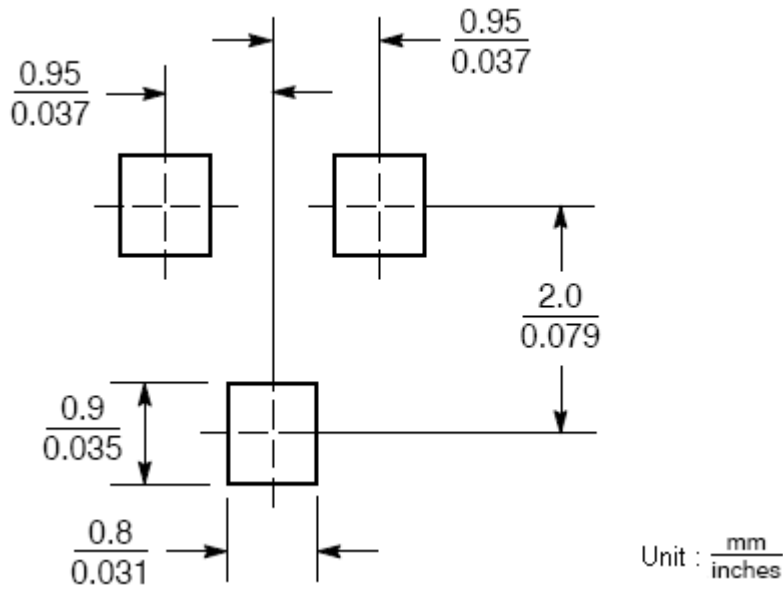

Reel Dimension

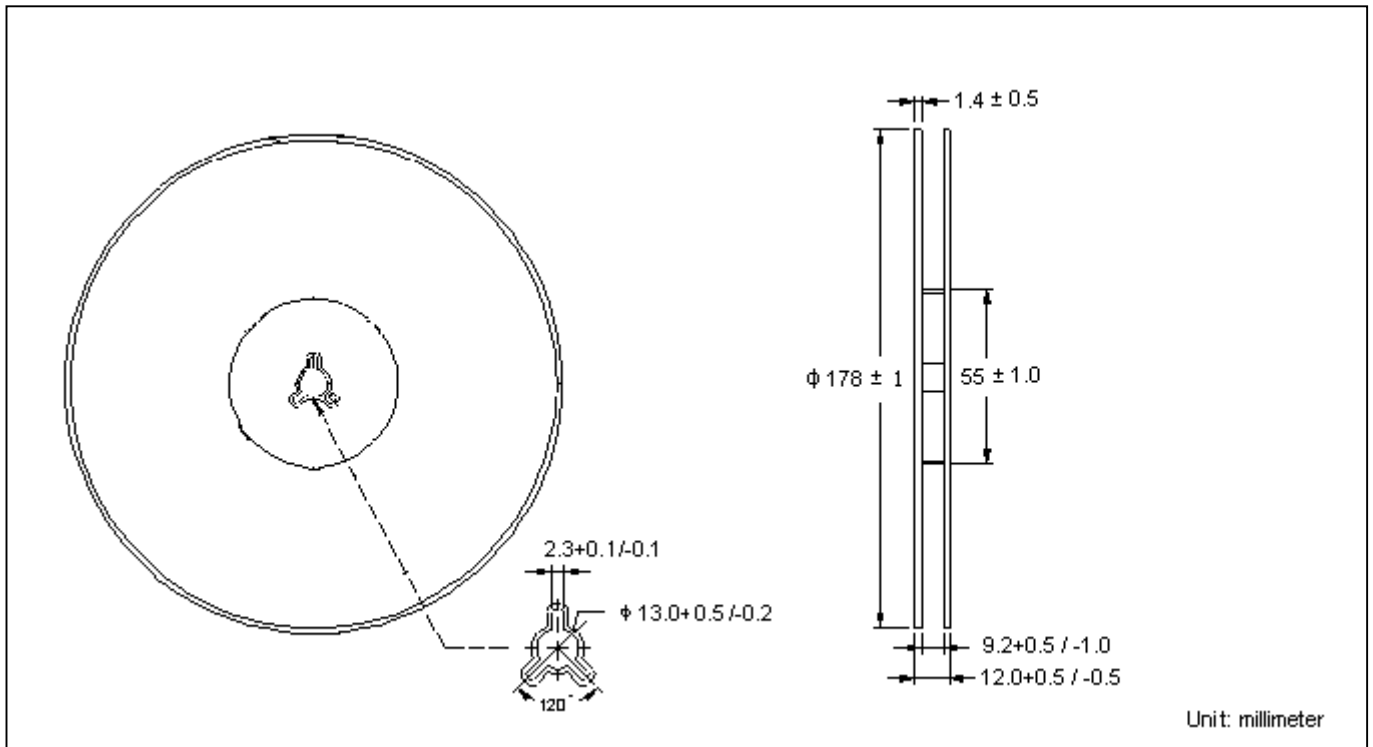

Carrier Tape Dimension

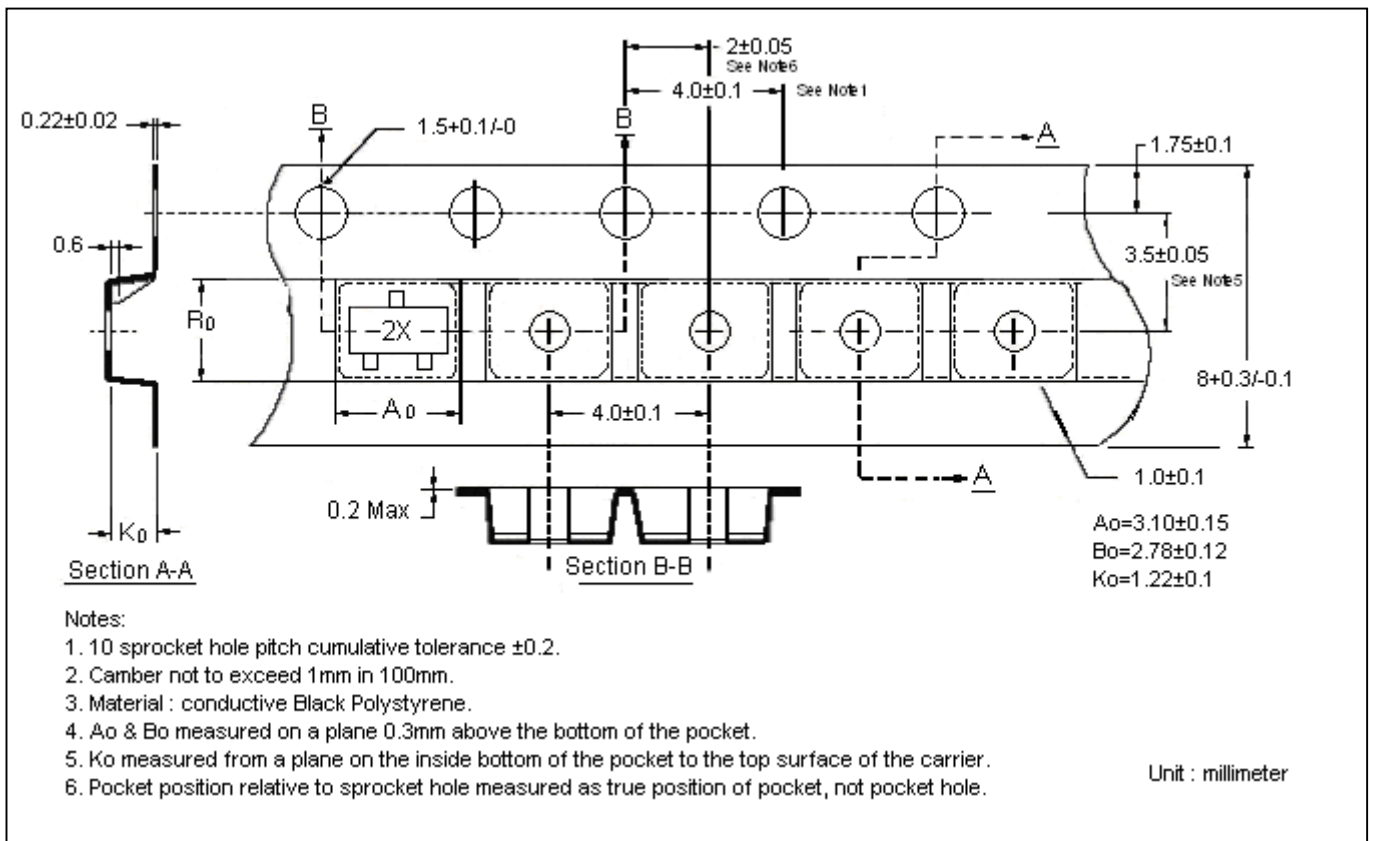

Recommended wave soldering condition

Product	Peak Temperature	Soldering Time
Pb-free devices	260 +0/-5 °C	5 +1/-1 seconds

Recommended temperature profile for IR reflow

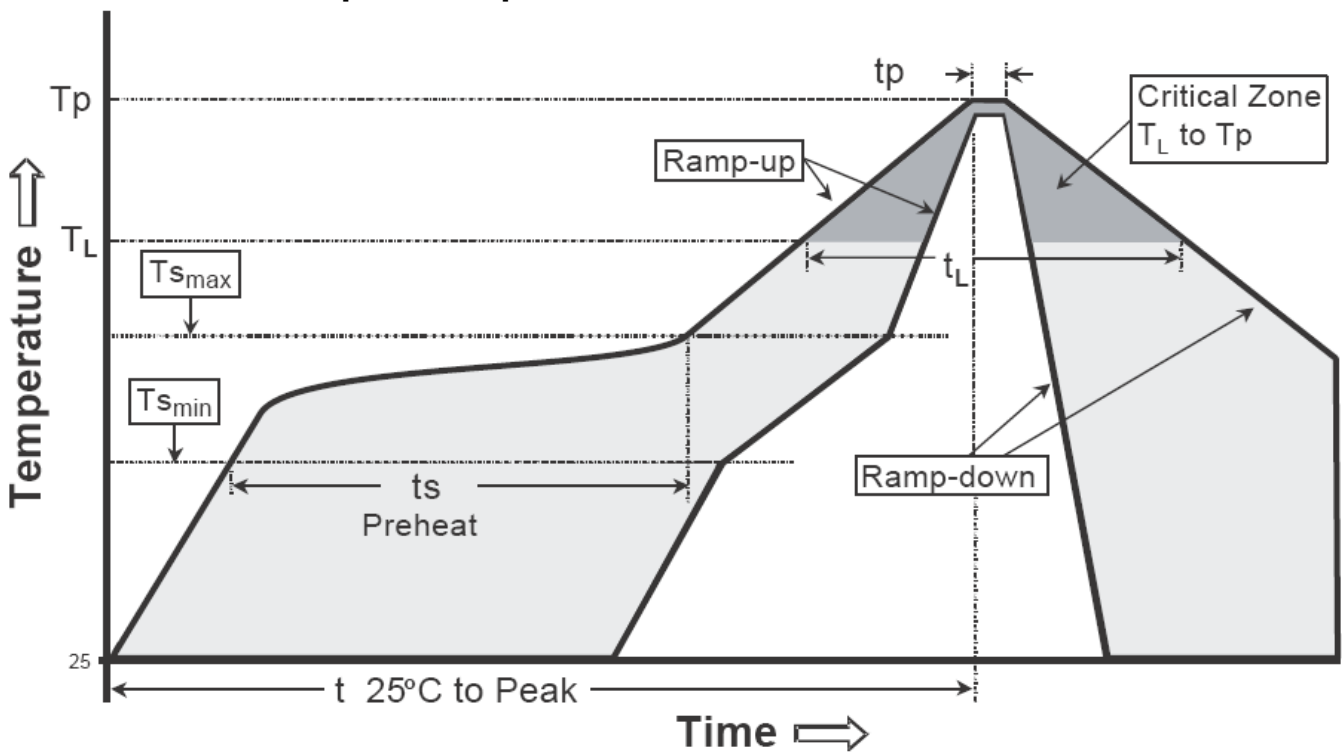

Profile feature	Sn-Pb eutectic Assembly	Pb-free Assembly
Average ramp-up rate (Tsmax to Tp)	3°C/second max.	3°C/second max.
Preheat		
-Temperature Min(Ts min)	100°C	150°C
-Temperature Max(Ts max)	150°C	200°C
-Time(ts min to ts max)	60-120 seconds	60-180 seconds
Time maintained above:		
-Temperature (TL)	183°C	217°C
- Time (tL)	60-150 seconds	60-150 seconds
Peak Temperature(TP)	240 +0/-5 °C	260 +0/-5 °C
Time within 5°C of actual peak temperature(tp)	10-30 seconds	20-40 seconds
Ramp down rate	6°C/second max.	6°C/second max.
Time 25 °C to peak temperature	6 minutes max.	8 minutes max.

Note : All temperatures refer to topside of the package, measured on the package body surface.

SOT-23 Dimension

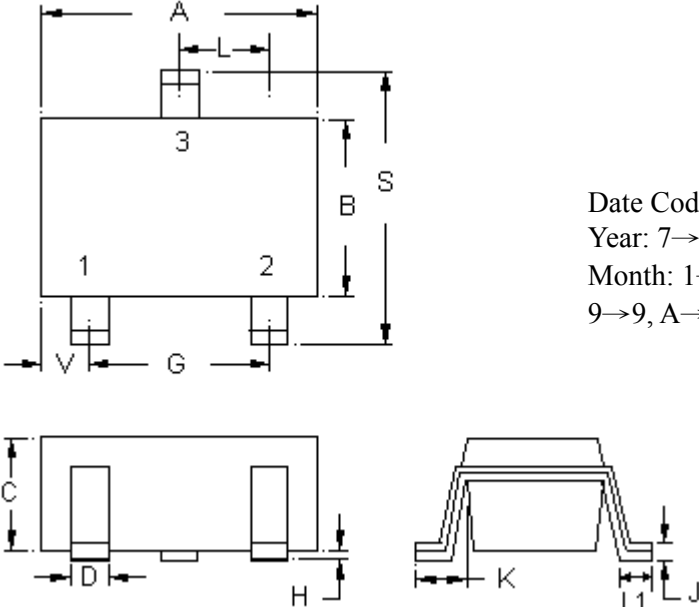

The diagram shows three views of the SOT-23 package: a top view with dimensions A, B, C, G, H, L, S, V, and pin numbers 1, 2, 3; a side view with dimensions C, D, H, J; and a perspective view with dimensions K, L1, L, J.

Marking:

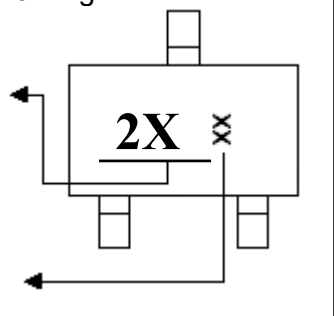

Product Code

Date Code: Year+Month
 Year: 7→2017, 8→2018
 Month: 1→1, 2→2, . . .
 9→9, A→10, B→11, C→12

3-Lead SOT-23 Plastic
 Surface Mounted Package
 CYStek Package Code: N3

Style : Pin 1.Base 2.Emitter 3.Collector

DIM	Inches		Millimeters		DIM	Inches		Millimeters	
	Min.	Max.	Min.	Max.		Min.	Max.	Min.	Max.
A	0.1102	0.1204	2.80	3.04	J	0.0032	0.0079	0.08	0.20
B	0.0472	0.0551	1.20	1.40	K	0.0118	0.0266	0.30	0.67
C	0.0335	0.0512	0.89	1.30	L	0.0335	0.0453	0.85	1.15
D	0.0118	0.0197	0.30	0.50	S	0.0830	0.1004	2.10	2.55
G	0.0669	0.0910	1.70	2.30	V	0.0098	0.0256	0.25	0.65
H	0.0000	0.0040	0.00	0.10	L1	0.0118	0.0197	0.30	0.50

Notes: 1.Controlling dimension: millimeters.
 2.Maximum lead thickness includes lead finish thickness, and minimum lead thickness is the minimum thickness of base material.
 3.If there is any question with packing specification or packing method, please contact your local CYStek sales office.

Material:

- Lead: Pure tin plated.
- Mold Compound: Epoxy resin family, flammability solid burning class: UL94V-0

Important Notice:

- All rights are reserved. Reproduction in whole or in part is prohibited without the prior written approval of CYStek.
- CYStek reserves the right to make changes to its products without notice.
- CYStek **semiconductor products are not warranted to be suitable for use in Life-Support Applications, or systems.**
- CYStek assumes no liability for any consequence of customer product design, infringement of patents, or application assistance.