

**General Purpose NPN Epitaxial Planar Transistor**

# BTC4061N3

## Description

- High breakdown voltage.
- Low collector output capacitance.
- Ideal for chroma circuit.
- Pb-free lead plating and halogen-free package package.

## Symbol

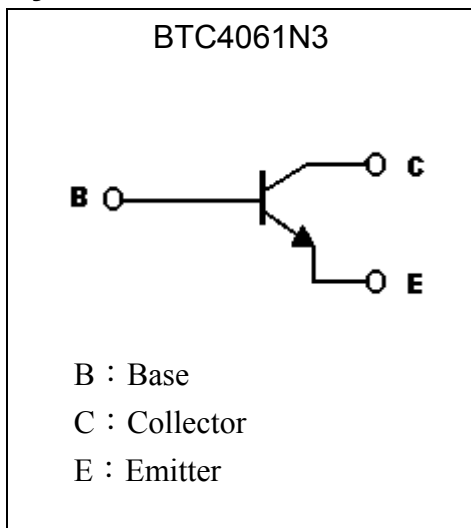

## Outline

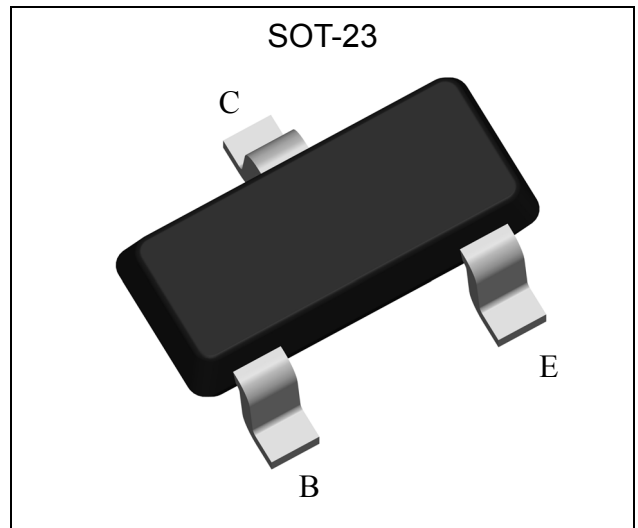

## Ordering Information

Device	Package	Shipping
BTC4061N3-X-T1-G	SOT-23 (Pb-free lead plating and halogen-free package)	3000 pcs / tape & reel

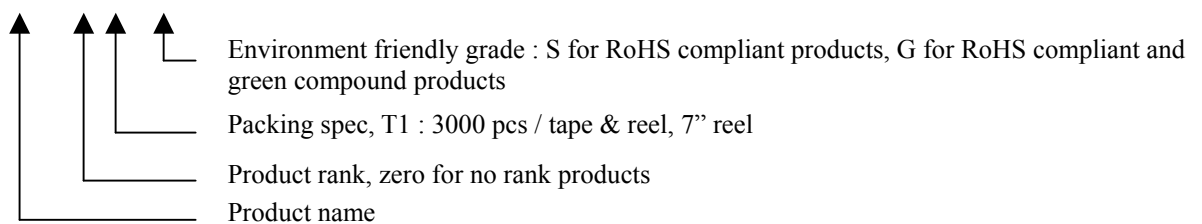

**Absolute Maximum Ratings** (Ta=25°C)

Parameter	Symbol	Limits	Unit
Collector-Base Voltage	V <sub>CB0</sub>	300	V
Collector-Emitter Voltage	V <sub>CEO</sub>	300	V
Emitter-Base Voltage	V <sub>EB0</sub>	6	V
Collector Current	I <sub>C</sub>	500	mA
Power Dissipation	P <sub>d</sub>	225	mW
Junction Temperature	T <sub>j</sub>	150	°C
Storage Temperature	T <sub>stg</sub>	-55~+150	°C

**Thermal Data**

Parameter	Symbol	Value	Unit
Thermal Resistance, Junction-to-case, max	R <sub>th,j-c</sub>	175	°C/W
Thermal Resistance, Junction-to-ambient, max	R <sub>th,j-a</sub>	556	

**Characteristics (Ta=25°C)**

Symbol	Min.	Typ.	Max.	Unit	Test Conditions
BV <sub>CB0</sub>	300	-	-	V	I <sub>C</sub> =100μA
BV <sub>CEO</sub>	300	-	-	V	I <sub>C</sub> =1mA
BV <sub>EB0</sub>	6	-	-	V	I <sub>E</sub> =10μA
I <sub>CB0</sub>	-	-	50	nA	V <sub>CB</sub> =250V
I <sub>EB0</sub>	-	-	50	nA	V <sub>EB</sub> =5V
*V <sub>CE(sat)</sub>	-	0.15	0.35	V	I <sub>C</sub> =20mA, I <sub>B</sub> =2mA
*V <sub>BE(sat)</sub>	-	-	0.9	V	I <sub>C</sub> =20mA, I <sub>B</sub> =2mA
*h <sub>FE1</sub>	90	-	-	-	V <sub>CE</sub> =10V, I <sub>C</sub> =1mA
*h <sub>FE2</sub>	100	-	270	-	V <sub>CE</sub> =10V, I <sub>C</sub> =10mA
*h <sub>FE3</sub>	40	-	-	-	V <sub>CE</sub> =10V, I <sub>C</sub> =30mA
f <sub>T</sub>	50	-	-	MHz	V <sub>CE</sub> =20V, I <sub>C</sub> =10mA, f=20MHz
C <sub>ob</sub>	-	-	6	pF	V <sub>CB</sub> =20V, f=1MHz

\*Pulse Test: Pulse Width ≤380μs, Duty Cycle≤2%

**Classification Of h<sub>FE</sub> 2**

Rank	P	Q
Range	100~180	120~270

**Typical Characteristics**

Current Gain vs Collector Current

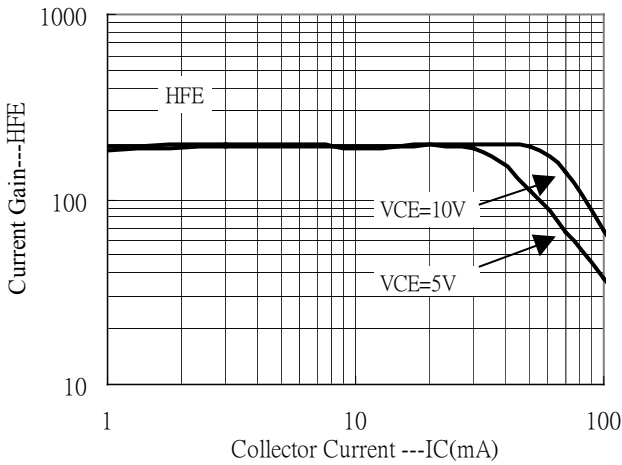

Saturation Voltage vs Collector Current

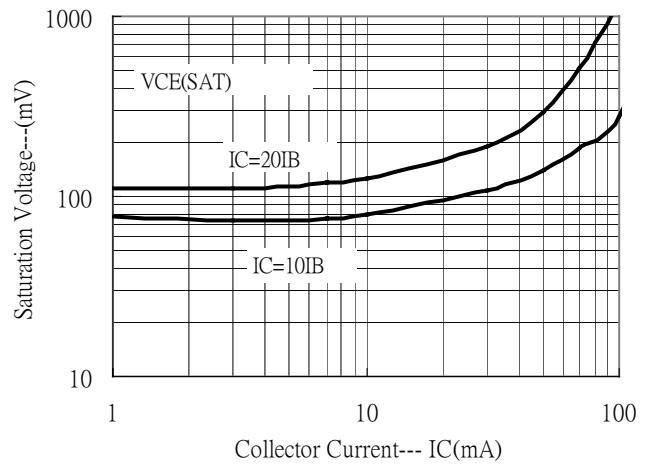

Saturation Voltage vs Collector Current

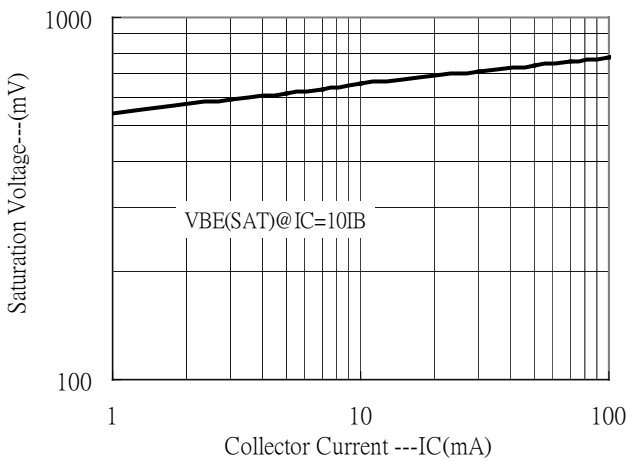

Cutoff Frequency vs Collector Current

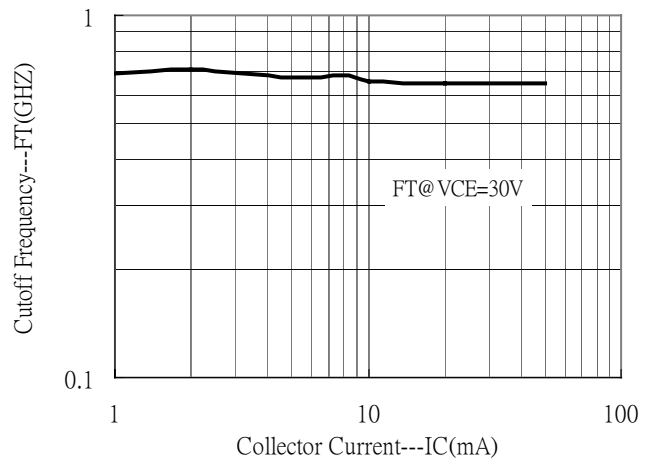

Power Derating Curve

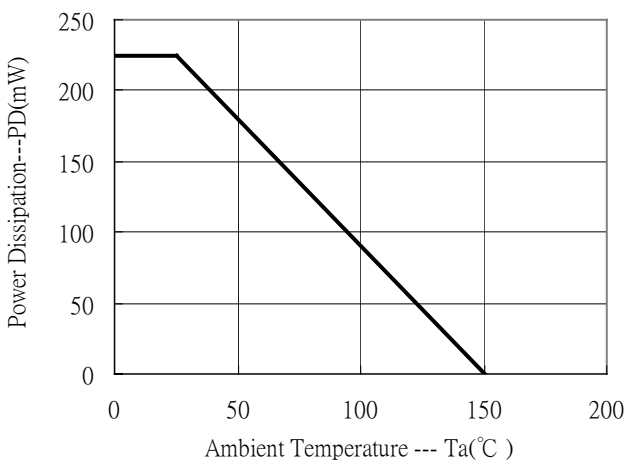

Safe Operating Area

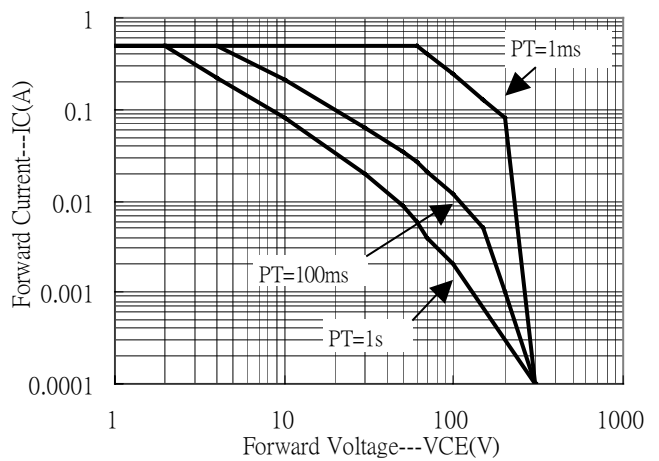

**Reel Dimension**

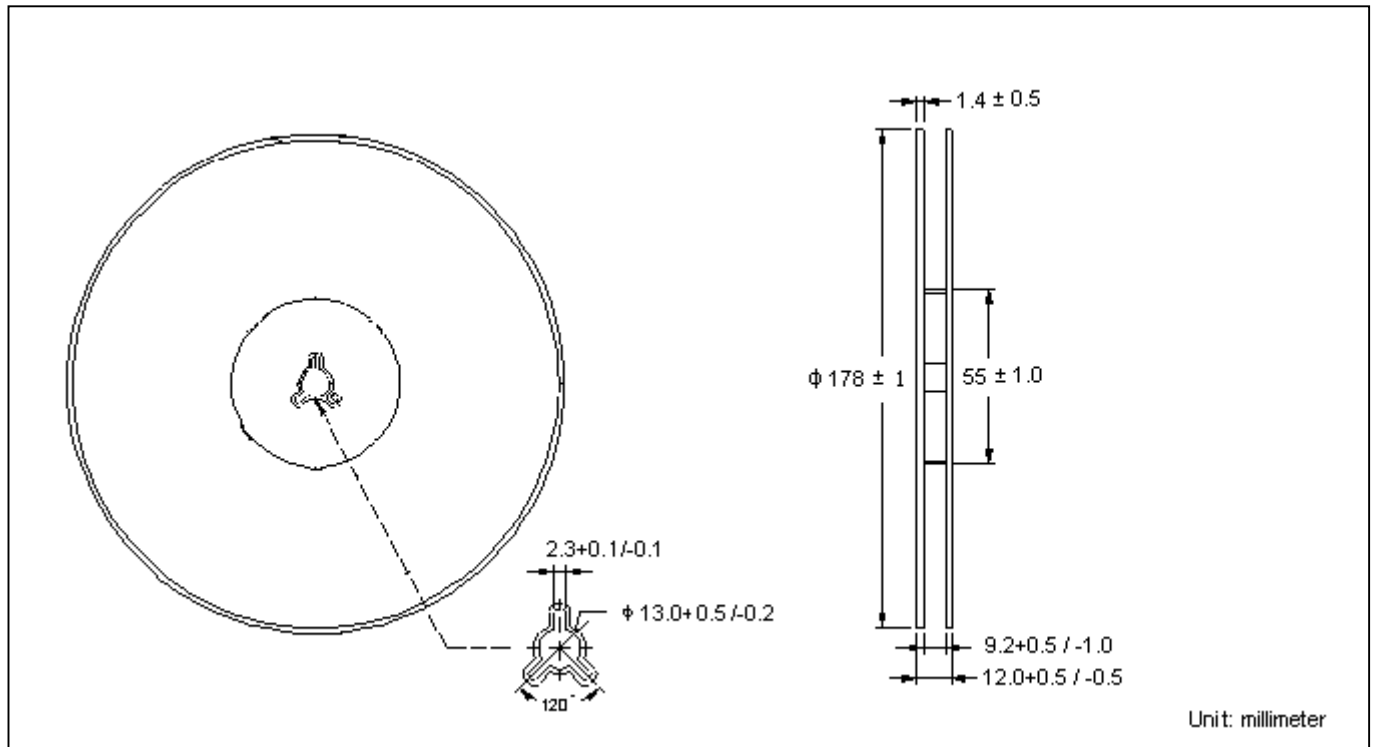

**Carrier Tape Dimension**

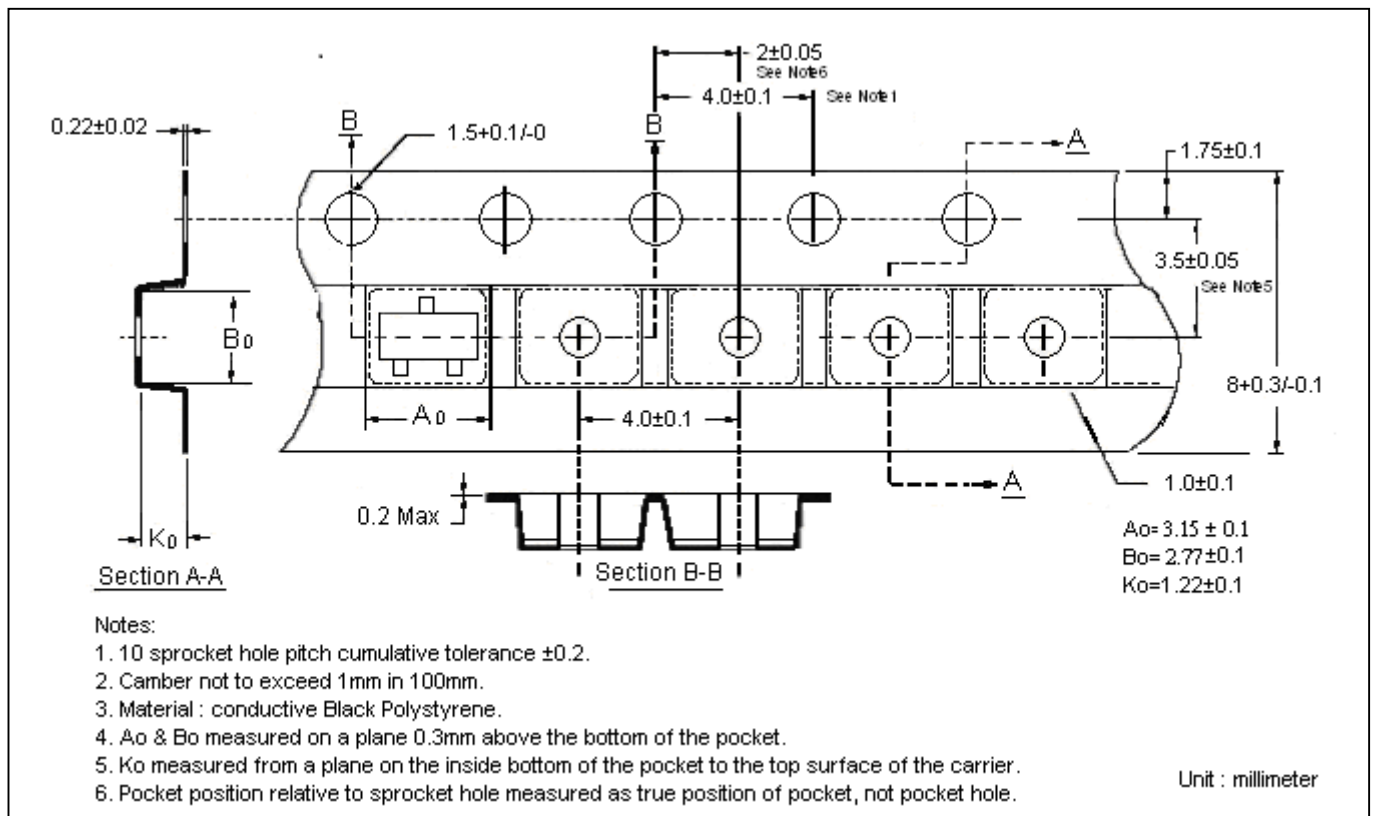



**Recommended Soldering Footprint**

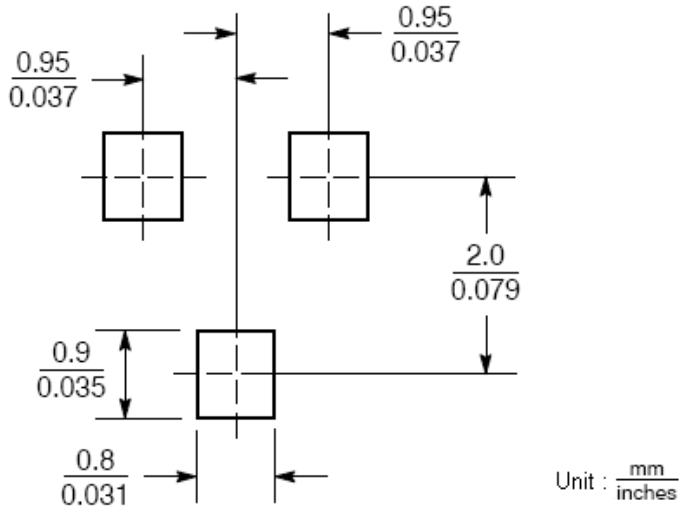

**Recommended wave soldering condition**

Product	Peak Temperature	Soldering Time
Pb-free devices	260 +0/-5 °C	5 +1/-1 seconds

**Recommended temperature profile for IR reflow**

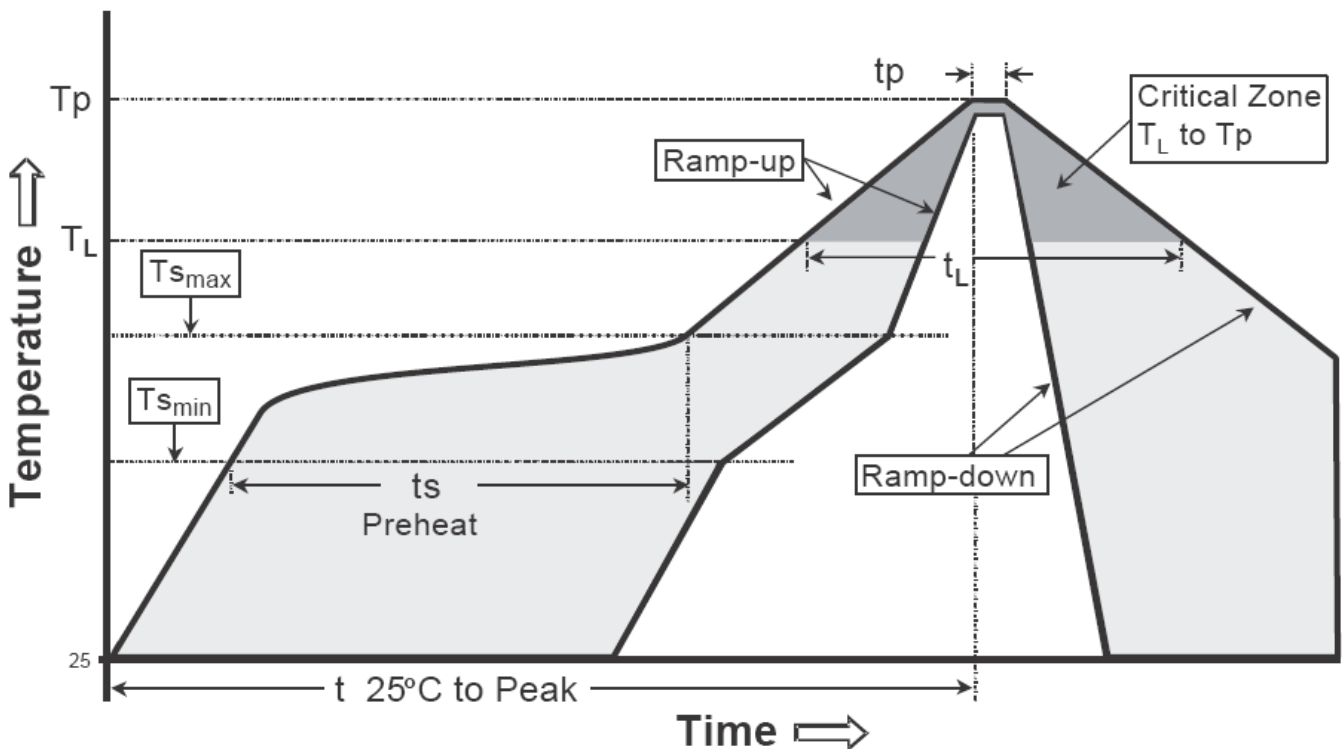

Profile feature	Sn-Pb eutectic Assembly	Pb-free Assembly
Average ramp-up rate (Tsmmax to Tp)	3°C/second max.	3°C/second max.
Preheat		
-Temperature Min(Ts min)	100°C	150°C
-Temperature Max(Ts max)	150°C	200°C
-Time(ts min to ts max)	60-120 seconds	60-180 seconds
Time maintained above:		
-Temperature (Tl)	183°C	217°C
- Time (tl)	60-150 seconds	60-150 seconds
Peak Temperature(Tp)	240 +0/-5 °C	260 +0/-5 °C
Time within 5°C of actual peak temperature(tp)	10-30 seconds	20-40 seconds
Ramp down rate	6°C/second max.	6°C/second max.
Time 25 °C to peak temperature	6 minutes max.	8 minutes max.

Note : All temperatures refer to topside of the package, measured on the package body surface.

**SOT-23 Dimension**

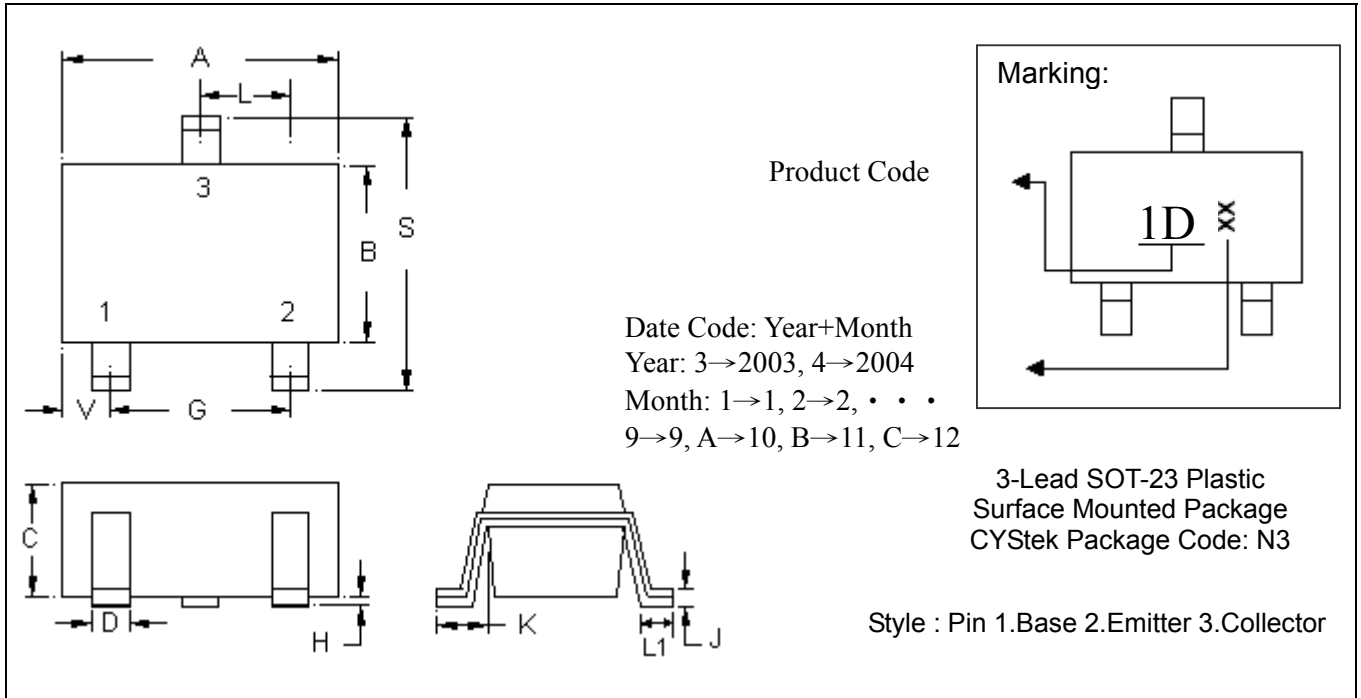

\*:Typical

DIM	Inches		Millimeters		DIM	Inches		Millimeters	
	Min.	Max.	Min.	Max.		Min.	Max.	Min.	Max.
A	0.1102	0.1204	2.80	3.04	J	0.0032	0.0079	0.08	0.20
B	0.0472	0.0551	1.20	1.40	K	0.0118	0.0266	0.30	0.67
C	0.0335	0.0512	0.89	1.30	L	0.0335	0.0453	0.85	1.15
D	0.0118	0.0197	0.30	0.50	S	0.0830	0.1004	2.10	2.55
G	0.0669	0.0910	1.70	2.30	V	0.0098	0.0256	0.25	0.65
H	0.0000	0.0040	0.00	0.10	L1	0.0118	0.0197	0.30	0.50

Notes : 1.Controlling dimension : millimeters.  
 2.Maximum lead thickness includes lead finish thickness, and minimum lead thickness is the minimum thickness of base material.  
 3.If there is any question with packing specification or packing method, please contact your local CYStek sales office.

**Material :**

- Lead : Pure tin plated..
- Mold Compound : Epoxy resin family, flammability solid burning class:UL94V-0.

**Important Notice:**

- All rights are reserved. Reproduction in whole or in part is prohibited without the prior written approval of CYStek.
- CYStek reserves the right to make changes to its products without notice.
- CYStek **semiconductor products are not warranted to be suitable for use in Life-Support Applications, or systems.**
- CYStek assumes no liability for any consequence of customer product design, infringement of patents, or application assistance.