

SUPER FLUX LED

BTF-57BLCS-XX-X

Product Features

- Ultra Bright Blue Color
- High Light Output
- 5mm Super Flux Package
- Water Clear Lens
- Highly Reliable
- IC Compatible
- Leads with Stand Off

Package Dimension

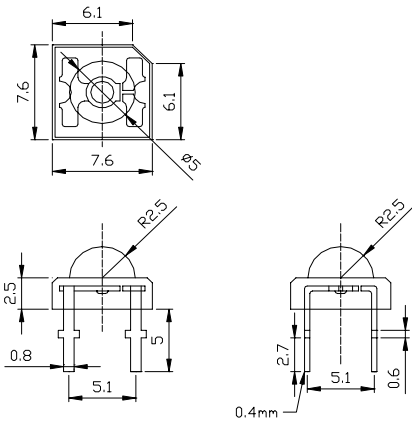

Applications

- Outdoor Sign Board
- Automotive
- Front Panel Indicator
- Special Lighting
- General Purpose LEDs



WARNING

This range of LEDs is produced with die having a high radiant flux. Care must be taken when viewing the product at close range as the light may be intense enough to cause damage to the human eye.

Note: Industry standard procedures regarding static must be observed when handling this product.

Tolerance: $\pm \frac{\text{inch}}{\text{mm}}$ Unit: $\pm \frac{0.01}{0.25}$

Optical and Electrical Characteristics at $T_a=25$

Parameter	Symbol	Minimum	Typical	Maximum	Units	Conditions
Luminous Intensity	I_v	3500	5000	-	mcd	$I_F = 20\text{mA}$ (Note 1)
Viewing Angle	$2\theta_{1/2}$	-	90	-	degree	$I_F = 20\text{mA}$
Peak Wavelength	λ_P	460	-	470	nm	$I_F = 20\text{mA}$ (Note 2)
DC Forward Voltage	V_F	-	3.5	4.0	V	$I_F = 20\text{mA}$
DC Reverse Current	I_R	0	-	10	μA	$V_R=5\text{V}$

Notes:

1. Light intensity measures the light sensing response standard using chromatic meter. Refer to the CIE eye-response curve set by International Lighting committee. Tolerance of minimum and maximum intensity = $\pm 15\%$
2. Color coordinates range can be selected from the bin selection table. The parameters used fulfilled the 1932 2 standard
3. These products are sensitive to static electricity and care must be fully taken when handling products



SUPER FLUX LED

BTF-57BLCS-XX-X

Absolute Maximum Ratings at $T_a=25$

Symbol	Parameter	Max.	Unit
P_D	Power Rating	80	mW
V_R	Reverse Voltage ($I_R=10\mu A$)	5	V
I_F	Continuous Forward Current	30	mA
I_{PF}	Peak Forward Current (0.1 duty cycle @ 1kHz)	100	mA
T_{opr}	Operating Temperature Range	-35 ~ + 80	
T_{stg}	Storage Temperature Range	-40 ~ + 100	
Lead Soldering Temperature [1.6mm (0.063inch) from body]		260	- max 5 seconds

Color and Brightness Selection

BTF-57BLCS-XX-X

Color Bin Selection

Bin	Blue (nm)
B5	460~465
B6	465~470
XX	460~470

Brightness Bin Selection

Bin	Range(mcd)
T	3500~4900
U	4900~6900