

# SUPER FLUX LED

## BTF-57NRCS-XX-X

### Product Features

- Ultra Bright Normal Red Color
- High Light Output
- 5mm Super Flux Package
- Water Clear Lens
- Highly Reliable
- IC Compatible
- Leads with Stand Off

### Package Dimension

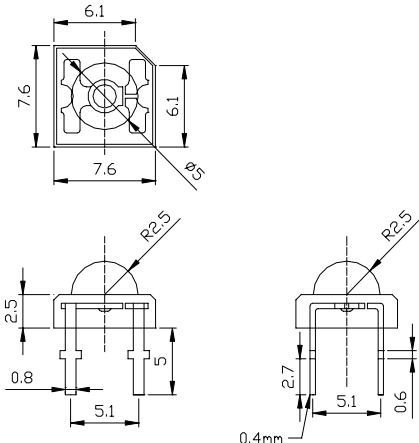

### Applications

- Outdoor Sign Board
- Automotive
- Front Panel Indicator
- Special Lighting
- General Purpose LEDs



#### WARNING

This range of LEDs is produced with die having a high radiant flux. Care must be taken when viewing the product at close range as the light may be intense enough to cause damage to the human eye.

**Note:** Industry standard procedures regarding static must be observed when handling this product.

Tolerance:  $\pm \frac{\text{inch}}{\text{mm}}$  Unit:  $\pm \frac{0.01}{0.25}$

### Optical and Electrical Characteristics at $T_a=25$

Parameter	Symbol	Minimum	Typical	Maximum	Units	Conditions
Luminous Intensity	$I_v$	485	800	-	mcd	$I_F = 20\text{mA}$ (Note 1)
Viewing Angle	$2\theta_{1/2}$	-	90	-	degree	$I_F = 20\text{mA}$
Peak Wavelength	$\lambda_P$	620	-	630	nm	$I_F = 20\text{mA}$ (Note 2)
DC Forward Voltage	$V_F$	-	1.9	2.5	V	$I_F = 20\text{mA}$
DC Reverse Current	$I_R$	0	-	10	$\mu\text{A}$	$V_R=5\text{V}$

#### Notes:

1. Light intensity measures the light sensing response standard using chromatic meter. Refer to the CIE eye-response curve set by International Lighting committee. Tolerance of minimum and maximum intensity =  $\pm 15\%$
2. Color coordinates range can be selected from the bin selection table. The parameters used fulfilled the 1932 2 standard
3. These products are sensitive to static electricity and care must be fully taken when handling products



## SUPER FLUX LED

### BTF-57NRCS-XX-X

Absolute Maximum Ratings at  $T_a=25$

Symbol	Parameter	Max.	Unit
$P_D$	Power Rating	60	mW
$V_R$	Reverse Voltage ( $I_R=10\mu A$ )	5	V
$I_F$	Continuous Forward Current	30	mA
$I_{PF}$	Peak Forward Current (0.1 duty cycle @ 1kHz)	100	mA
$T_{opr}$	Operating Temperature Range	-35 ~ + 80	
$T_{stg}$	Storage Temperature Range	-40 ~ + 100	
Lead Soldering Temperature [1.6mm (0.063inch) from body]		260	- max 5 seconds

Color and Brightness Selection

### BTF-57NRCS-XX-X

#### Color Bin Selection

Bin	Normal Red (nm)
O1	620~625
O2	625~630
XX	620~630

#### Brightness Bin Selection

Bin	Range(mcd)
N	485~680
O	680~950
P	950~1300