

BTM222B-X Datasheet



BTM222B-A Datasheet



BTM222B-AC Datasheet



BTM222B-AC-KIT Datasheet

The BTM-222B-X is a small form factor, low power, simple to integrate Bluetooth radio for OEMs adding wireless capability BTM-222B-X to their products. The is perfect for battery powered applications and by default is ready to use in the SPP (Serial Port Profile) configuration. It uses only 250 uA in sleep mode while still being discoverable and connectable. Multiple low power modes available allow you to dial in the lowest power profile for your application. The BTM-222B-X supports multiple Bluetooth profiles, is fully certified, and is simple to design in, making it a complete embedded Bluetooth solution. With its high performance on-chip antenna and support for Bluetooth Enhanced Data Rate (EDR), the BTM-222B-X delivers up to 3 Mbps data rate for distances to 100 meters. The BTM-222B-X is the perfect product for engineers adding Bluetooth capability to their product without spending significant time and money to develop Bluetooth specific hardware and software.

The BTM-222B-X can be configured in different modes:

HCI Mode: In this mode the Bluetooth stack is running on an external processor (not on BTM-222)

There are two possible hardware interface options:

UART: This is called HCI over H4. The external processor running the stack is interfaced to the BTM-222B-X using the UART interface. The baud rate at which the BTM-222B-X talks to the processor is fixed and needs to be programmed (in the BTM-222) during the firmware flash process. Customers need to specify this while ordering.

USB: In this mode, the BTM-222B-X is interfaced to the external processor using a USB interface. The BTM-222B-X acts as a USB slave (not a USB host). The key advantage of HCI mode is that it allows customers to run custom profiles on their processor. It also provides fast data rates (up to 3 Mbps).

Application

- Access point
- Domestic and Industrial applications
- Personal Digital Assistants(PDA)
- Serial Adapter
- GPS, POS, Barcode Reader
- Digital camera, Printer & Cellular phone
- Cordless handset

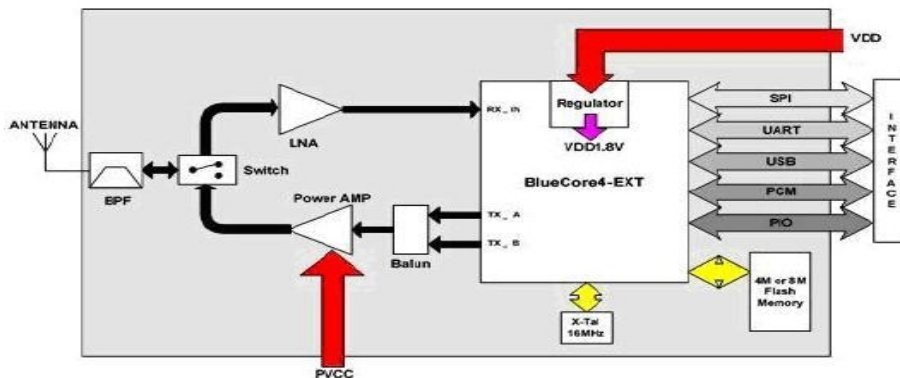

Electrical Characteristics

Absolute Maximum Ratings					
Parameter	Min.	Max.	Unit		
Storage Temperature	-40	+150	°C		
Supply Voltage(VDD)	2.7	3.6	DCV		
Supply Voltage(PVCC)	3.0	3.3	DCV		
Other Pin Voltage	Vss-0.4	VDD+0.4	DCV		
Recommended Operating Conditions					
Parameter	Min.	Max.	Unit		
Temperature	-20	+75	°C		
Supply Voltage for UART	3.0	3.6	DCV		
Supply Voltage for USB	3.0	3.6	DCV		
General Electrical Specification					
Parameter	Description	Min.	Typ.	Max.	Unit
Carrier Frequency		2.402		2.480	GHz
RF Output Power	Measured in 50ohm	15	16.5	18	dBm
RX sensitivity		-	-88	-86	dBm
Load Impedance	No abnormal Oscillation			5:1	
Input Low Voltage	RESET,UART,GPIO,PCM	-0.30	-	0.80	DCV
Input High Voltage	RESET,UART,GPIO,PCM	0.7VDD	-	VDD+0.3	DCV
Output Low Voltage	UART,GPIO,PCM	-	-	0.40	DCV
Output High Voltage	UART,GPIO,PCM	VDD-0.4	-	-	DCV
Average Current Consumption	Receive DM1		114		mA

Radio Characteristics - Basic Data Rate

Transmitter , VDD = 3.3V Temperature =+20°C						
	Frequency (GHz)	Min.	Typ.	Max.	Bluetooth Specification	Unit
RF transmit power	2.402	16	17.5	18.5	-6 to +20	dBm
	2.441	16	17.5	18.5		dBm
	2.480	16	17.5	18.5		dBm
Initial carrier frequency tolerance	2.402	-	12	25	±75	kHz
	2.441	-	10	25		kHz
	2.480	-	9	25		kHz
-20dB bandwidth for modulated carrier	2.402	-	890	1000	≤ 1000	kHz
	2.441	-	870	1000		kHz
	2.480	-	820	1000		kHz
Carrier Frequency Drift (single slot packet DH1)	2.402	-	±10	±20	≤25	kHz
	2.441	-	±10	±20		kHz
	2.480	-	±10	±20		kHz
Carrier Frequency Drift (five slot packet DH5)	2.402	-	±10	±20	≤40	kHz
	2.441	-	±10	±20		kHz
	2.480	-	±10	±20		kHz
Drift Rate	2.402	-	±7	±14	≤20	kHz/50 μs
	2.441	-	±7	±14		kHz/50 μs
	2.480	-	±7	±14		kHz/50 μs
RF power control range		16	25	-	≥16	dB
Δf1** "Maximum Modulation"	2.402	145	165	170	140<Δf1**<175	kHz
	2.441	145	165	170		kHz
	2.480	145	165	170		kHz
Δf2*** "Minimum Modulation"	2.402	115	150	-	>115	kHz
	2.441	115	150	-		kHz
	2.480	115	150	-		kHz
Adjacent channel transmit power F=F ₀ ±2MHz		-	-35	-20	≤ - 20	dBm
Adjacent channel transmit power F=F ₀ ±3MHz		-	-45	-40	≤ - 40	dBm
Adjacent channel transmit power F>F ₀ +3MHz		-	-50	-40	≤ - 40	dBm
Adjacent channel transmit power F<F ₀ -3MHz		-	-50	-40	≤ - 40	dBm
Receiver , VDD = 3.3V Temperature =+20°C						
	Frequency (GHz)	Min.	Typ.	Max.	Bluetooth Specification	Unit
Sensitivity at 0.1% BER (Single slot packets)	2.402	-	-88	-86	≤ - 70	dBm
	2.441	-	-88	-86		dBm
	2.480	-	-88	-86		dBm
Sensitivity at 0.1% BER (Multi slot packets)	2.402	-	-88	-86	≤ - 70	dBm
	2.441	-	-88	-86		dBm
	2.480	-	-88	-86		dBm

Maximum received signal level at 0.1% BER	2.402	-20	-10	-	≥ -20	dBm
	2.441	-20	-10	-		dBm
	2.480	-20	-10	-		dBm
C/I co-channel	-	6	11		≤ 11	dB
Adjacent channel selectivity C/I F=F ₀ +1 MHz	-	-4	-		≤ 0	dB
Adjacent channel selectivity C/I F=F ₀ -1 MHz	-	-4	-		≤ 0	dB
Adjacent channel selectivity C/I F=F ₀ +2 MHz	-	-38	-		≤ -30	dB
Adjacent channel selectivity C/I F=F ₀ -2 MHz	-	-23	-		≤ -20	dB
Adjacent channel selectivity C/I F>F ₀ +3 MHz	-	-45	-		≤ -40	dB
Adjacent channel selectivity C/I F<F ₀ -5 MHz	-	-44	-		≤ -40	dB
Adjacent channel selectivity C/I F=F _{image}	-	-22	-		≤ -9	dB
F ₀ = 2441 MHz						
Maximum level of intermodulation interference (n=5)			-30		≥ -39	dBm

Radio Characteristics – Enhanced Data Rate

Transmitter, VDD = 3.3V Temperature = ±20°C						
	Frequency (GHz)	Min.	Typ.	Max.	Bluetooth Specification	Unit
Maximum RF transmit power ^(note)	2.402	-	16	-	-6 to +20	dBm
	2.441	-	16	-		dBm
	2.480	-	17	-		dBm
Relative transmit power		-	-1.6	-	-4 to +1	dB
π/4 DQPSK Maximum carrier frequency stability w ₀		-	2	-	≤ ±10 for all blocks	kHz
π/4 DQPSK Maximum carrier frequency stability w ₁		-	6	-	≤ ±75 for all packets	kHz
π/4 DQPSK Maximum carrier frequency stability w ₀ + w ₁		-	8	-	≤ ±75 for all blocks	kHz
8 DPSK Maximum carrier frequency stability w ₀		-	2	-	≤ ±10 for all blocks	kHz
8 DPSK Maximum carrier frequency stability w ₁		-	6	-	≤ ±75 for all packets	kHz
8 DPSK Maximum carrier frequency stability w ₀ + w ₁		-	8	-	≤ ±75 for all blocks	kHz
π/4 DQPSK Modulation Accuracy	RMS DVEM	-	7	-	≤ 20	%
	99% DEVM	-	13	-	≤ 30	%
	Peak DEVM	-	19	-	≤ 35	%
8 DPSK Modulation Accuracy	RMS DVEM	-	7	-	≤ 13	%
	99% DEVM	-	13	-	≤ 20	%
	Peak DEVM	-	17	-	≤ 25	%
In-band spurious emissions	F>F ₀ +3 MHz	-	<-50	-	≤ -40	dBm
	F<F ₀ -3 MHz	-	<-50	-	≤ -40	dBm
	F=F ₀ -3 MHz	-	-46	-	≤ -40	dBm
	F=F ₀ -2 MHz	-	-34	-	≤ -20	dBm
	F=F ₀ -1 MHz	-	-35	-	≤ -26	dBm
	F=F ₀ +1 MHz	-	-35	-	≤ -26	dBm
	F=F ₀ +2 MHz	-	-31	-	≤ -20	dBm

	F=F ₀ +3 MHz	-	-33	-	≤ -40	dBm
EDR Differential Phase Encoding			No Errors		≥ 99	%
Receiver , VDD = 3.3V Temperature =+20°C						
	Modulation	Min.	Typ.	Max.	Bluetooth Specification	Unit
Sensitivity at 0.1% BER	π/4 DQPSK	-	-87	-	≤ -70	dBm
	8 DPSK	-	-78	-	≤ -70	dBm
Maximum received signal level at 0.1% BER	π/4 DQPSK	-	-8	-	≥ -20	dBm
	8 DPSK	-	-10	-	≥ -20	dBm
C/I co-channel at 0.1% BER	π/4 DQPSK	-	10	-	≤ +13	dB
	8 DPSK	-	19	-	≤ +21	dB
Adjacent channel selectivity C/I F=F ₀ +1 MHz	π/4 DQPSK	-	-10	-	≤ 0	dB
	8 DPSK	-	-5	-	≤ +5	dB
Adjacent channel selectivity C/I F=F ₀ -1 MHz	π/4 DQPSK	-	-11	-	≤ 0	dB
	8 DPSK	-	-5	-	≤ +5	dB
Adjacent channel selectivity C/I F=F ₀ +2 MHz	π/4 DQPSK	-	-40	-	≤ -30	dB
	8 DPSK	-	-40	-	≤ -25	dB
Adjacent channel selectivity C/I F=F ₀ -2 MHz	π/4 DQPSK	-	-23	-	≤ -20	dB
	8 DPSK	-	-20	-	≤ -13	dB
Adjacent channel selectivity C/I F=F ₀ +3 MHz	π/4 DQPSK	-	-45	-	≤ -40	dB
	8 DPSK	-	-45	-	≤ -33	dB
Adjacent channel selectivity C/I F=F ₀ -5 MHz	π/4 DQPSK	-	-45	-	≤ -40	dB
	8 DPSK	-	-45	-	≤ -33	dB
F ₀ = 2405, 2441, 2477 MHz						
Adjacent channel selectivity C/I F=F _{image}	π/4 DQPSK		-20		≤ -7	dB
	8 DPSK		-15		≤ 0	dB

Note :

Measurement made using a POWER_TABLE entry of TX_PRE 80, INT PA63, EXT PA255. This ensures that the Bluetooth requirements for ACP and those defined by the FCC and ETSI are satisfied over the operating temperature range of -5°C to +45°C. Although the design is capable of generating in excess of +18dBm, regulatory compliance over the full temperature range of -5°C to +45°C will not be satisfied if the transmit power approaches this value.

Pin No.	Pin Name	Pin Type	Description
1	GND	GND	Common ground
2	PVCC	Power	Power Amp. Power Supply(3.3V)
3	AIO(0)	Bi-directional	Programmable I/O terminal , 32KHz sleep clock input
4	AIO(1)	Bi-directional	Programmable I/O terminal
5	PIO(0)	Bi-directional	Programmable I/O terminal, RX Enable
6	PIO(1)	Bi-directional	Programmable I/O terminal, TX Enable
7	PIO(2)	Bi-directional	Programmable I/O terminal, USB_PULL_UP, CLK_REQ_OUT
8	PIO(3)	Bi-directional	Programmable I/O terminal, USB_WAKE_UP, CLK_REQ_IN
9	PIO(4)	Bi-directional	Programmable I/O terminal, USB_ON, BT_Priority/Ch_Clk output for co-existence signalling

10	PIO(5)	Bi-directional	Programmable I/O terminal, USB_DETACH, BT_Active output for co-existence signalling
11	PIO(6)	Bi-directional	Programmable I/O terminal, CLK_REQ, WLAN_Active/Ch_Data input for co-existence signalling
12	PIO(7)	Bi-directional	Programmable I/O terminal
13	PIO(8)	Bi-directional	Programmable I/O terminal
14	PIO(9)	Bi-directional	Programmable I/O terminal
15	RESETB	CMOS input	Reset input of module, it must low for > 5ms to cause a valid reset
16	VCC	Power	Module power supply input
17	USB_DP	Bi-directional	USB data plus
18	USB_DN	Bi-directional	USB data minus
19	PCM_SYNC	Bi-directional	Synchronous data sync
20	PCM_IN	CMOS input	Synchronous data input
21	PCM_OUT	CMOS output	Synchronous data output
22	PCM_CLK	Bi-directional	Synchronous data clock
23	UART_RX	CMOS input	UART data input
24	UART_TX	CMOS output	UART data output
25	UART_RTS	CMOS output	UART request to send(active low)
26	UART_CTS	CMOS input	UART clear to send(active low)
27	SPI_MOSI	CMOS input	Serial Peripheral Interface data input
28	SPI_CSB	CMOS input	Chip select for Synchronous Serial Interface(active low)
29	SPI_CLK	CMOS input	Serial Peripheral Interface clock
30	SPI_MISO	CMOS output	Serial Peripheral Interface data output
31	PIO(11)	Bi-directional	Programmable I/O terminal
32	PIO(10)	Bi-directional	Programmable I/O terminal

Dimensions

Unit in mm

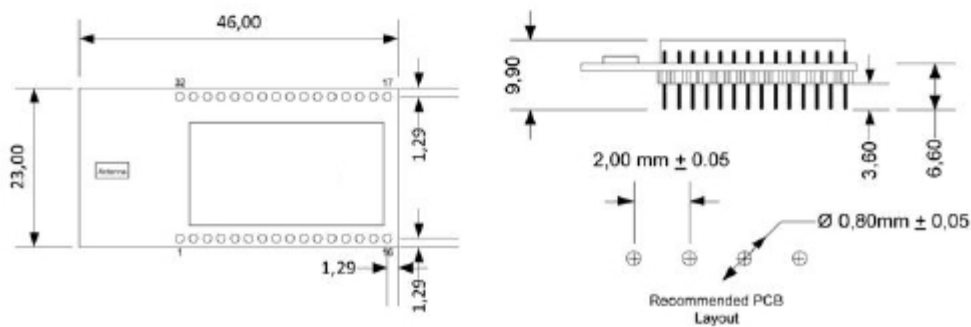

Appendix A

SPP Module User's Guide Revision 6.26

1. PIOs (programmable IOs) definition

- PIO4, For connection/re-pair/restore button, high active. To press the button caused disconnection or reconnection. To double click the button caused clear all original link records then repairing. When user press the button more than 3 seconds, then it will restore the default RS232 setting. The device will enter DUT mode when the PIO4 hold high for 2 seconds during power up stage.
- PIO5, For data led indication, high active. When data stream are trafficking
- PIO6, For RFCOMM connection status, low active.
- PIO7, For link led indication, high active.

The following is the LED status information :

Status	Description
Link LED off	No pairing established
Link LED fast (0.1 sec.) blinking	Pairing (Slave or Master mode)
Link LED fast (0.3 sec.) blinking	Discoverable and waiting for a connection (slave mode)
Link LED slow (0.9 sec.) blinking	Inquiring (Master Mode)
Link LED very slow (1.2 sec.) blinking	Connecting (Master Mode)
Link LED steadily on	Connection established

- PIO8 - For power led indication, high active. When it's deep sleep the output is low.
- PIO9 - Output controlled by ATS command
- PIO3 - PIO2,PIO11,PIO10 are reserved for Programmable I/O

2. SPP AT Command Sets

+++ Escape Sequence with guard time

When the device is in Data Mode, it can be forced back into online command Mode while maintaining the connection to the remote device.

○ Online Data Mode or Auto connect setting in master role

The command directs the device to switch from Command Mode to Data Mode. By the way, it is used to enable/disable auto-connection feature in master role.

Modifiers and Description

- O Switch from Command Mode to Online Data Mode
- O0 (Default Setting) Automatically connecting to any available device or a device which is assigned in "ATD=xxxxxxxxxx". (The command will cause reboot)
- O1 Disable auto-connection feature, user should manually use "ATA"command to connect a remote device. (The command will cause reboot)
- O? Inquire the current setting

A Establish a connection

When it's in master mode. This command establish a connection. When it's in slave mode, the command will be rejected.

Modifiers and Description

- A Connect to a Bluetooth device (It's only available when "ATD= xxxxxxxxxxxx" assigned)
- A1~A8 Connect to a Bluetooth neighborhood device 1~8 (ATF? Result)

B Display local BD address

This command display the local device BD address

Modifiers and Description

- B? Inquire the Local BD address

C Flow Control

This command enable or disable flow control signals (CTS/RTS) of the COM port. Note, the setting is not affected by ATZ0 and **cause reboot**.

Modifiers and Description

- C0 Disable flow control.(This command is not valid when it's running DUN profile)
- C1 (Default Setting) Enable flow control.

C? Inquire the current setting

D Set Remote BD Address

We can specify the unique remote device can be connected. In master role, it automatically inquire and search the slave even the slave is undiscoverable. In slave role, the command should be as a filter condition to accept the master's inquiry.

Modifiers and Description

D=XX "XXXX-XX-XXXXXX" is a 12 digit hex symbol

D0 (Default Setting) Clear Remote BD address setting, inquire any slave in master mode or accept any master in slave mode.

D? Inquire the Remote BD address setting

E Local Echo

This command specifies whether the device should echo characters received from the UART back to the DTE/DCE.

Modifiers and Description

E0 Command characters received from the UART are not echoed back to the DTE/DCE.

E1 (Default Setting) Command characters received the UART are echoed back to the DTE/DCE.

E? Inquire the current setting

F Find Bluetooth Device

This command is used to find any bluetooth device in neighborhood within 60 seconds timeout. If any device is found, its name and address will be listed. The search ends with a message "Inquiry ends, xx device(s) found."

This command is valid only when the device is in the master role and manual operation mode(AT01). **Note : One AT can cancel the searching at any time.**

Modifiers and Description

F? Inquire scan Bluetooth neighborhood devices.

F=nn Set the maximum devices number, default is 8, is limited.

G Power Management Control

This command control deep sleep timer. The device will enter deep sleep mode whenever there are no any event activity before connection and turn off all leds. The timer will restart once any event interrupt the timer. The device can wake up once UART or PIO4 receive a proper signal.

Modifiers and Description

- G=nnnnn Deep sleep timer, nnnnn is 60~65536 seconds, the accuracy is +/-2 seconds.
- G=0 (Default setting) Disable Deep sleep timer
- G? Inquire the current setting

H Drop a connection and Discoverable Control

This command can drop the connection either master or slave role. By the way, it specifies whether the device could be discovered by remote master device.

Modifiers and Description

- H Drop current connection
- H0 The device enters undiscoverable mode. If a pair have been made, the original connection could be connected again. Other remote master device can not discovery this device. (The command will cause reboot)
- H1 (Default Setting) The device enters discoverable mode. (The command will cause reboot)
- H? Inquire the current setting

I Information

This command is used to Inquiry information

Modifiers and Description

- I0 Inquire the FW version
- I1 Inquire the all settings list
- I2 Inquire the RSSI with value at Online Command mode.

K I? Inquire the FW version
Stop Bits Setting

This command is used to specify one or two stop bits of COM port

Modifiers and Description

- K0 (Default Setting) One Stop Bit
- K1 Two stop bits
- K? Inquire the current setting

L **Baud Rate Control**

This command is used to specify the baud rate of COM port

Modifiers and Description

- L* 1200bps
- L# 2400bps
- L0 4800bps
- L1 9600bps
- L2 (Default Setting) 19200bps
- L3 38400bps
- L4 57600bps
- L5 115200bps
- L6 230.4Kbps
- L7 460.8Kbps
- L8 921.6Kbps
- L? Inquire the current setting

M Parity Bits Setting

This command is used to specify the parity bit setting of COM port

Modifiers and Description

- M0 (Default Setting) None Parity Bit
- M1 Odd parity setting.
- M2 Even parity setting
- M? Inquire the current setting

N Set Device Name

We can specifies the device a friendly name using 0 to 9, A to Z, a to z, space and -, which are all valid characters. Note that "firs space or -, last space or - isn't permitted". The default name is "Serial Adaptor"

Modifiers and Description

- N=xxxxx "xxxxx" is a character string, maxima length is 31
- N? Inquire the device name

P Set Pin Code

This command specifies the PIN number. It control to off the PIN code authorization that allow to establish a connection without PIN code. **The default PIN number is "1234"**

Modifiers and Description

- P=xxxx (Default Setting)"xxxx" is 4~8 digit string
- P0 Turn off the PIN code authorization
- P? Inquire the current PIN number

Q Result Code Suppression

The command is used to determine if result Codes should be sent to the DTE/DCE. When result Codes are suppressed, the device does not generate any (Result Code Suppression) characters in response to the completion of a command or when an event occurs.
Four Result Codes : OK,CONNECT,DISCONNECT,ERROR

Modifiers and Description

- Q0 (Default Setting)The device will send out Result Codes.
- Q1 The device will not send out Result Codes.
- Q? Inquire the current setting

R Set Role

This command specifies whether the device could be master or slave device. If change the role, the device will reboot and clear all paired records.

Modifiers and Description

- R0 The device as SPP master role.
- R1 (Default Setting) The device as SPP slave role.
- R2 The device as DUN master role.
- R3 The device as DUN slave role.
- R? Inquire the current setting

S Program PIOs Settings

PIO9 signals setting

Modifiers and Description

- S0 Disable RS232 force on for auto power down.(PIO9 output low).
- S1 (Default Setting)Enable RS232 force on. (PIO9 output high)

S? Inquire the current setting

X Set Escape Sequence

Disable/Enable escape sequence "+++" with one second guard time. The sequence was a command used to enter On Line Command Mode from Data Mode.

Modifiers and Description

X0 Disable Escape Sequence feature. *If the baud rate is higher than 230.4k, please disable this feature.*

X1 Enable Escape Sequence feature

X? Inquire the current setting

U F/W Upgrade

This command will prompt "Enter DFU mode, Are you sure (y/n)?" message, then press Y to confirm the command. Then you should connect USB cable to PC and run DFU wizard.

Modifiers and Description

U=password Pass word = RaysonUpgrade ,Enter F/W Upgrade Mode

Z Application Setting

Restore different application setting and warm start.

Modifiers and Description

Z0 Restore default setting.

Z? Inquire the current setting

The pattern to use the Escape Mode
Time Elapse



Data Mode	Guard Time (1s)	“+++”	Guard Time (1s)	Command Mode
-----------	-----------------	-------	-----------------	--------------

Notes:

1. Guard Time: is a timer of 1 second, it means that there is nothing inputted, keeps silence on the UART.

2. Typical steps to enter command mode:
 - 2.1. Input a non '+' character to restart the guard timer, e.g. a CR character.
 - 2.2. Wait about 1s+X(ms), don't input anything during this period, just wait.
 - 2.3. Input “+++” string, or input three '+' one by one.
 - 2.4. Wait about 1s+X(ms), don't input anything during this period, just wait.
 - 2.5. The BT module will response an “OK” to enter command mode.

3. X: to tune X parameter, it may be 50ms~100ms.

Appendix B

Pairing Feature

It can store pairing information for up to eight different device. Devices are not stored in a “Paired Device List” in memory by chronological order. When an attempt to pair to more than eight devices is made, the oldest paired device is removed from the list. Any of the eight paired devices can make a connection to the BT device, but only automatically initiate a paired connection with the last device it was connected to. Whichever of the eight devices initiate a connection to the BT device afterwards, that device then becomes the “last connected” device.

 **Bluetooth® Qualified Product Notice****BQB: Juei-Hsin Chin**Hyper Taiwan Technology, Inc.
7F-1, No. 92, Sec.1 Nei-Hu Rd., Taipei Taiwan, R.O.C. 114

QPN Number	QPNHTTJ050	Assessment Date	11.10.2005
		Listing Date	11.10.2005

Applicant Information

Applicant	Rayson Technology Co., Ltd	Contact Person	Tim Lin
Address	1F, No. 9, R&D Rd. 2, Science-Based Industrial Park, Hsin-Chu, 300 Taiwan, R.O.C	Phone Number	+886.3.563.3666
		Fax Number	+886.3.563.3688
URL	http://www.rayson.com	Email Address	sales@mail.rayson.com

Manufacturer Information

Manufacturer	Same as above
Address	Same as above

Product Information

Product Name	Class 1 Module	Product Category	Components
Product ID	BTM-22x, BTM-23x	Product Type	Comp-HW-Integrated
Hardware Version	A1	Software Version	N/A
Firmware Version	cyt_8unified_fl_bt2.0_19p2		
Supported Protocol	RF, BB, LM, HCI, HCI-USB, HCI-RS232, HCI-UART, L2CAP, SDP, RFCOMM		
Supported Profile	GAP, SPP		

Reference Information

Product Reference Document	V1.0
Bluetooth Specification	V2.0 + EDR
Test Case Reference List	TCRL_EDR_2005-1-BQRB1, TCRL_P1_1_2005-1-BQRB1

I certify that the Class 1 Module has a *Bluetooth* Brand License based on the requirements as described in Section 6.2.1, Pre-Tested *Bluetooth* Components, of the *Bluetooth* Program Reference Document 1.0