



BTM8630

Bluetooth Module Data Sheet

Document Type: Bluetooth Module Datasheet
Document Version: V1.01
Release Date: Sep 13, 2013

Copyright 2012 by Buddies Technology Limited. All Rights Reserved.

Reproduction of this document, in part or in whole, by any means is prohibited without written permission from Buddies Technology Limited. The information contained herein is believed to be accurate as of the date of publication. However, Buddies is not liable for any damages, including indirect or consequential from the use of software this document represents, or any reliance of the accuracy of this document. Buddies reserves the right to change the contents of this document at any time without notice.

This document contains proprietary confidential trade secrets and may be subject to additional restrictions contained in the licensing agreement under which this document was obtained.



Revision History

Date	Version	Description	Author
2013-08-29	V1.0	■ First Release	
2013-09-13	V1.01	■ Update PIOx operation condition	



CONTENT

- 1. INTRODUCTION.....4**
- 1.1 BLOCK DIAGRAM.....4
- 1.2 FEATURES5
- 1.3 APPLICATIONS5
- 2. GENERAL SPECIFICATION6**
- 3. PHYSICAL CHARACTERISTIC.....8**
- 3.1 Pin Description..... 8
- 4. REFERENCE SCHEMATIC 10**
- 5. PHYSICAL INTERFACE.....11**
- 5.1 Programmable I/O ports.....11
- 5.2 Analogue I/O ports.....11
- 5.3 LED driver11
- 5.4 Audio interfaces 11
- 5.5 Reset..... 11
- 5.6 RF interface..... 11
- 5.7 Batter charger e.....12
 - 5.7.1 Battery charger hardware operating modes 12
 - 5.7.2 External charge mode 12
- 5.8 Serial interfaces..... 12
 - 5.8.1 UART..... 12
 - 5.8.2 SPI..... 13
- 6. ELECTRICAL CHARACTERISTIC14**
- 6.1 Absolute maximum ratings 14
- 6.2 Recommended operating conditions14
- 6.3 PIO recommended operating conditions14
- 6.4 Battery chargers.....15
- 6.5 External charge mode.....15
- 6.6 RF characteristics..... 16
- 6.7 Power consumptions.....16
- 7. PACKAGING INFORMATION17**



1. INTRODUCTION

The BTM8630 Bluetooth® module is a perfect solution for enhanced audio applications, such as stereo speakers. It can be connected with any Bluetooth® devices in an operating range. It is slim and light so the designers can have better flexibilities for the product shapes.

The BTM8630 Bluetooth® module complies with Bluetooth® specification version 4.0. It supports A2DP, AVRCP profiles. It integrates RF Baseband controller, antenna,... etc. and provide UART interface, programmable I/O, stereo speaker output... etc.

The detail information of BTM8630 Bluetooth® module is presented in this document below.

1.1 Block Diagram

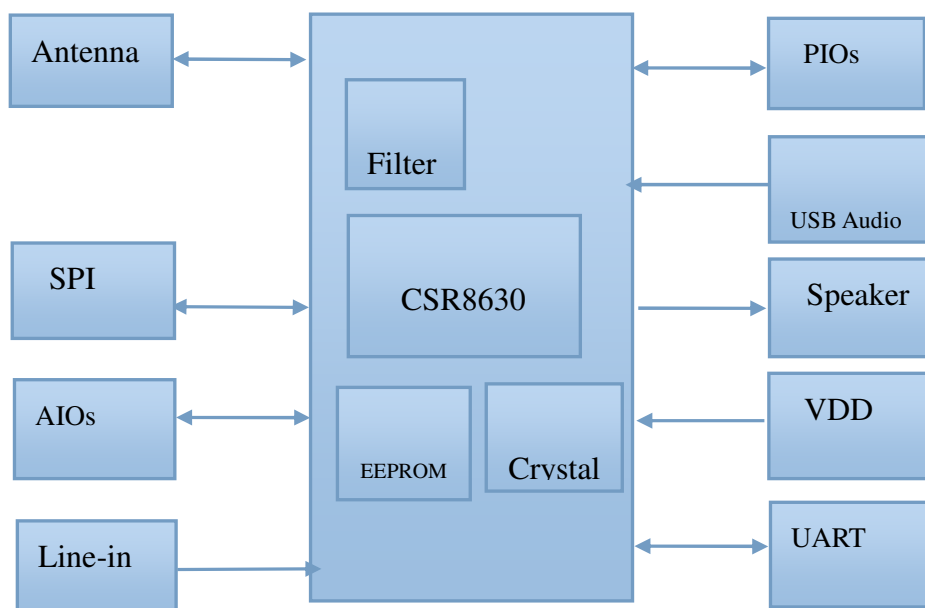



1.2 Features

- ✓ Small overall dimension
- ✓ Bluetooth® V4.0
- ✓ Class 2 support
- ✓ Physical connection as SMD type
- ✓ High quality stereo audio
- ✓ Music Enhancements: SBC,MP3,AAC and Faststream decoder, Configurable EQ, Stereo Widening(S3D)
- ✓ Support SMSC-T
- ✓ Support A2DP, AVRCP profile
- ✓ Based on CSR chip set CSR8630
- ✓ RoHS Compliant
- ✓ No radio signal interference, support for 802.11 co-existence
- ※ *Some features are optional for customization on demand.*

1.3 Application

- ✓ High Quality Stereo Bluetooth Headsets
- ✓ High Quality Wired Stereo Headsets
- ✓ Bluetooth Speakers



2. GENERAL SPECIFICATION

Bluetooth Specification	
Chip Set	CSR 8630 (ROM)
Module ID	BTM8630
BT Standard	Bluetooth® V4.0
RF TX Output Power	4dBm (Class II)
Sensitivity	-86dBm@0.1%BER
Frequency Band	2.402GHz~2.480GHz ISM Band
Baseband Crystal OSC	26MHz
Hopping	1600hops/sec, 1MHz channel space
RF Input Impedance	50 ohms
Environmental	RoHS Compliant

3. PHYSICAL CHARACTERISTIC

3.1 Pin Description

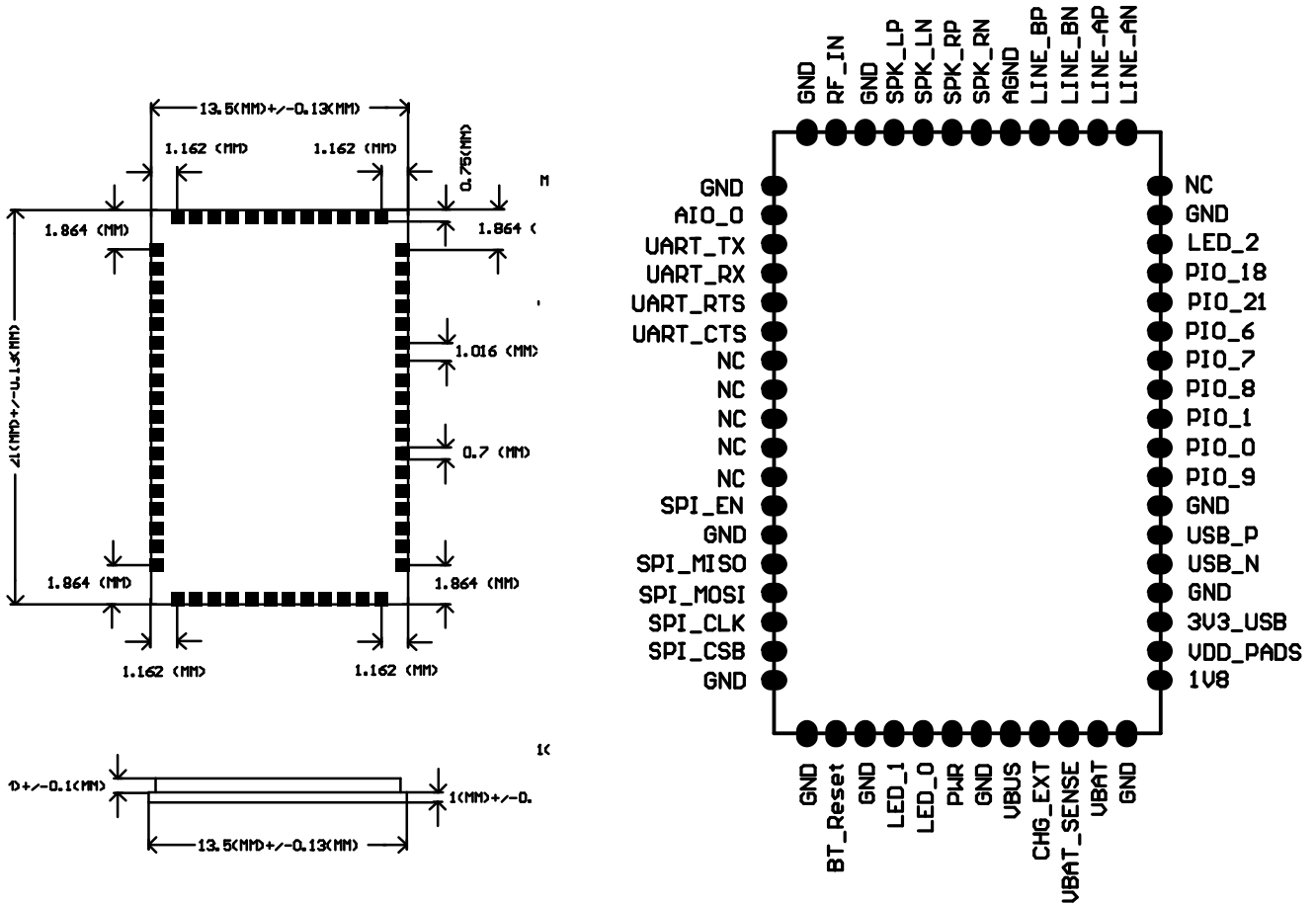



Pin#	Pin Name	Pad Type	Description
1	GND	Ground	Ground
2	AIO_0	Bi-directional VDD/Low-voltage regulator output	Analogue programmable input/ output line circuitry and 1.5V regulated output (from internal low-voltage regulator)
3	UART_TX	Bi-directional CMOS output, tri-state, with weak internal pull-up	UART data output
4	UART_RX	CMOS input with weak internal pull-down	UART data input
5	UART_RTS	Bi-directional CMOS output, tri-state, with weak internal pull-up	UART request to send active low
6	UART_CTS	CMOS input with weak internal pull-down	UART clear to send active low
7	NC	NC	NC
8	NC	NC	NC
9	NC	NC	NC
10	NC	NC	NC
11	NC	NC	NC
12	SPI_EN	Bi-directional with programmable strength internal pull-up/down	SPI select input: 1: SPI
13	GND	Ground	Ground
14	SPI_MISO	CMOS output, tri-state, with weak internal pull-down	SPI data output
15	SPI_MOSI	CMOS input, with weak internal pull-down	SPI data input
16	SPI_CLK	Input with weak internal pull-down	SPI clock
17	SPI_CSB	Input with weak internal pull-up	Chip select for Serial Peripheral Interface (SPI),active low
18	GND	Ground	Ground



19	GND	Ground	Ground
20	BT_Reset	CMOS input with weak internal pull-up	Active LOW reset
21	GND	Ground	Ground
22	LED_1	Open drain output	LED driver
23	LED_0	Open drain output	LED driver
24	PWR	Analogue	Take high to enable high-voltage linear regulator and switch-mode regulator
25	GND	Ground	Ground
26	VBUS	Power input	Charger input
27	CHG_EXT	Analogue out	External battery charger control
28	VBAT_SENSE	Analogue out	Battery charger sense input
29	BVAT	Powr in	Battery positive terminal
30	GND	Ground	Ground
31	1V8_OUT	Power	High-voltage linear regulator output (1.8V out)
32	VDD_PADS	Powr in	Positive supply input for input/output ports
33	3V3_OUT	Power out	3.3V bypass linear regulator output
34	GND	Ground	Ground
35	USB_N	Bi-directional	USB data minus
36	USB_P	Bi-directional	USB data plus with selectable internal 1.5k Ω pull-up resistor
37	GND	Ground	Ground
38	PIO_9	Bi-directional with programmable strength internal pull-up/down	Programmable input/output line



39	PIO_0	Bi-directional with programmable strength internal pull-up/down	Programmable input/output line
40	PIO_1	Bi-directional with programmable strength internal pull-up/down	Programmable input/output line
41	PIO_8	Bi-directional with programmable strength internal pull-up/down	Programmable input/output line
42	PIO_7	Bi-directional with programmable strength internal pull-up/down	Programmable input/output line
43	PIO_6	Bi-directional with programmable strength internal pull-up/down	Programmable input/output line
44	PIO_21	Bi-directional with programmable strength internal pull-up/down	Programmable input/output line
45	PIO_18	Bi-directional with programmable strength internal pull-up/down	Programmable input/output line
46	LED_2	Open drain output	LED driver
47	GND	Ground	Digital Ground
48	MIC_BIAS	Analogue	Microphone bias
49	LINE_AN	Analogue	Line-in negative, right
50	LINE_AP	Analogue	Line-in positive, right
51	LINE_BN	Analogue	Line-in negative, left
52	LINE_BP	Analogue	Line-in positive, left
53	AGND	Ground	Analog Ground
54	SPK_RN	Analogue	Speaker output negative, right
55	SPK_RP	Analogue	Speaker output positive, right
56	SPK_LN	Analogue	Speaker output negative, left
57	SPK_LP	Analogue	Speaker output positive, left
58	GND	Ground	Digital Ground
59	RF	RF	RF out
60	GND	Ground	Digital Ground

4. REFERENCE SCHEMATIC

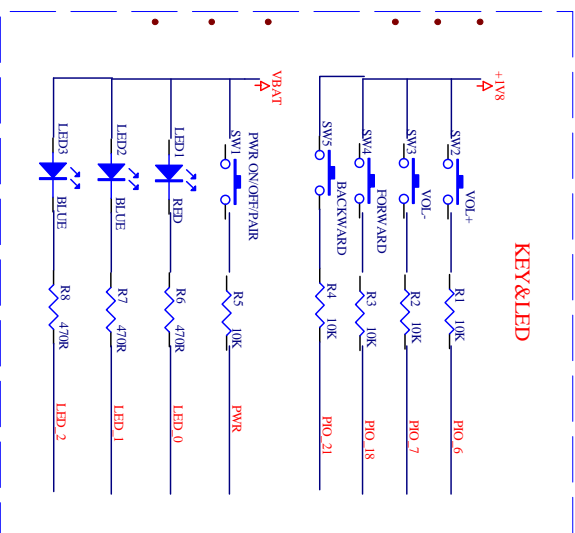
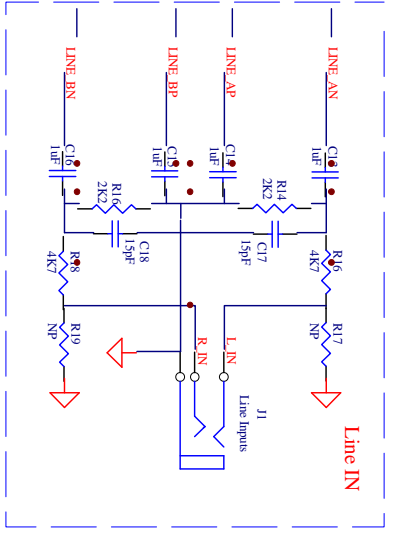
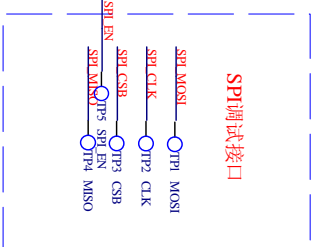
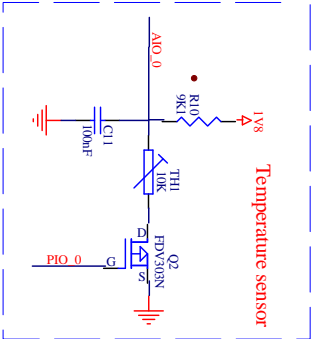
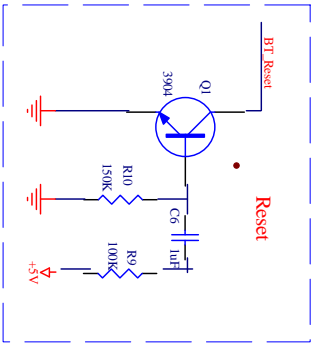
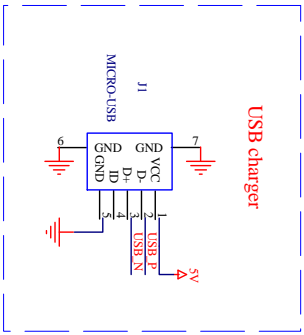
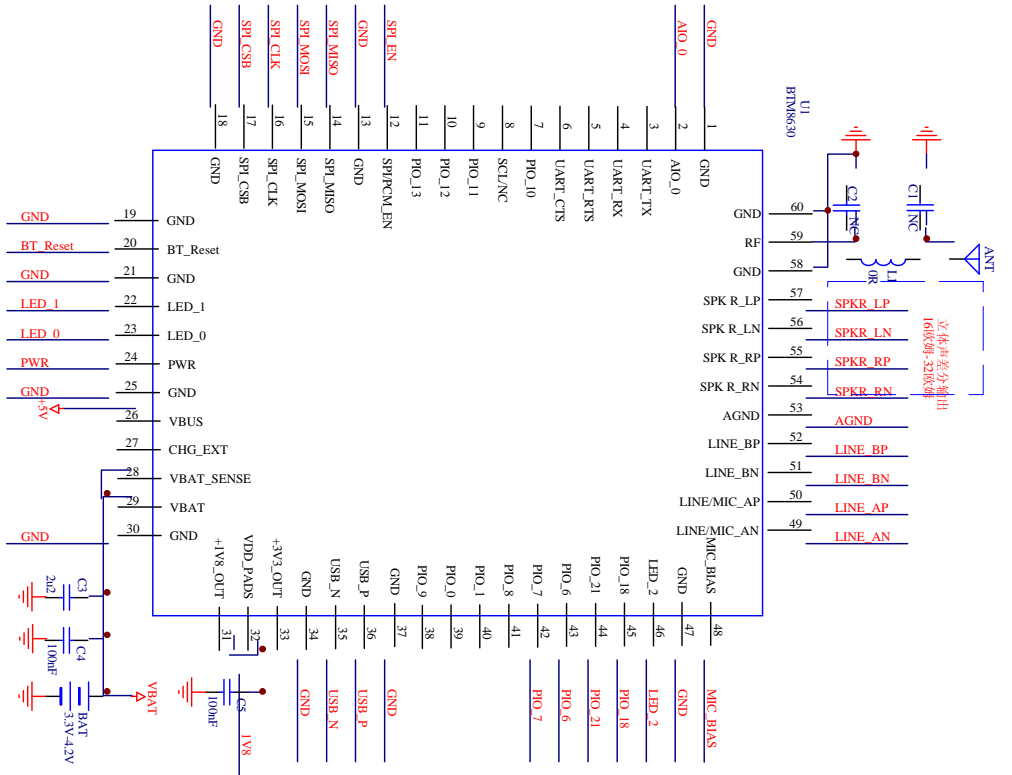



5. PHYSICAL INTERFACE

5.1 Programmable I/O ports

- The module provide 11 lines of programmable bidirectional I/O, Can configured to different function by firmware.

5.2 Analogue I/O ports

- The module has a analogue port AIO_0, typically connections to thermistor for battery pack temperature measurements during charger control.

5.3 LED Driver

- The module provide 3 synchronized PWM LED driver for RGB leds. Can controlled by firmware. The driver are open-drain outputs, and the LEDs must pull up to positive supply. Refer to the section 4.1

5.4 Audio Interfaces

Audio interface as following features:

Stereo or dual mono analogue audio output through SPK_LP, SPK_LN, SPK_RP, SPK_RN.

- Stereo and mono analogue input through LINE_AN, LINE_AP, LINE_BN, LINE_BP.

The module is designed for different output, if a single-ended audio output is required, use an external differential to single-ended converter.

5.5 Reset

- The module is reset from several sources:
 - Reset# pin
 - Power on reset
 - Software configured watch-dog

The Reset pin is an active low reset and is internally filtered using the internal low frequency clock oscillator. Recommended the low period >10ms.

RAM data not available after cold reset.



shows pin states of module on reset

Pin name	I/O type	Reset			
PIO_0	Digital Bidirectional	Strong pull up	PIO_18	Digital Bidirectional	Strong pull down
PIO_1	Digital Bidirectional	Strong pull up	PIO_21	Digital Bidirectional	Weak pull down
PIO_6	Digital Bidirectional	Strong pull down			
PIO_7	Digital Bidirectional	Strong pull down			
PIO_8	Digital Bidirectional	Strong pull up			
PIO_9	Digital Bidirectional	Strong pull down			

5.6 RF Interface

The module integrates a balun filter. A 50ohms load is needed.

5.7 Batter charger

5.7.1 battery charger hardware operating modes

The battery charger hardware is controlled by VM ,it has 5 modes:

Disabled

Trickle charger

Fast charger

Standby: fully charged or float charge

Error: charging input voltage, VCHG is too low.

5.7.2 External charge mode

The external mode is for charging higher capacity batteries using an external bass device. The current is controlled by sinking a varying current into the CHG_EXT pin, and the current is determined by measuring the voltage drop across a resistor. The max current up to 700mA.

5.8 Serial Interfaces

5.8.1 UART

This is a standard UART interface for communicating with other serial devices. The UART interface provides a simple mechanism for communicating with other serial devices using the RS232 protocol.



When the module is connected to another digital device, UART_RX and UART_TX transfer data between the two devices. The remaining two signals, UART_CTS and UART_RTS, can be used to implement RS232 hardware flow control where both are active low indicators.

Note: The serial port interface(UART)can be used for system debugging. Don't support to use command set for profile function application by UART, such as HFP/A2DP/AVRCP and so on. These profiles function application can be controlled only by PIO, such as pairing/connect/answer/play/pause/next/previous function application and so on.

5.8.2 SPI

The synchronous serial port interface (SPI) can be used for system debugging. It can also be used for in-system programming for the flash memory within the module. SPI interface uses the SPI_MOSI, SPI_MISO, SPI_CSB and SPI_CLK pins. Testing points for the SPI interface are reserved on board in case that the firmware shall be updated during manufacture.

The module operates as a slave and thus SPI_MISO is an output of the module. SPI_MISO is not in high-impedance state when SPI_CSB is pulled high. Instead, the module outputs 0 if the processor is running and 1 if it is stopped. Thus the module should NOT be connected in a multi-slave arrangement by simple parallel connection of slave SPI_MISO lines.

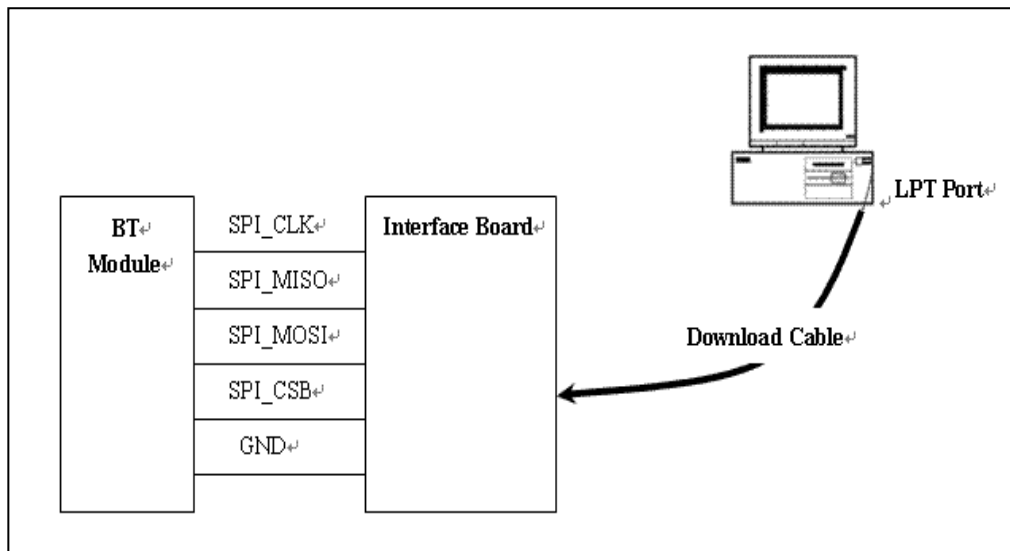



6.ELECTRICAL CHARACTERISTIC

6.1 Absolute Maximum Ratings

6.2 Recommended Operating Conditions

6.3 PIO recommended operating conditions

Rating	Min	Max	Unit
Storage temperature	-40	105	°C
Supply Voltage			
VBUS	-0.4	5.75	V
VBAT_SENSE	-0.4	4.20	V
PWR	-0.4	4.40	V

Rating	Min	Typ	Max	Unit
Operating temperature range	-40		85	°C
Supply Voltage				
VBAT	2.8	3.30	4.25	V
VBUS	4.75	5.00	5.75	V
VBAT_SENSE	0	3.70	4.30	V
PWR	0	3.30	4.25	V

Input Voltage	Min	Typ	Max	Unit
PIOx	1.70	1.80	3.6	V
AIOx	1.30	1.35	1.40	V
LED[0:2]	1.10	3.30	4.25	V

Output	Min	Typ	Max	Unit
PIOx	1.70	1.80		V
LED[0:2]	0	0		V



Output current with 3.3v supply	Min	Typ	Max	Unit
PIOx(Total output)			5.0	mA

Current with 3.3V Input and Tristate	Min	Typ	Max	Unit
Strong pull up	-150	-40	-10	uA
Strong pull down	10	40	150	uA
Weak pull up	-5	-1.0	-0.33	uA
Weak pull down	0.33	1.0	5.0	uA

6.4 Battery charger

Fast Charge mode	Min	Typ	Max	Unit
Charge current during constant charge mode	194	200	206	mA
Standby mode	100	-	150	mA

6.5 External charge mode

	Min	Typ	Max	Unit
Fast Charge current during constant charge mode	200	-	500	mA
Control current into CHG_EXT	0	-	20	mA



6.6 RF characteristics

Receiver		Average	Bluetooth Spec	Transmitter		Average	Bluetooth Spec	Unit
Sensitivity at 0.1 Ber	2402MHz	-85	<=-70	Output Power	2402MHz	3.6	-6~+4	dBm
	2441MHz	-86			2441MHz	3.4		dBm
	2480MHz	-86			2480MHz	3.5		dBm

6.7 Power consumption

Operating Condition		Average Current	Unit
Slave	SCO connection with pocket type HV3	12.1	mA
	eSCO connection with pocket type EV3	12.4	mA
	eSCO connection with pocket type 2EV3	10.1	mA
	Stereo with high quality SBC decode	15.2	mA
Master	SCO connection with pocket type HV3	11.2	mA
	eSCO connection with pocket type EV3	12.3	mA
	eSCO connection with pocket type 2EV3	9.2	mA
	Stereo with high quality SBC decode	15.0	mA



7. PACKAGING INFORMATION

1. BLUETOOTH® Module: BTM8630

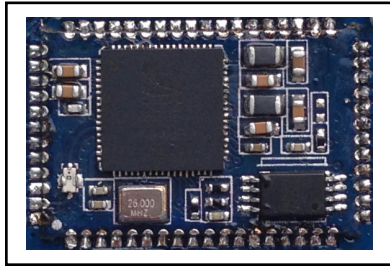

2. Assembly

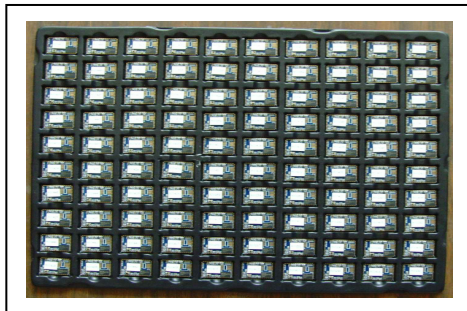

3. Dimension

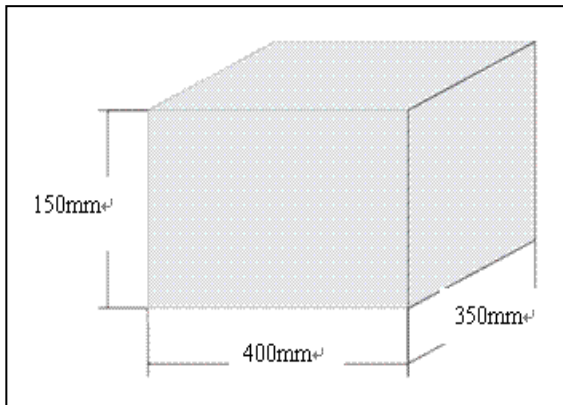

All rights are strictly reserved. Any portion of this paper shall not be reproduced, copied, or translated to any other forms without permission from Buddies Technology Limited.