



BTMC6R28

Bluetooth Module Data Sheet

Document Type: Bluetooth Module Datasheet
Document Version: V1.04
Release Date: February 16,2016

Copyright 2016 by Buddies Technology Co., Ltd. All Rights Reserved.

Reproduction of this document, in part or in whole, by any means is prohibited without written permission from Buddies Technology Co., Ltd. The information contained herein is believed to be accurate as of the date of publication. However, Buddies is not liable for any damages, including indirect or consequential from the use of software this document represents, or any reliance of the accuracy of this document. Buddies reserves the right to change the contents of this document at any time without notice. *This document contains proprietary confidential trade secrets and may be subject to additional restrictions contained in the licensing agreement under which this document was obtained.*



Revision History

Date	Version	Description	Author
2015-08-10	V1.0	n First Release	
2015-09-04	V1.01	n Add reflow profile	
2015-09-25	V1.02	n Add reference schematic	
2015-11-12	V1.03	n Update: Bluetooth V4.2, Class 1	
2016-02-16	V1.04	n Update module dimension	



CONTENT

1. INTRODUCTION.....	4
1.1 BLOCK DIAGRAM.....	4
1.2 FEATURES	5
1.3 APPLICATIONS	6
2. GENERAL SPECIFICATION	7
3. PHYSICAL CHARACTERISTIC.....	8
3.1 Pin Description.....	10
4. REFERENCE SCHEMATIC.....	14
5. PHYSICAL INTERFACE.....	15
5.1 Programmable I/O ports.....	15
5.2 Analogue I/O ports.....	15
5.3 LED driver	15
5.4 Audio interfaces	15
5.5 Microphone input.....	15
5.6 Reset.....	15
5.7 RF interface.....	16
5.8 Batter charger e.....	16
5.8.1 Battery charger hardware operating modes.....	16
5.8.2 External charge mode.....	16
5.9 Serial interfaces.....	16
5.9.1 UART.....	16
5.9.2 SPI.....	17
6. ELECTRICAL CHARACTERISTIC.....	18
6.1 Absolute maximum ratings	18
6.2 Recommended Operating Conditions	18
6.3 PIO recommended operating conditions	18
6.4 Battery chargers.....	19
6.5 External charge mode.....	19
6.6 RF characteristics.....	20
6.7 Power consumptions.....	20
7. REFLOW PROFILE.....	21
8. PACKAGING INFORMATION	22



1. INTRODUCTION

The BTMC6R28 Bluetooth® module is a perfect solution for enhanced audio applications, such as mono speaker. It can be connected with any Bluetooth® devices in an operating range. It is slim and light so the designers can have better flexibilities for the product shapes.

The BTMC6R28 Bluetooth® module complies with Bluetooth® specification version 4.2. It supports HSP, HFP, A2DP, AVRCP profiles, and TrueWireless Stereo (TWS) application. It integrates RF Baseband controller, antenna, ... etc. and provides UART interface, programmable I/O, mono speaker output, microphone input, ... etc.

The detail information of BTMC6R28 Bluetooth® module is presented in this document below.

1.1 Block Diagram

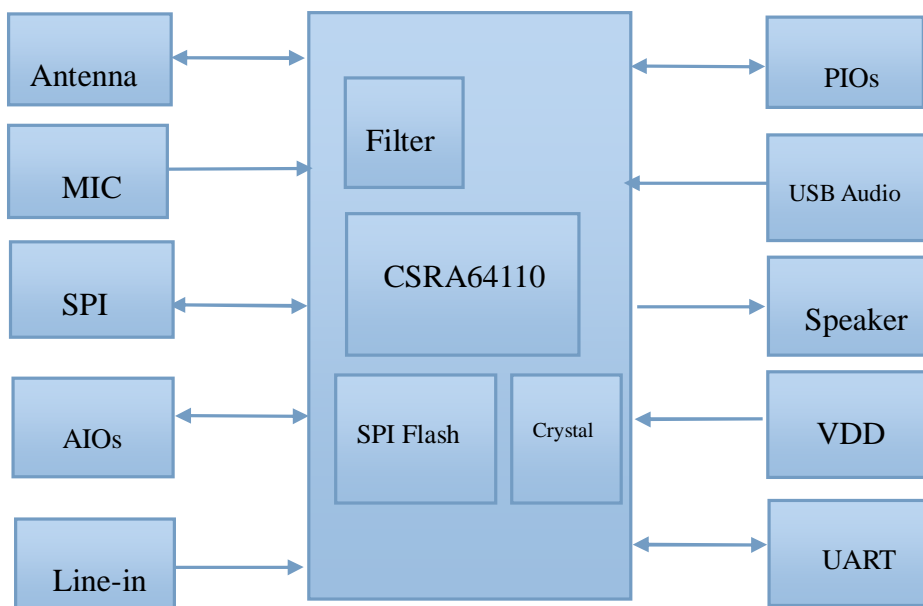

Note: SPI & UART only for production test



1.2 Features

- ü Small overall dimension (8M/16M: 21 * 13.5 * 2.85mm; 4M:21 * 13.5 * 2.5mm)
- ü Bluetooth® V4.2
- ü Class 1, Class 2, Class 3 support
- ü Physical connection as SMD type
- ü High quality mono audio
- ü Music Enhancements: SBC, AAC decoder, Configurable EQ
- ü TrueWireless Stereo (TWS)
- ü Support audio analog(line-out) and digital(I2S) output
- ü Support SCMS-T
- ü Support HSP(v1.2), HFP(v1.6), A2DP(v1.3), AVRCP(v1.5) profiles
- ü CSR's latest cVc technology for narrowband and wideband voice connections including wind noise reduction
- ü Multipoint support for A2DP connection to 2 A2DP sources for music playback
- ü Based on CSR chip set CSRA64110
- ü RoHS Compliant
- ü No radio signal interference, support for 802.11 co-existence
- ※ *Some features are optional for customization on demand.*



1.3 Application

- ü High Quality Mono Bluetooth Headphone
- ü Bluetooth Speaker



2. GENERAL SPECIFICATION

Bluetooth Specification	
Chip Set	CSRA64110 (ROM)
Module ID	BTMC6R28
BT Standard	Bluetooth® V4.2
RF TX Output Power	4dBm(typ),8dBm(max)
Sensitivity	-86dBm@0.1%BER
Frequency Band	2.402GHz~2.480GHz ISM Band
Modulation Type	GFSK, $\pi/4$ DQPSK,8DPSK
Channel No.	79(for Classic),40(for BLE)
Baseband Crystal OSC	26MHz
Hopping	1600hops/sec, 1MHz channel space
RF Input Impedance	50 ohms
Environmental	RoHS Compliant



3. PHYSICAL CHARACTERISTIC

BTMC6R24/28/29-4M

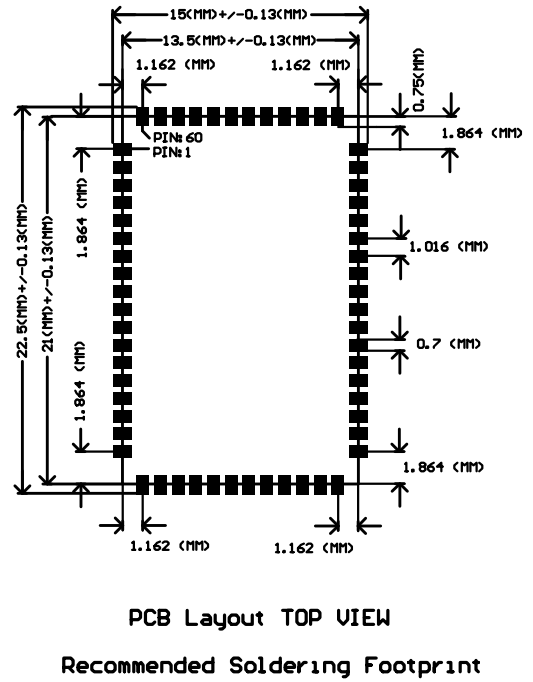
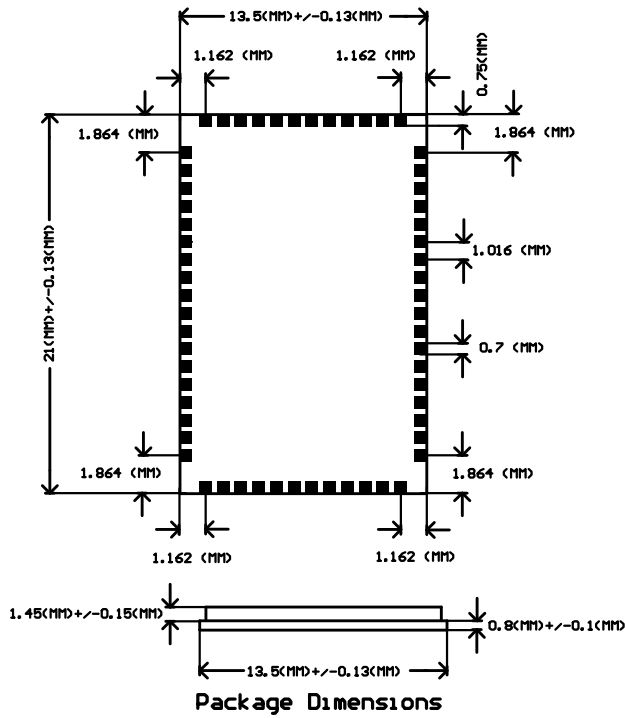

BTMC6R24/28/29-8/16M

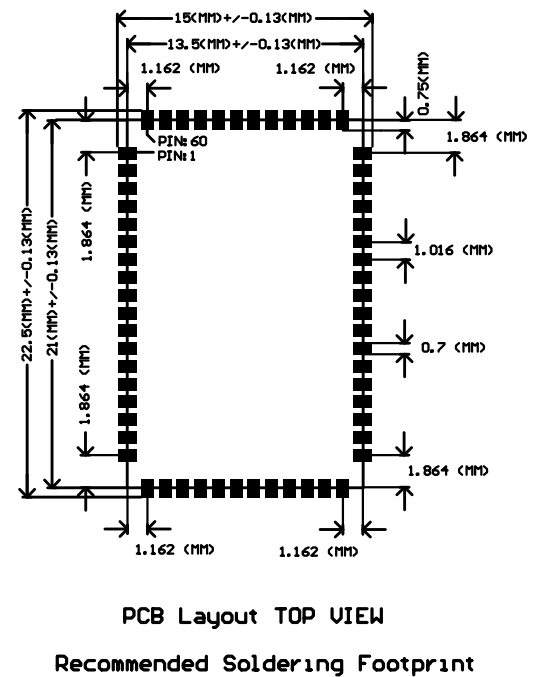
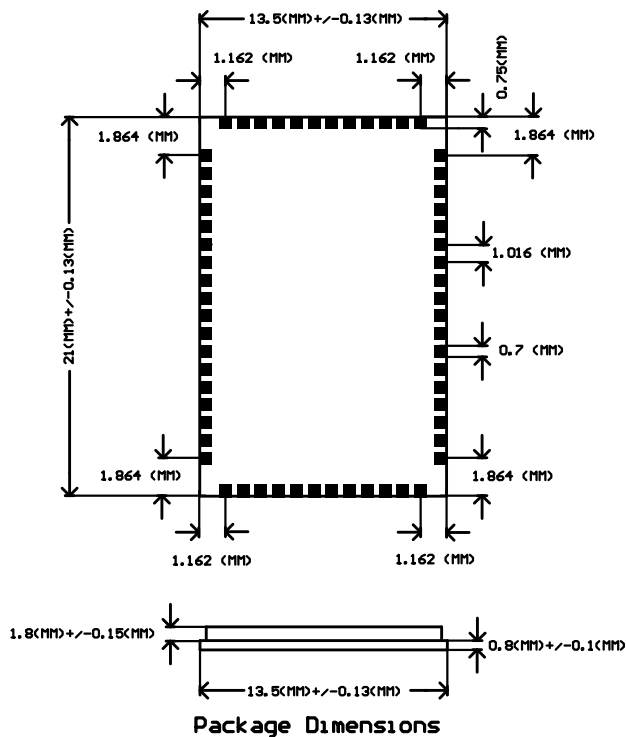

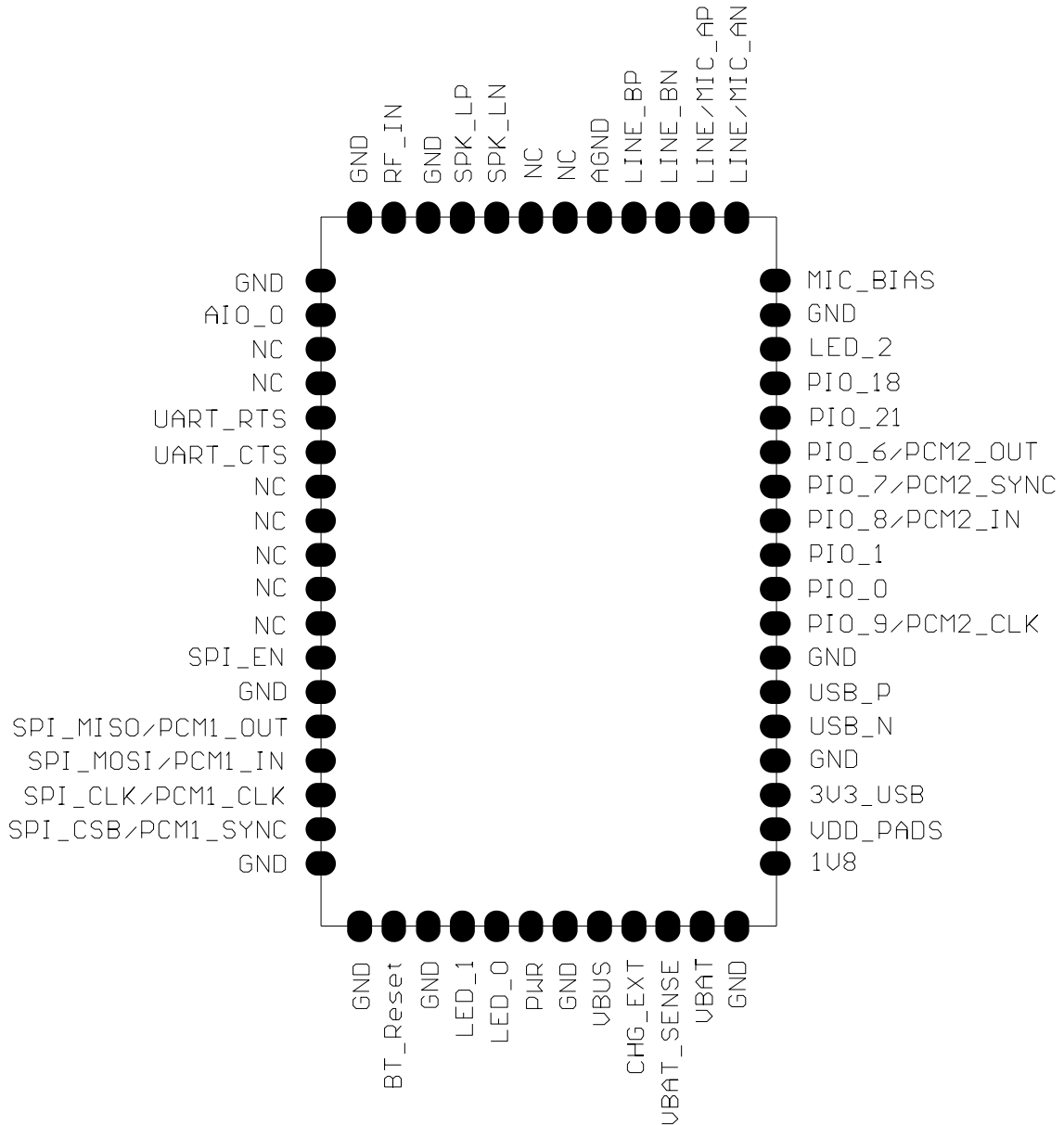



3.1 Pin Description

Pin#	Pin Name	Pad Type	Description
1	GND	Ground	Ground
2	AIO_0	Analogue input/output	Analogue programmable input/ output line
3	NC	NC	NC
4	NC	NC	NC
5	UART_RTS	Bidirectional with strong pull-up	UART request to send active low Alternative function: ■ PIO_16Programmable input/output line
6	UART_CTS	Bidirectional with strong pull-up	UART clear to send active low Alternative function: ■ PIO_17Programmable input/output line
7	NC	NC	NC
8	NC	NC	NC
9	NC	NC	NC
10	NC	NC	NC
11	NC	NC	NC
12	SPI_EN	Input with weak pull-down	SPI/PCM# select input ■ 0=PCM/PIO interface ■ 1=SPI
13	GND	Ground	Ground
14	SPI_MISO/PCM1_OUT	Bidirectional with weak pull-down	SPI data output Alternative function: ■ PIO_3: Programmable input/output line ■ PCM1_OUT: PCM1 synchronous data output ■ I2S1_SD_OUT: I2S1 synchronous data output
15	SPI_MOSI/PCM1_IN	Bidirectional with weak pull-down	SPI data input Alternative function: ■ PIO_2: Programmable input/output line ■ PCM1_IN: PCM1 synchronous data input ■ I2S1_SD_IN:I2S1 synchronous data input
16	SPI_CLK/PCM1_CLK	Bidirectional with weak pull-down	SPI clock Alternative function: ■ PIO_5: Programmable input/output line ■ PCM1_CLK: PCM1 synchronous data clock



			<ul style="list-style-type: none"> ■ I2S1_CLK: I2S1 synchronous data clock
17	SPI_CSB/PCM1_SNYC	Bidirectional with weak pull-down	<p>Chip select for SPI,active low Alternative function:</p> <ul style="list-style-type: none"> ■ PIO_4: Programmable input/output line ■ PCM1_SYNC: PCM1 synchronous data sync ■ I2S1_WS: I2S1 word select
18	GND	Ground	Ground
19	GND	Ground	Ground
20	BT_Reset	Input with strong pull-up	Active LOW>5ms reset
21	GND	Ground	Ground
22	LED_1	Bidirectional	LED driver Alternative function:programmable output PIO(30)
23	LED_0	Bidirectional	LED driver Alternative function:programmable output PIO(29)
24	PWR	CMOS Input	Regulator enable input Can also be sensed as an input Regulator enable and multifunction button.A High input(tolerant to VBAT)enables the on-chip regulators,which can then be latched on internally and the button used as a multifunction input
25	GND	Ground	Ground
26	VBUS	Charge input	Charge input Typically connected charger
27	CHG_EXT	External battery charger control	External battery charger transistor base control when using external charger boost.Otherwise leave unconnected
28	VBAT_SENSE	CMOS Input	Battery charger sense input Connect directly to the battery positive pin
29	VBAT	CMOS Input	Positive supply for BT Module,or battery positive terminal
30	GND	Ground	Ground
31	1V8	Power output	Auxiliary regulator output (1.8V out)
32	VDD_PADS	Power input	Positive supply input for input/output ports
33	3V3_USB	Power output	3.3V bypass linear regulator output



34	GND	Ground	Ground
35	USB_N	Bi-directional	USB data minus
36	USB_P	Bi-directional	USB data plus with selectable internal 1.5kΩ pull-up resistor
37	GND	Ground	Ground
38	PIO_9/PCM2_CLK	Bi-directional with programmable strength internal pull-up/down	Programmable input/output line ■ I2S2_CLK: I2S2 synchronous data clock
39	PIO_0	Bi-directional with programmable strength internal pull-up/down	Programmable input/output line
40	PIO_1	Bi-directional with programmable strength internal pull-up/down	Programmable input/output line
41	PIO_8/PCM2_IN	Bi-directional with programmable strength internal pull-up/down	Programmable input/output line ■ I2S2_SD_IN: I2S2 synchronous data input
42	PIO_7/PCM2_SYNC	Bi-directional with programmable strength internal pull-up/down	Programmable input/output line ■ I2S2_WS: I2S2 word select
43	PIO_6/PCM2_OUT	Bi-directional with programmable strength internal pull-up/down	Programmable input/output line ■ I2S2_SD_OUT: I2S2 synchronous data output
44	PIO_21	Bi-directional with programmable strength internal pull-up/down	Programmable input/output line
45	PIO_18	Bi-directional with programmable strength internal pull-up/down	Programmable input/output line
46	LED_2	Bidirectional	LED driver Alternative function: programmable output PIO(31)
47	GND	Ground	Digital Ground
48	MIC_BIAS	Analogue	Microphone bias
49	LINE/MIC_AN	Analogue in	Microphone input negative, channel A
50	LINE/MIC_AP	Analogue in	Microphone input positive, channel A
51	LINE_BN	Analogue in	Line-in negative, channel B
52	LINE_BP	Analogue in	Line-in positive, channel B
53	AGND	Ground	Analog Ground
54	NC	NC	NC



55	NC	NC	NC
56	SPK_LN	Analogue OUT	Speaker output negative, left
57	SPK_LP	Analogue OUT	Speaker output positive, left
58	GND	Ground	Digital Ground
59	RF_IN	RF	Bluetooth 50Ω transmitter output/receive input
60	GND	Ground	Digital Ground

4. REFERENCE SCHEMATIC

Next page for detail.

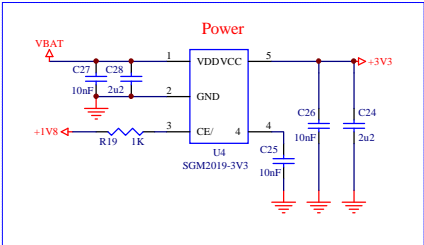
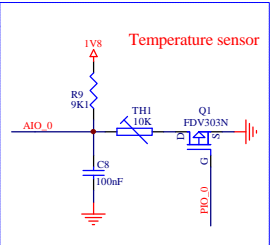
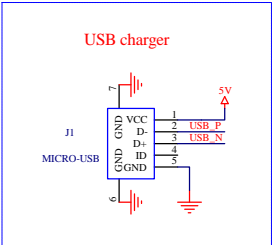
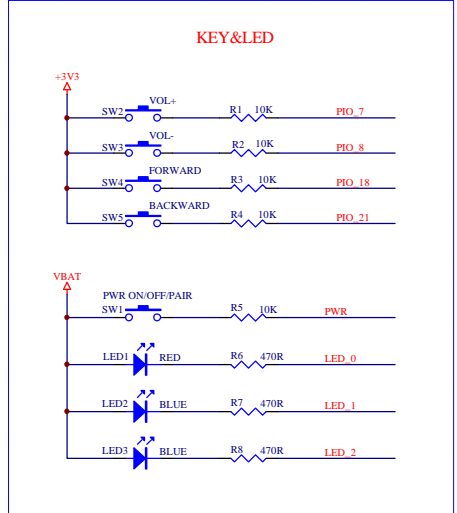
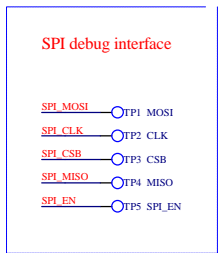
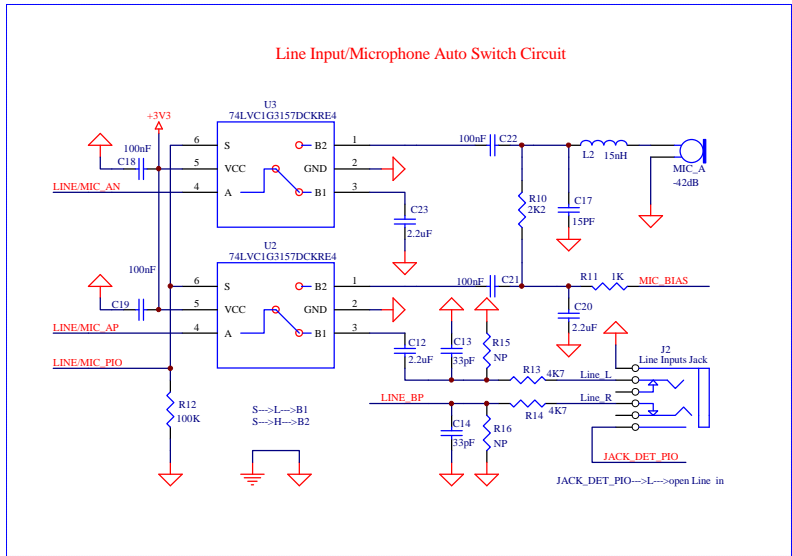
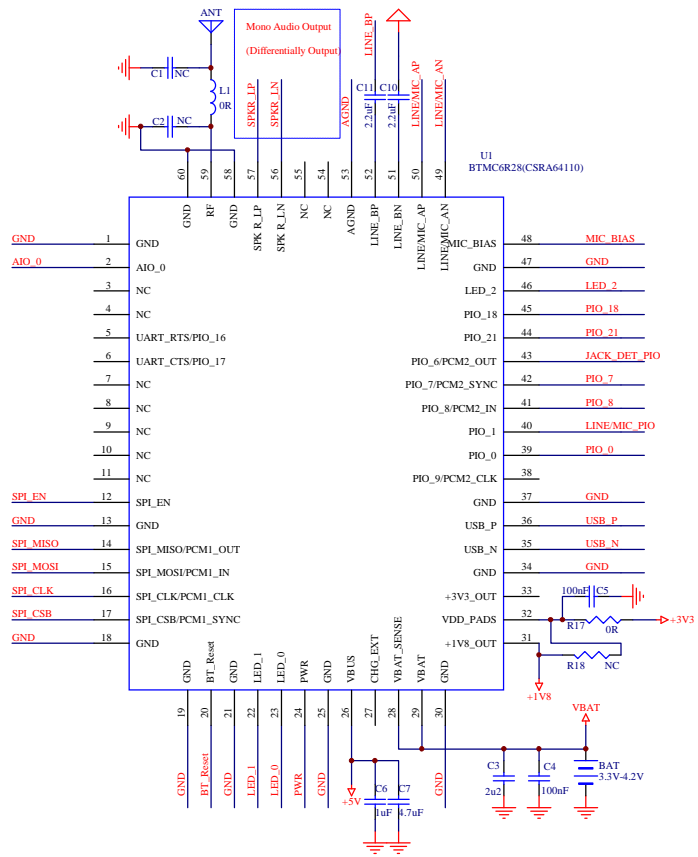



5. PHYSICAL INTERFACE

5.1 Programmable I/O ports

- n The module provide 11 lines of programmable bidirectional I/O, Can configurate to different function by firmware.

5.2 Analogue I/O ports

- n The module has a analogue port AIO_0, typically connections to thermistor for battery pack temperature measurements during charger control.

5.3 LED Driver

- n The module provide 3 synchronized PWM LED driver for RGB leds. Can controlled by firmware. The driver are open-drain outputs, and the LEDs must pull up to positive supply. Refer to the section 4.1

5.4 Audio Interfaces

Audio interface as following features:

- mono analogue audio output through SPK_LP, SPK_LN
- n mono analogue input through LINE/MIC_AN, LINE/MIC_AP, LINE_BN, LINE_BP.
The module is designed for different output, if a single-ended audio output is required, use an external differential to single-ended converter.

5.5 Microphone input

The module contains an independent low-noise microphone bias generator. The microphone bias generator is recommended for biasing electret condenser microphone. section 4.1 is a basing circuit for microphone with a sensitivity between -40~-60db.

5.6 Reset

- n The module is reset from several sources:
 - Reset# pin
 - Power on reset
 - Software configured watch-dog

The Reset pin is an active low reset and is internally filtered using the internal low frequency clock oscillator. Recommended the low period >10ms.
RAM data not available after cold reset.



shows pin states of module on reset

Pin name	I/O type	Reset			
PIO_0	Digital Bidirectional	Strong pull up	PIO_18	Digital Bidirectional	Strong pull down
PIO_1	Digital Bidirectional	Strong pull up	PIO_21	Digital Bidirectional	Weak pull down
PIO_6	Digital Bidirectional	Strong pull down			
PIO_7	Digital Bidirectional	Strong pull down			
PIO_8	Digital Bidirectional	Strong pull up			
PIO_9	Digital Bidirectional	Strong pull down			

5.7 RF Interface

The module integrates a balun filter. A 50ohms load is needed.

5.8 Batter charger

5.8.1 battery charger hardware operating modes

The battery charger hardware is controlled by VM ,it has 5 modes:

Disabled

Trickle charger

Fast charger

Standby:fully charged or float charge

Error:charging input voltage,VCHG is too low.

5.8.2 External charge mode

The external mode is for charging higher capacity batteries using an external bass device.The current is controlled by sinking a varying current into the CHG_EXT pin, and the current is determined by measuring the voltage dorp across a resistor.The max current up to 700mA.

5.9 Serial Interfaces

5.9.1 UART

This is a standard UART interface for communicating with other serial devices. The UART interface provides a simple mechanism for communicating with other serial devices using the RS232 protocol.

When the module is connected to another digital device,UART_RX and UART_TX transfer data between the two devices. The remaining two signals, UART_CTS and UART_RTS, can be used to implement RS232 hardware flow control where both are active low indicators.

Note: The serial port interface(UART)can be used for system debugging. Don't support to use command set for profile function application by UART, such as HFP/A2DP/ AVRCP and so on. These profiles function application can be controlled only by PIO, such as pairing/connect/answer/play/pause/next/previous function application and so on.



5.9.2 SPI

The synchronous serial port interface (SPI) can be used for system debugging. It can also be used for in-system programming for the flash memory within the module. SPI interface uses the SPI_MOSI, SPI_MISO, SPI_CSB and SPI_CLK pins. Testing points for the SPI interface are reserved on board in case that the firmware shall be updated during manufacture.

The module operates as a slave and thus SPI_MISO is an output of the module. SPI_MISO is not in high-impedance state when SPI_CSB is pulled high. Instead, the module outputs 0 if the processor is running and 1 if it is stopped. Thus the module should NOT be connected in a multi-slave arrangement by simple parallel connection of slave SPI_MISO lines.

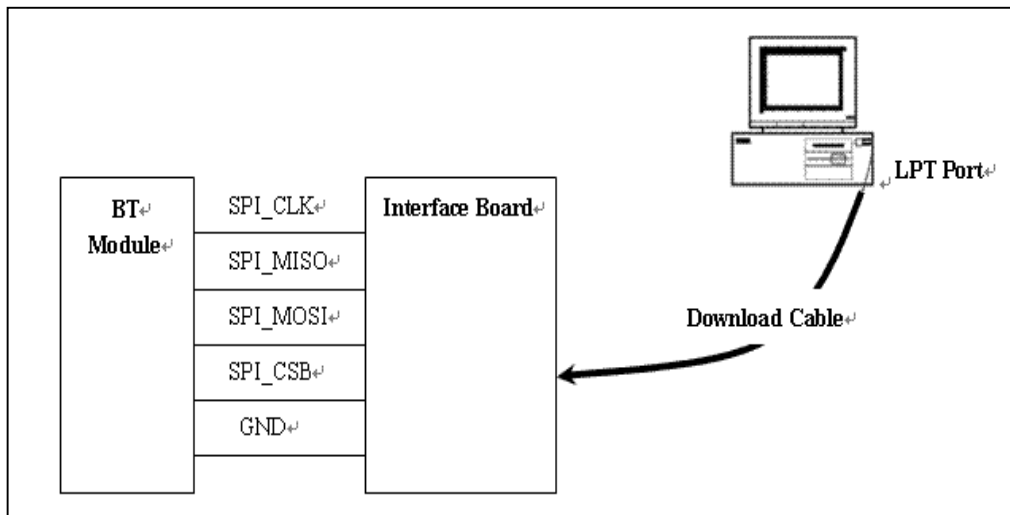



6. ELECTRICAL CHARACTERISTIC

6.1 Absolute Maximum Ratings

Rating	Min	Typ	Max	Unit
Storage temperature range	-40		105	°C
Supply Voltage				
VBAT	-0.4		4.40	V
VBUS	-0.4		5.75	V
VBAT_SENSE	-0.4		4.40	V
PWR	0		4.40	V

6.2 Recommended Operating Conditions

Rating	Min	Typ	Max	Unit
Operating temperature range	-20		70	°C
Supply Voltage				
VBAT	2.80	3.70	4.25	V
VBUS	4.75	5.00	5.75	V
VBAT_SENSE	0	3.70	4.25	V
PWR	0	3.70	4.25	V

6.3 PIO recommended operating conditions

Input Voltage	Min	Typ	Max	Unit
PIOx	1.70	1.80	3.60	V
AIOx	1.30	1.35	1.95	V
LED[0:2]	1.10	3.70	4.30	V
Output	Min	Typ	Max	Unit
PIOx	1.70	1.80	3.60	V
LED[0:2]	0	0		V



Output current with 3.3v supply	Min	Typ	Max	Unit
PIOx(Total output)			5.0	mA

Current with 3.3V Input and Tristate	Min	Typ	Max	Unit
Strong pull up	-150	-40	-10	uA
Strong pull down	10	40	150	uA
Weak pull up	-5	-1.0	-0.33	uA
Weak pull down	0.33	1.0	5.0	uA

6.4 Battery charger

Battery Charger	Min	Typ	Max	Unit
Input voltage, VCHG ^(a)	4.75 / 3.10	5.00	5.75	V

(a) Reduced specification from 3.1 to 4.75. Full specification > 4.75V.

Trickle Charge Mode		Min	Typ	Max	Unit
Charge current I _{trickle} , as percentage of fast charge current		8	10	12	%
V _{fast} rising threshold		-	2.9	-	V
V _{fast} rising threshold trim step size		-	0.1	-	V
V _{fast} falling threshold		-	2.8	-	V
Fast Charge Mode		Min	Typ	Max	Unit
Charge current during constant Current mode, I _{fast}	Max charge setting , headroom(a) > 0.55V	194	200	206	mA
	Min charge setting, headroom(a) > 0.55V		10		mA
Reduced headroom charge current, As a percentage of I _{fast}	Headroom(a)<0.55V	50	-	100	%
charge current step size		-	10	-	mA
V _{float} threshold, calibrated		4.16	4.20	4.24	V
Charge termination current I _{term} , as percentage of I _{fast}		7	10	20	%
Standby Mode		Min	Typ	Max	Unit
Voltage hysteresis on VBAT, V _{hyst}		100	-	150	mV



Error Charge Mode	Min	Typ	Max	Unit
Headroom ^(a) error falling threshold		50		mV

(a) Headroom=VCHG-VBAT

External Charge Mode	Min	Typ	Max	Unit
Fast charge current, I _{fast}	200	-	700	mA
Control current into CHG_EXT	0	-	20	mA
Voltage on CHG_EXT	0		5.75	V
External pass device h _{fe}	-	50	-	-
Sense voltage, between VBAT_SENSE and VBAT at maximum current	195	200	205	mV

6.5 RF characteristics

Receiver		Average	Bluetooth Spec	Transmitter		Average	Bluetooth Spec	Unit
Sensitivity at 0.1 Ber	2402MHz	-85	<=-70	Output Power	2402MHz	5.7	-6~+8	dBm
	2441MHz	-86			2441MHz	5.8		dBm
	2480MHz	-86			2480MHz	5.8		dBm

6.6 Power consumption

Operating Condition		Average Current	Unit
Slave	SCO connection with pocket type HV3	11.4	mA
	eSCO connection with pocket type EV3	11.6	mA
	eSCO connection with pocket type 2EV3	10.2	mA
	Stereo with high quality SBC decode	13.6	mA
Master	SCO connection with pocket type HV3	10.4	mA
	eSCO connection with pocket type EV3	11.3	mA
	eSCO connection with pocket type 2EV3	9.1	mA
	Stereo with high quality SBC decode	14.7	mA



7. REFLOW PROFILE

Reflow number of times: ≤ 2 times

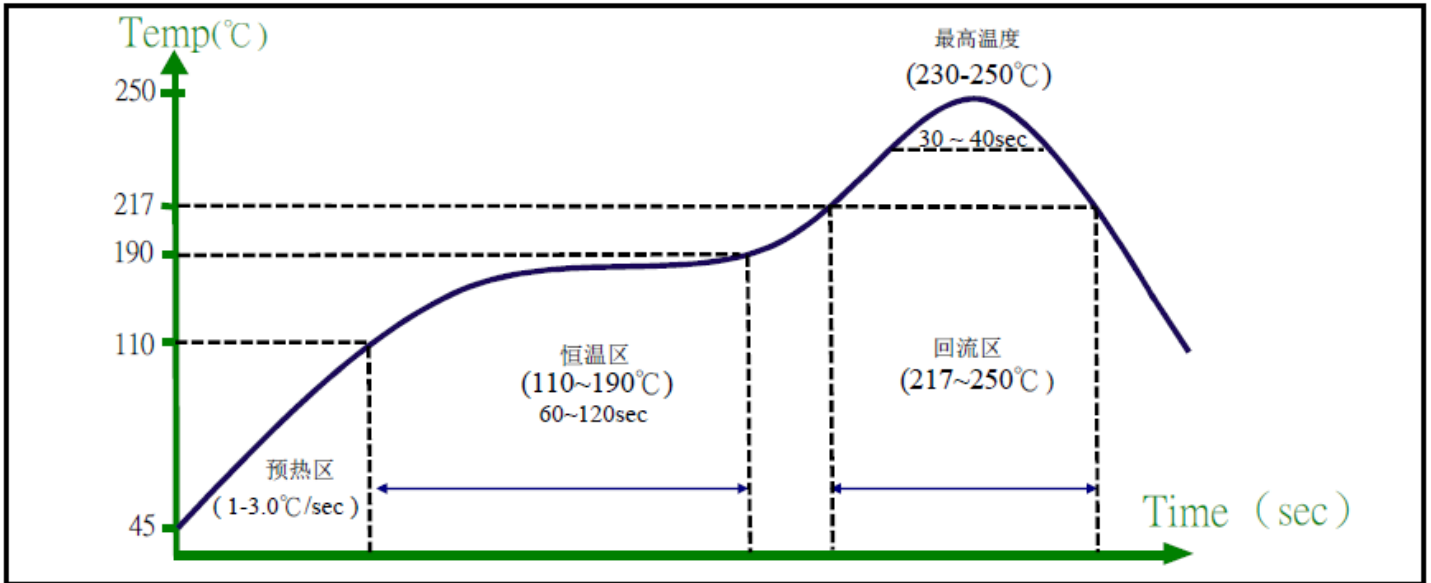

温度范围与要求

1. 预热区: 60-90°C以下, 升温率1 - 3.0°C/sec
2. 恒温区: 110-190°C时间为 60 - 120sec
3. 217°C以上: 30 - 90sec
4. 230°C - 250°C 时间为 30 -40sec
5. 最高温度: 230°C - 250°C.



8. PACKAGING INFORMATION

1. BLUETOOTH® Module: BTMC6R28





Appendix

1.Label Format(Optional)

a. High Temperature Label Recommend

Up Side: Data Matrix(BDA)
Down Side: BDA(the last 6 bit)
Label Format as below:



Label Dimension: 7.3mm * 7.3mm

Optional

Up Side: Data Matrix(BDA)
Down Side: BDA(the last 6 bit)
Label Format as below:



Label Dimension: 12mm * 10mm(or other)

* HD Scanner used for scanning label data matrix

* If require any other label format,must be confirmed with customer

2.Packing(Optional)

a.Tray vacuum



Tray Dimension: 40mm * 35mm

b. Braid vacuum





3.Packing box(Optional)

a.Large packing box

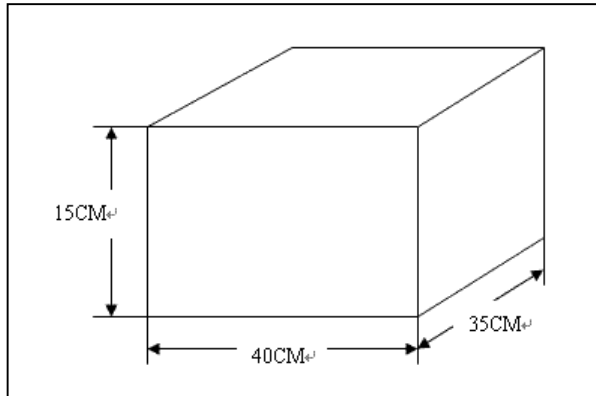

b.Small packing box

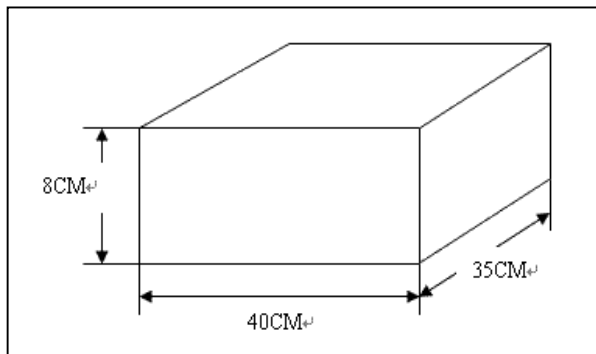

*** If require any other packing,must be confirmed with customer**

All rights are strictly reserved. Any portion of this paper shall not be reproduced, copied, or translated to any other forms without permission from Buddies Technology Limited.