

NPN Epitaxial Planar Transistor

BTN2129E3

Description

The BTN2129E3 is a NPN Darlington transistor, designed for general purpose amplifier and low speed switching application.

Features:

- High current capability
- Low $V_{CE(SAT)}$
- High current gain
- Monolithic construction with built-in base-emitter shunt resistors

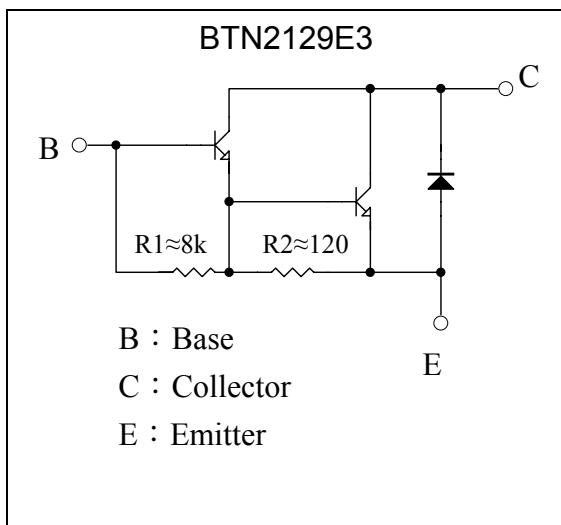
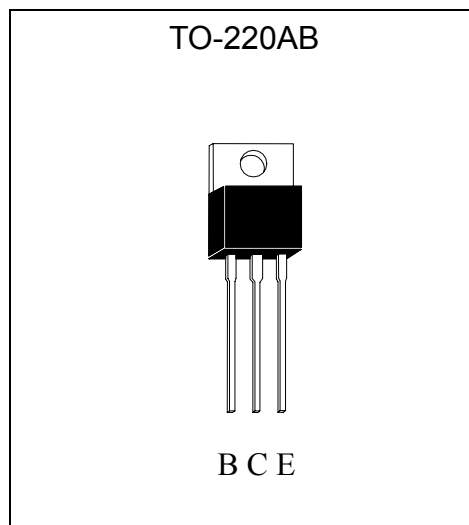
Equivalent Circuit**Outline**

**Absolute Maximum Ratings** (Ta=25°C)

| Parameter | Symbol | Limits | Unit |
|---------------------------|--------------------------|----------|------|
| Collector-Base Voltage | V _{CB0} | 80 | V |
| Collector-Emitter Voltage | V _{CE0} | 50 | V |
| Emitter-Base Voltage | V _{EBO} | 5 | V |
| Collector Current (DC) | I _C | 8 | A |
| Collector Current (Pulse) | I _{CP} | 12 *1 | |
| Power Dissipation | Pd(T _A =25°C) | 2 | W |
| | Pd(T _C =25°C) | 50 | |
| Junction Temperature | T _j | 150 | °C |
| Storage Temperature | T _{stg} | -55~+150 | °C |

Note : *1. Single Pulse Pw=100ms

Characteristics (Ta=25°C)

| Symbol | Min. | Typ. | Max. | Unit | Test Conditions |
|-------------------------|------|------|------|------|--|
| BV _{CE0} | 50 | - | - | V | I _C =1mA, I _B =0 |
| I _{CE0} | - | - | 10 | μA | V _{CE} =40V, I _E =0 |
| I _{CB0} | - | - | 10 | μA | V _{CB} =80V, I _E =0 |
| I _{EBO} | - | - | 2 | mA | V _{EB} =5V, I _C =0 |
| *V _{CE(sat)} 1 | - | - | 1.3 | V | I _C =3A, I _B =12mA |
| *V _{CE(sat)} 2 | - | - | 1.5 | V | I _C =5A, I _B =20mA |
| *V _{BE(sat)} | - | - | 2.1 | V | I _C =3A, I _B =12mA |
| *V _{BE(on)} 1 | - | - | 2 | V | V _{CE} =3V, I _C =3A |
| *V _{BE(on)} 2 | - | - | 2.1 | V | V _{CE} =4V, I _C =4A |
| *h _{FE} 1 | 500 | - | - | - | V _{CE} =3V, I _C =500mA |
| *h _{FE} 2 | 2 | - | 20 | K | V _{CE} =3V, I _C =3A |
| *h _{FE} 3 | 2 | - | - | K | V _{CE} =4V, I _C =4A |

*Pulse Test : Pulse Width ≤380μs, Duty Cycle≤2%



Characteristic Curves

Current Gain vs Collector Current

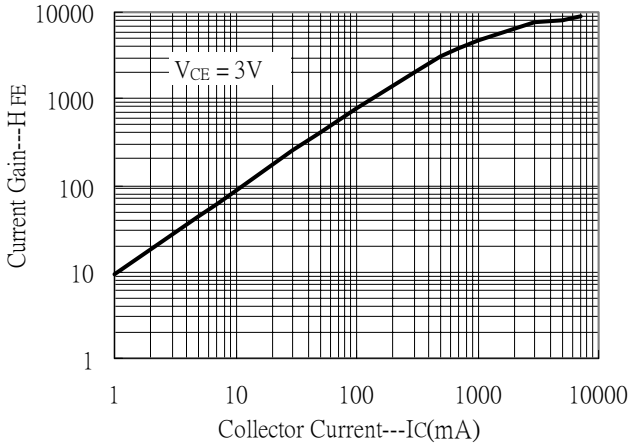

Saturation Voltage vs Collector Current

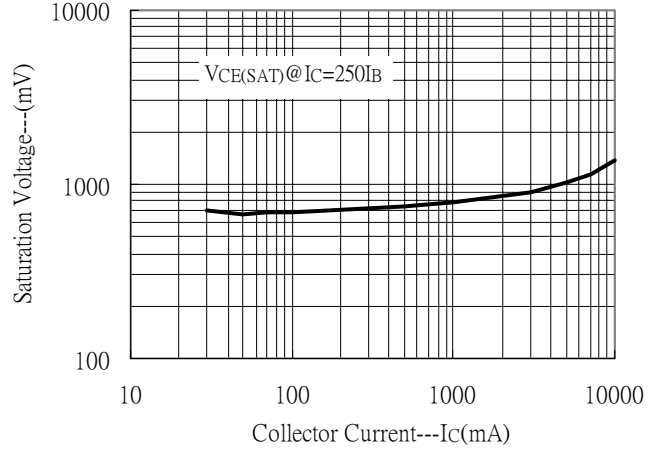

Saturation Voltage vs Collector Current

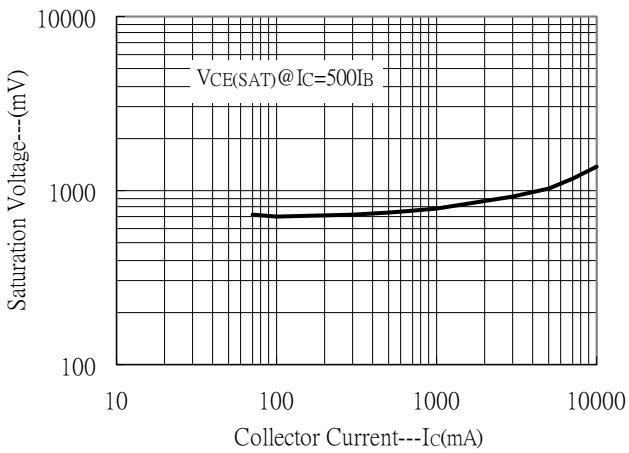

Saturation Voltage vs Collector Current

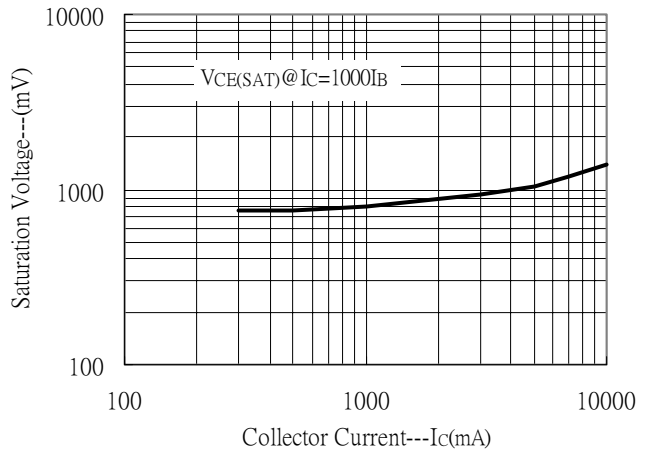

Saturation Voltage vs Collector Current

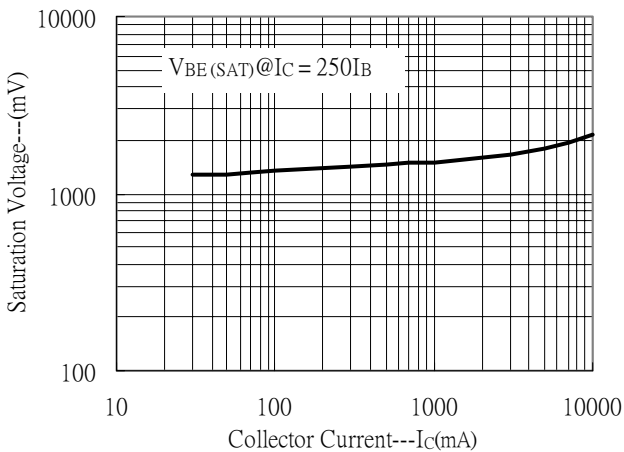

Saturation Voltage vs Collector Current

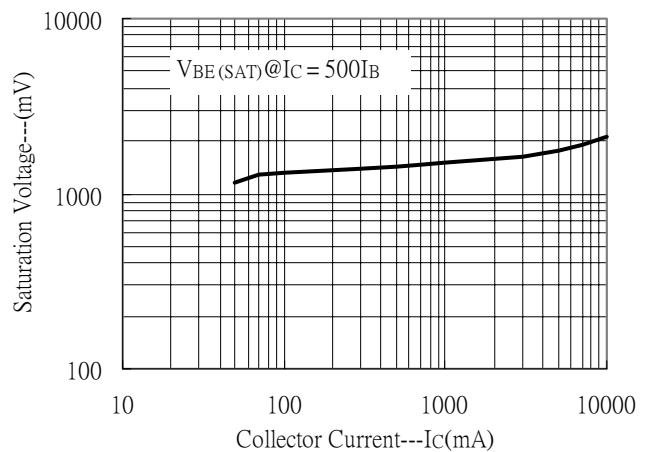



Characteristic Curves(Cont.)

On voltage vs Collector Current

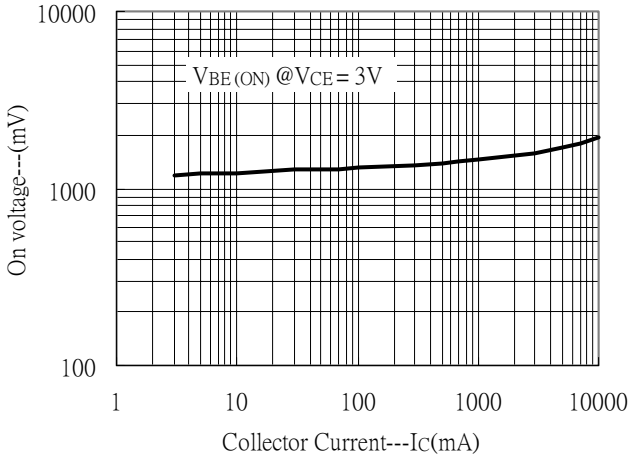

Power Derating Curve

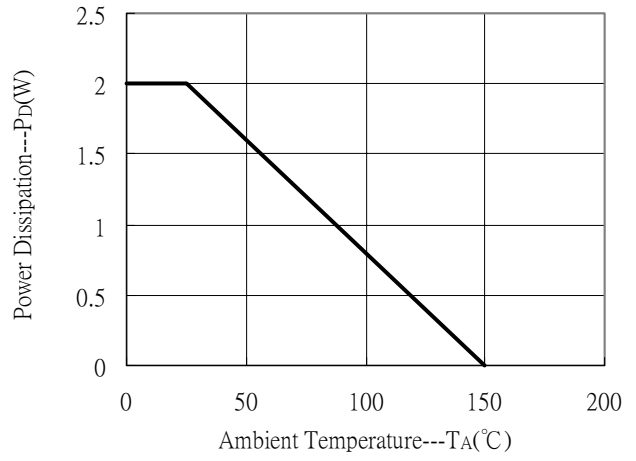

Power Derating Curve

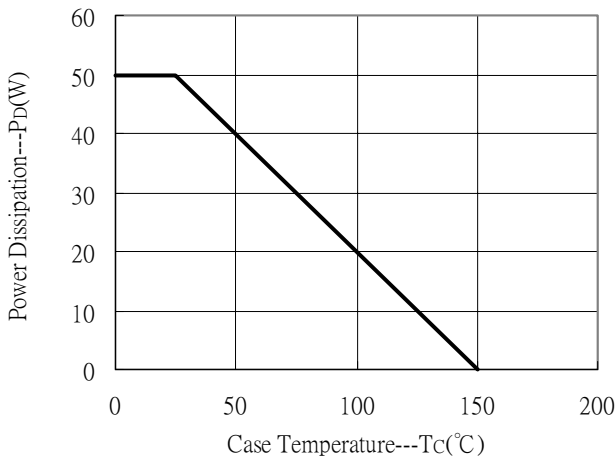

TO-220AB Dimension

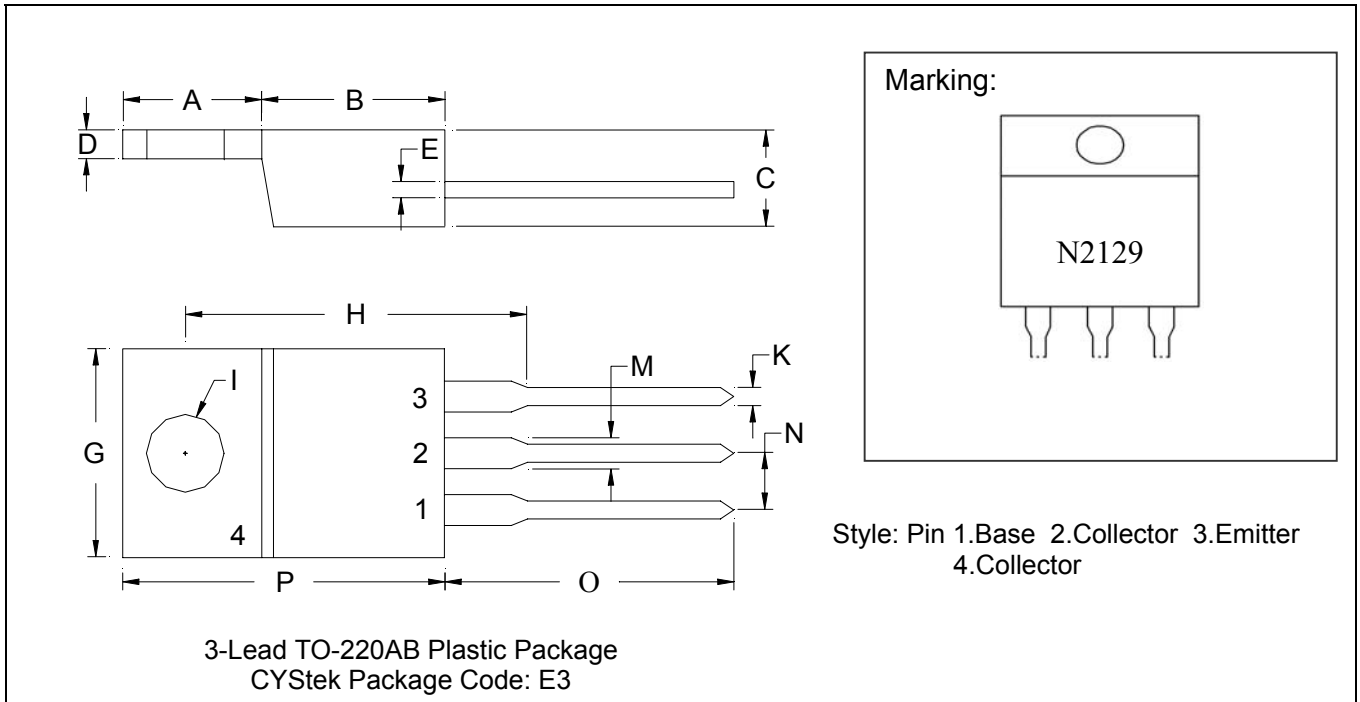

*: Typical

| DIM | Inches | | Millimeters | | DIM | Inches | | Millimeters | |
|-----|--------|---------|-------------|--------|-----|--------|---------|-------------|-------|
| | Min. | Max. | Min. | Max. | | Min. | Max. | Min. | Max. |
| A | 0.2197 | 0.2949 | 5.58 | 7.49 | I | - | *0.1508 | - | *3.83 |
| B | 0.3299 | 0.3504 | 8.38 | 8.90 | K | 0.0295 | 0.0374 | 0.75 | 0.95 |
| C | 0.1732 | 0.185 | 4.40 | 4.70 | M | 0.0449 | 0.0551 | 1.14 | 1.40 |
| D | 0.0453 | 0.0547 | 1.15 | 1.39 | N | - | *0.1000 | - | *2.54 |
| E | 0.0138 | 0.0236 | 0.35 | 0.60 | O | 0.5000 | 0.5618 | 12.70 | 14.27 |
| G | 0.3803 | 0.4047 | 9.66 | 10.28 | P | 0.5701 | 0.6248 | 14.48 | 15.87 |
| H | - | *0.6398 | - | *16.25 | | | | | |

Notes: 1.Controlling dimension: millimeters.
 2.Maximum lead thickness includes lead finish thickness, and minimum lead thickness is the minimum thickness of base material.
 3.If there is any question with packing specification or packing method, please contact your local CYStek sales office.

Material:

- Lead: 42 Alloy ; solder plating
- Mold Compound: Epoxy resin family, flammability solid burning class: UL94V-0

Important Notice:

- All rights are reserved. Reproduction in whole or in part is prohibited without the prior written approval of CYStek.
- CYStek reserves the right to make changes to its products without notice.
- CYStek **semiconductor products are not warranted to be suitable for use in Life-Support Applications, or systems.**
- CYStek assumes no liability for any consequence of customer product design, infringement of patents, or application assistance.