

**High Frequency NPN Switching Transistor**

# BTN2369S3

## Description

- High transition frequency,  $f_T=500\text{MHz}(\text{min})$
- High current,  $I_{C(\text{max})}=200\text{mA}$
- Low saturation voltage,  $V_{CE(\text{SAT})}=0.3\text{V}(\text{max})$
- Pb-free lead plating package

## Symbol

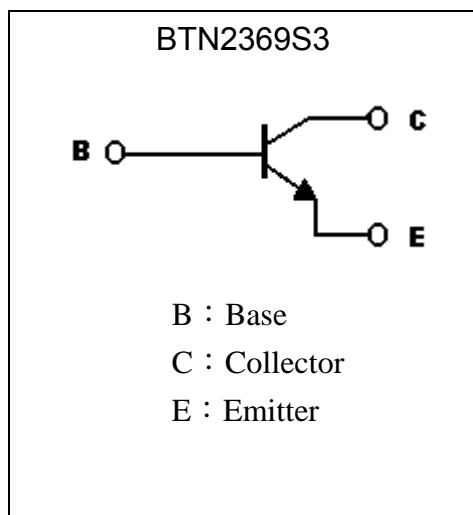

## Outline

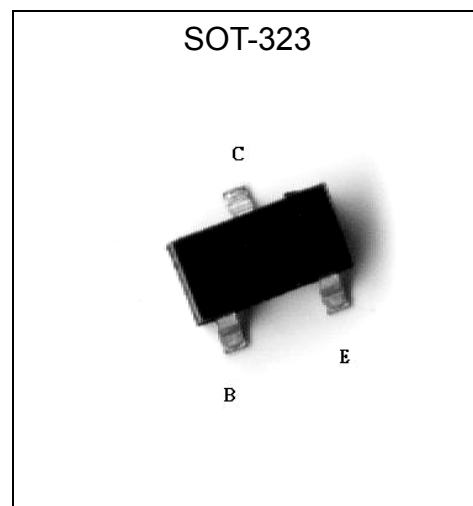

## Ordering Information

Device	Package	Shipping
BTN2369S3-0-T1-G	SOT-323 (Pb-free and halogen-free package)	3000 pcs / Tape & Reel

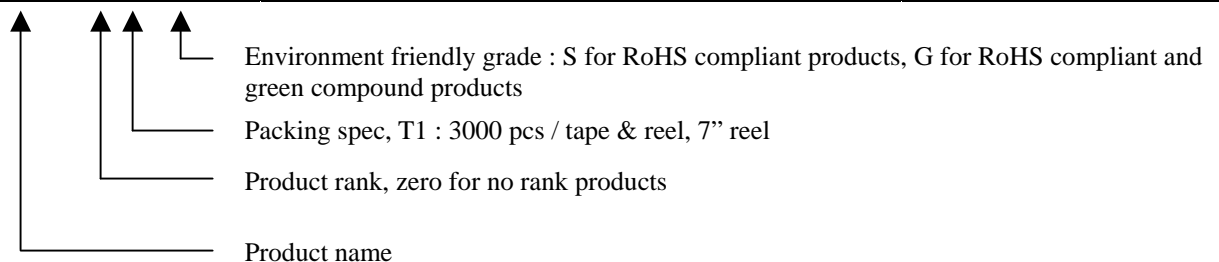

**Absolute Maximum Ratings** (Ta=25°C)

Parameter	Symbol	Limits	Unit
Collector-Base Voltage	V <sub>CB0</sub>	40	V
Collector-Emitter Voltage	V <sub>CEO</sub>	15	V
Emitter-Base Voltage	V <sub>EBO</sub>	4.5	V
Collector Current (DC)	I <sub>C</sub>	200	mA
Power Dissipation	P <sub>d</sub>	300	mW
Junction Temperature	T <sub>j</sub>	150	°C
Storage Temperature	T <sub>stg</sub>	-55~+150	°C

Note: When mounted on FR-4 PCB with area measuring 50×50×1.6 mm

**Characteristics** (Ta=25°C)

Symbol	Min.	Typ.	Max.	Unit	Test Conditions
BV <sub>CB0</sub>	40	-	-	V	I <sub>C</sub> =50μA
BV <sub>CEO</sub>	15	-	-	V	I <sub>C</sub> =1mA
BV <sub>EBO</sub>	4.5	-	-	V	I <sub>E</sub> =50μA
I <sub>CB0</sub>	-	-	100	nA	V <sub>CB</sub> =40V
I <sub>EBO</sub>	-	-	100	nA	V <sub>EB</sub> =4.5V
*V <sub>CE(sat)</sub> 1	-	-	250	mV	I <sub>C</sub> =10mA, I <sub>B</sub> =1mA
*V <sub>CE(sat)</sub> 2	-	-	300	mV	I <sub>C</sub> =20mA, I <sub>B</sub> =1mA
*V <sub>BE(sat)</sub> 1	700	-	850	mV	I <sub>C</sub> =10mA, I <sub>B</sub> =1mA
*V <sub>BE(sat)</sub> 2	-	-	1	V	I <sub>C</sub> =20mA, I <sub>B</sub> =1mA
*h <sub>FE</sub> 1	70	-	140	-	V <sub>CE</sub> =6V, I <sub>C</sub> =1mA
*h <sub>FE</sub> 2	70	-	140	-	V <sub>CE</sub> =1V, I <sub>C</sub> =10mA
*h <sub>FE</sub> 3	20	-	-	-	V <sub>CE</sub> =2V, I <sub>C</sub> =100mA
f <sub>T</sub>	500	-	-	MHz	V <sub>CE</sub> =10V, I <sub>C</sub> =10mA, f=100MHz
C <sub>ob</sub>	-	-	4	pF	V <sub>CB</sub> =5V, f=1MHz

\*Pulse Test: Pulse Width ≤380μs, Duty Cycle≤2%

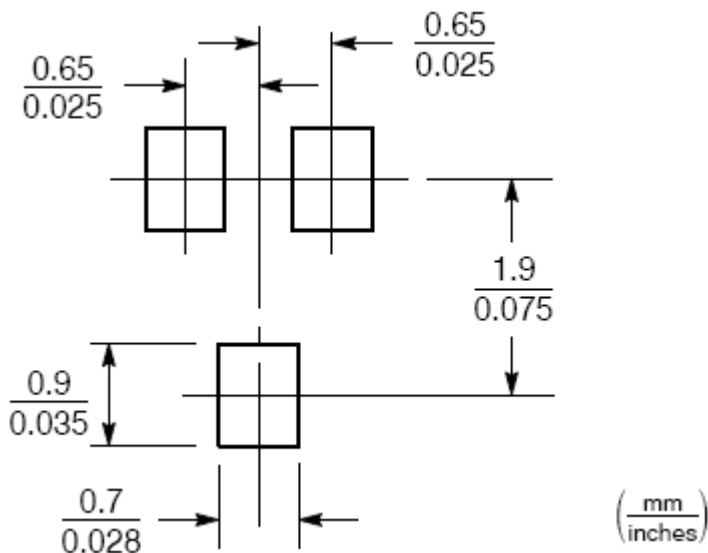
**Recommended Soldering Footprint**

## Typical Characteristics

Current Gain vs Collector Current

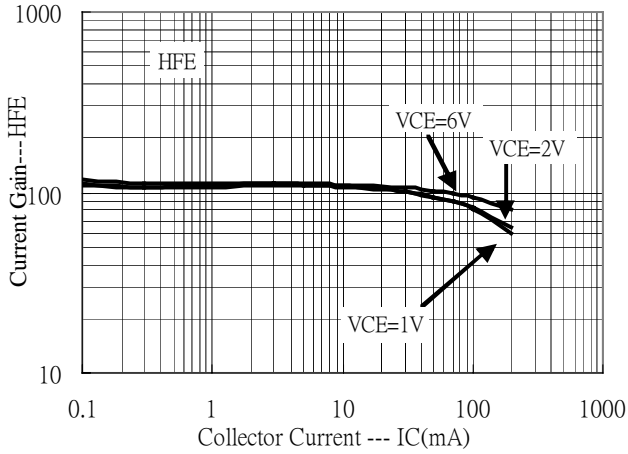

Saturation Voltage vs Collector Current

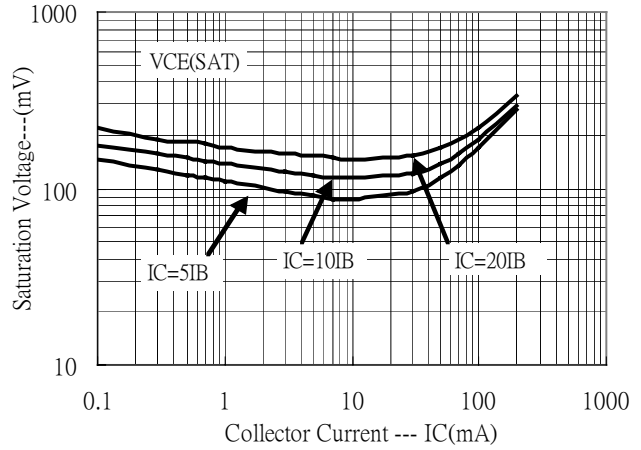

Saturation Voltage vs Collector Current

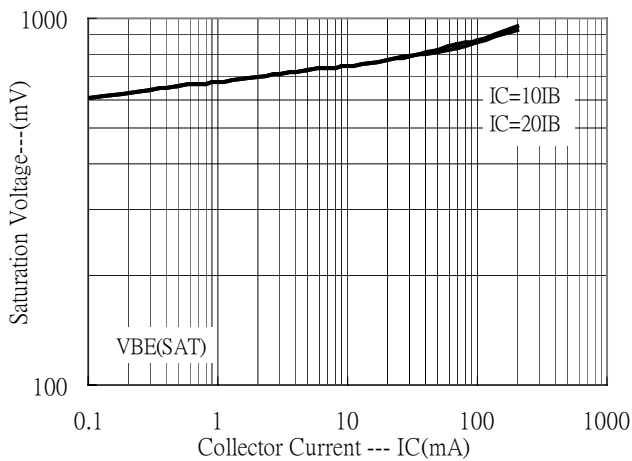

Capacitance Characteristics

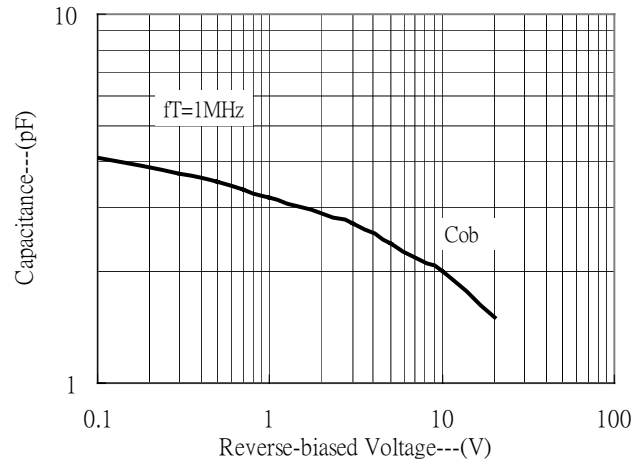

Power Derating Curve

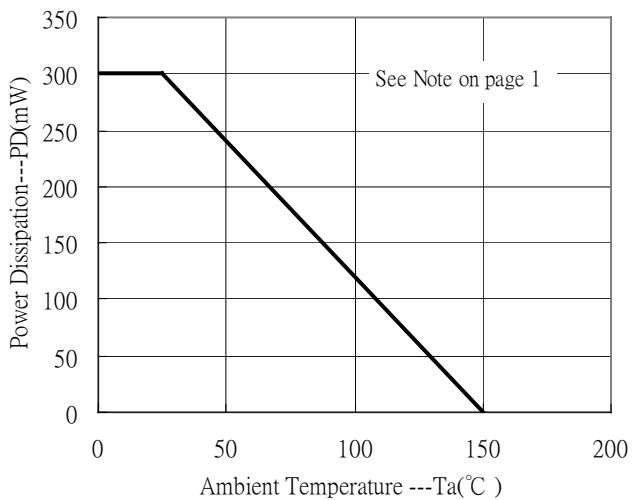

**Reel Dimension**

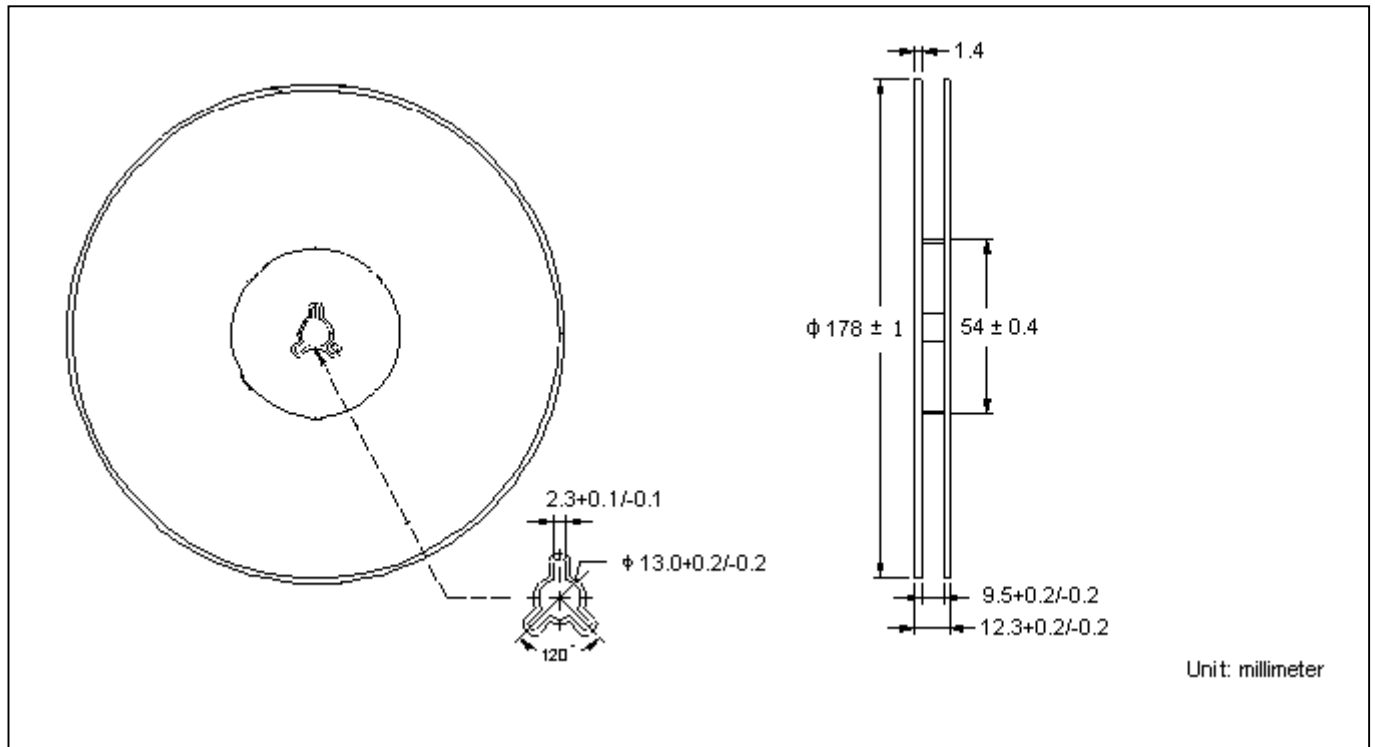

**Carrier Tape Dimension**

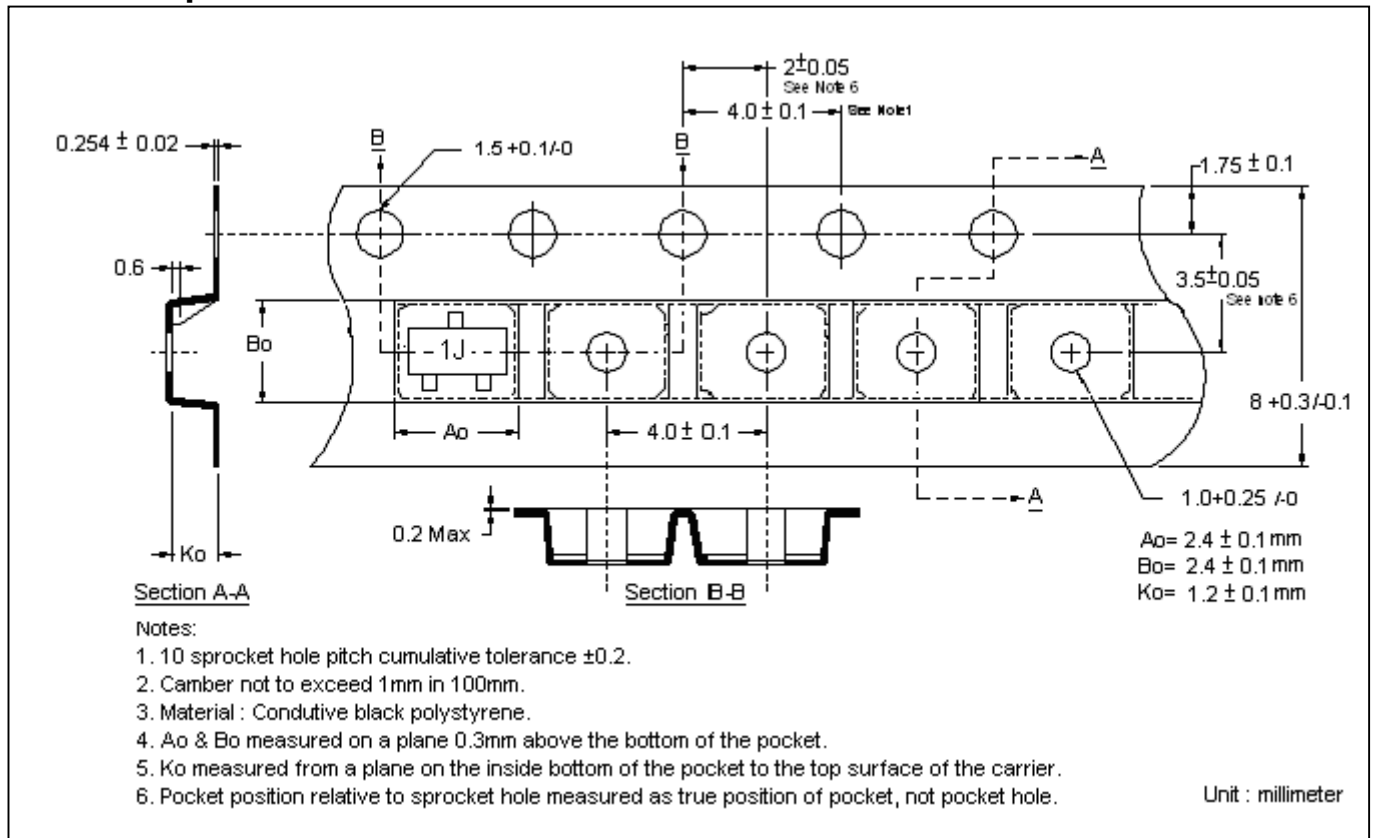

**Recommended wave soldering condition**

Product	Peak Temperature	Soldering Time
Pb-free devices	260 +0/-5 °C	5 +1/-1 seconds

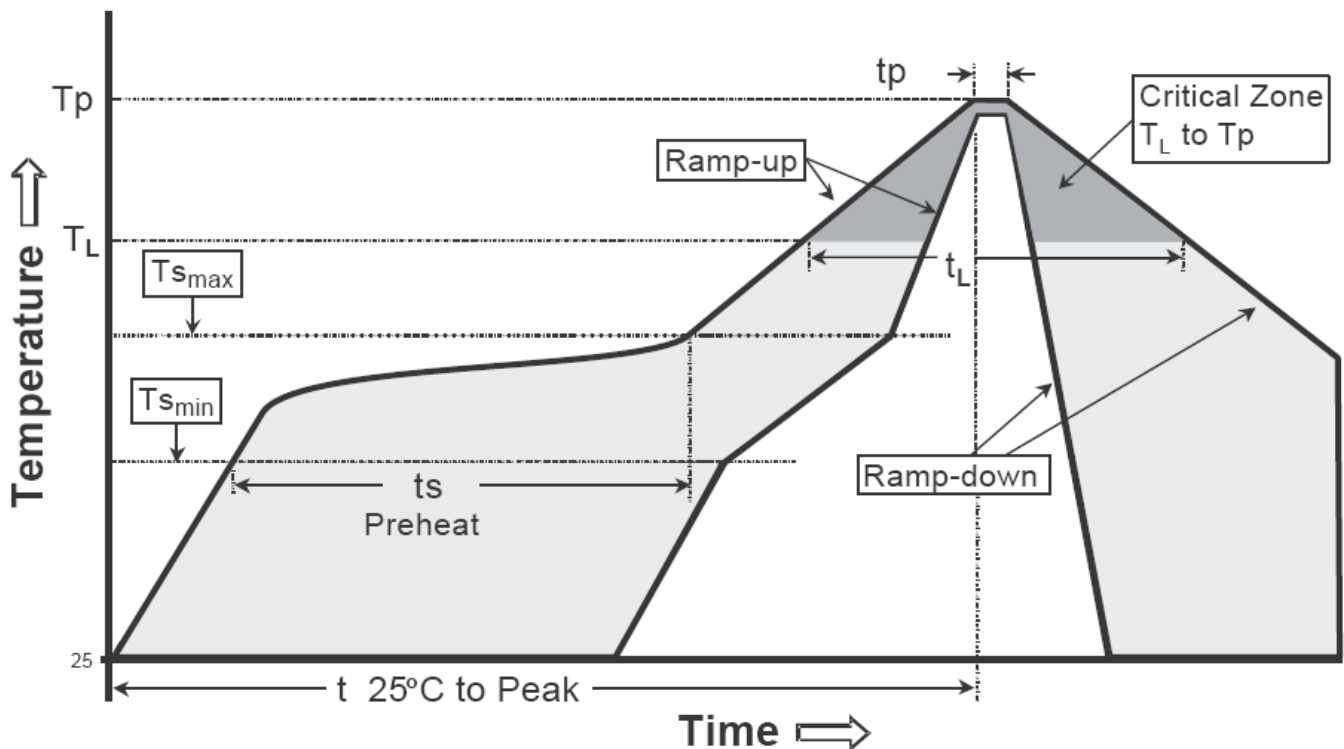
**Recommended temperature profile for IR reflow**

Profile feature	Sn-Pb eutectic Assembly	Pb-free Assembly
Average ramp-up rate (T <sub>smax</sub> to T <sub>p</sub> )	3°C/second max.	3°C/second max.
Preheat		
-Temperature Min(T <sub>s min</sub> )	100°C	150°C
-Temperature Max(T <sub>s max</sub> )	150°C	200°C
-Time(t <sub>s min</sub> to t <sub>s max</sub> )	60-120 seconds	60-180 seconds
Time maintained above:		
-Temperature (T <sub>L</sub> )	183°C	217°C
- Time (t <sub>L</sub> )	60-150 seconds	60-150 seconds
Peak Temperature(T <sub>P</sub> )	240 +0/-5 °C	260 +0/-5 °C
Time within 5°C of actual peak temperature(tp)	10-30 seconds	20-40 seconds
Ramp down rate	6°C/second max.	6°C/second max.
Time 25 °C to peak temperature	6 minutes max.	8 minutes max.

Note : All temperatures refer to topside of the package, measured on the package body surface.

## SOT-323 Dimension

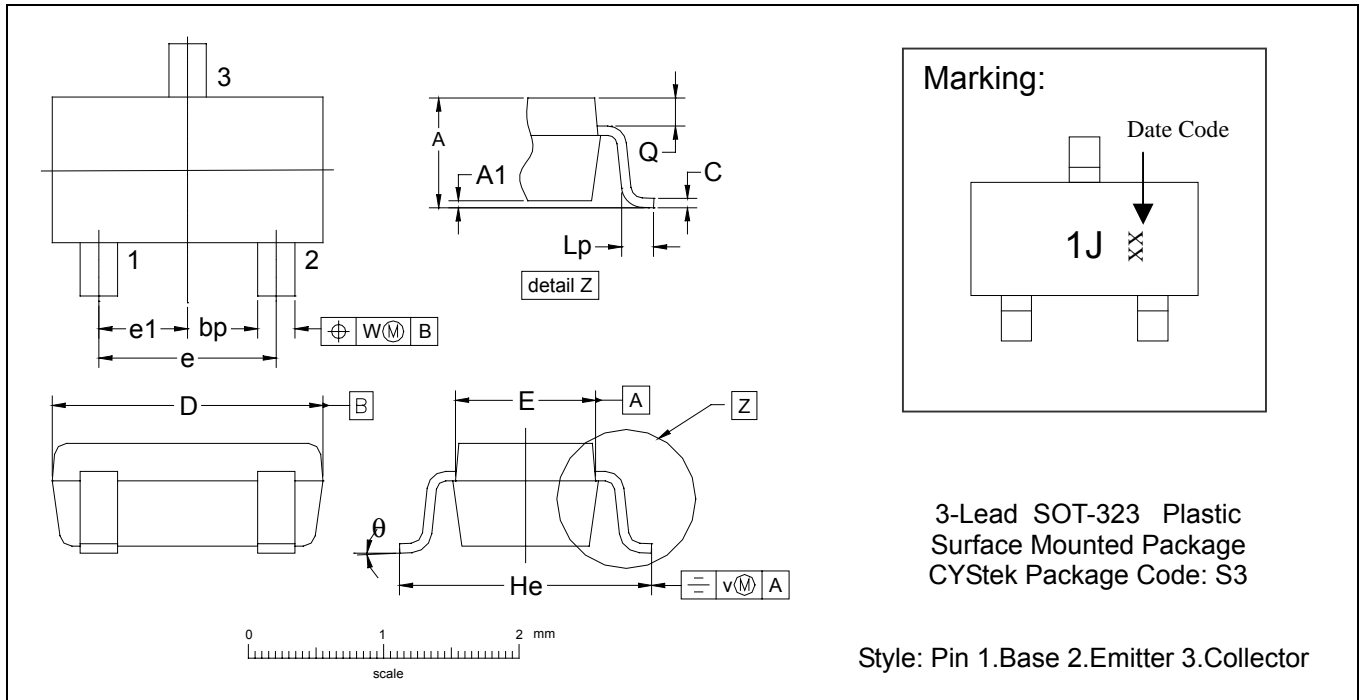

\*: Typical

DIM	Inches		Millimeters		DIM	Inches		Millimeters	
	Min.	Max.	Min.	Max.		Min.	Max.	Min.	Max.
A	0.0315	0.0433	0.80	1.10	e1	0.0256*		0.65*	
A1	0.0000	0.0039	0.00	0.10	He	0.0846	0.0965	2.15	2.45
bp	0.0078	0.0157	0.20	0.40	Lp	0.0105	0.0181	0.26	0.46
C	0.0031	0.0059	0.08	0.15	Q	0.0051	0.0091	0.13	0.23
D	0.0709	0.0866	1.80	2.20	v	0.0079	-	0.2	-
E	0.0453	0.0531	1.15	1.35	w	0.0079	-	0.2	-
e	0.0472	0.0551	1.20	1.40	θ	0°	8°	0°	8°

Notes: 1.Controlling dimension: millimeters.  
 2.Maximum lead thickness includes lead finish thickness, and minimum lead thickness is the minimum thickness of base material.  
 3.If there is any question with packing specification or packing method, please contact your local CYStek sales office.

**Material:**

- Lead: Pure tin plated
- Mold Compound: Epoxy resin family, flammability solid burning class: UL94V-0

**Important Notice:**

- All rights are reserved. Reproduction in whole or in part is prohibited without the prior written approval of CYStek.
- CYStek reserves the right to make changes to its products without notice.
- CYStek **semiconductor products are not warranted to be suitable for use in Life-Support Applications, or systems.**
- CYStek assumes no liability for any consequence of customer product design, infringement of patents, or application assistance.