

**Low Vcesat NPN Epitaxial Planar Transistor**

# BTN3501F3

**Features**

- Low  $V_{CE(sat)}$
- High  $BV_{CEO}$
- Excellent current gain characteristics
- Pb-free package

**Symbol**

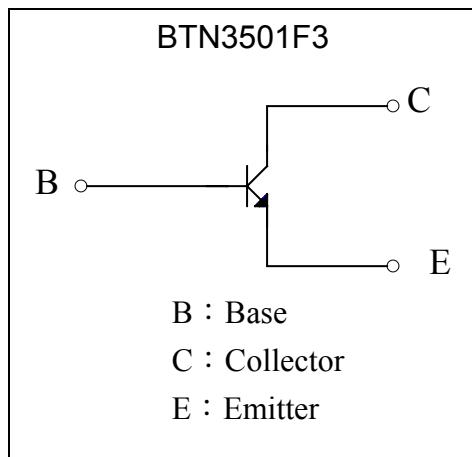

**Outline**

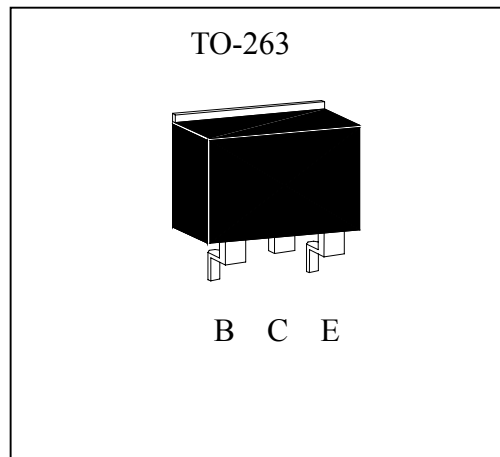

**Absolute Maximum Ratings** ( $T_a=25^{\circ}C$ )

Parameter	Symbol	Limits	Unit
Collector-Base Voltage	$V_{CB0}$	80	V
Collector-Emitter Voltage	$V_{CE0}$	80	V
Emitter-Base Voltage	$V_{EB0}$	6	V
Collector Current (DC)	$I_C$	10	A
Collector Current (Pulse)	$I_{CP}$	20 (Note 1)	
Power Dissipation @ $T_A=25^{\circ}C$	$P_D$	2	W
Power Dissipation @ $T_C=25^{\circ}C$		60	
Thermal Resistance, Junction to Ambient	$R_{\theta JA}$	62.5	$^{\circ}C/W$
Thermal Resistance, Junction to Case	$R_{\theta JC}$	2.08	$^{\circ}C/W$
Junction Temperature	$T_j$	150	$^{\circ}C$
Storage Temperature	$T_{stg}$	-55~+150	$^{\circ}C$

Note : 1. Single Pulse ,  $P_w \leq 380\mu s, Duty \leq 2\%$ .



**Characteristics (Ta=25°C)**

Symbol	Min.	Typ.	Max.	Unit	Test Conditions
$BV_{CEO(SUS)}$	80	-	-	V	$I_C=30mA, I_B=0$
$I_{CES}$	-	-	10	$\mu A$	$V_{CE}=80V, V_{BE}=0$
$I_{EBO}$	-	-	50	$\mu A$	$V_{EB}=5V, I_C=0$
* $V_{CE(sat)}$	-	0.3	0.6	V	$I_C=8A, I_B=0.4A$
* $V_{BE(sat)}$	-	1.0	1.5	V	$I_C=8A, I_B=0.8A$
* $h_{FE}$	60	-	-	-	$V_{CE}=1V, I_C=2A$
* $h_{FE}$	40	-	-	-	$V_{CE}=1V, I_C=4A$
$f_T$	-	50	-	MHz	$V_{CE}=6V, I_C=500mA, f=20MHz$
Cob	-	130	-	pF	$V_{CB}=10V, f=1MHz$

\*Pulse Test : Pulse Width  $\leq 380\mu s$ , Duty Cycle  $\leq 2\%$

**Ordering Information**

Device	Package	Shipping	Marking
BTN3501F3	TO-263 (Pb-free)	800 pcs / Tape & Reel	N3501

**Characteristic Curves**

Grounded Emitter Output Characteristics

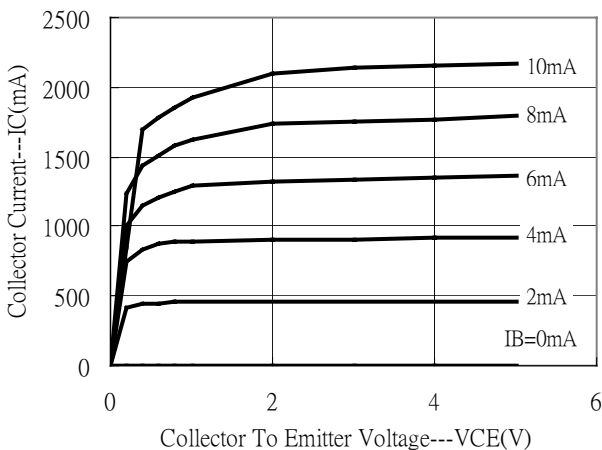

Grounded Emitter Output Characteristics

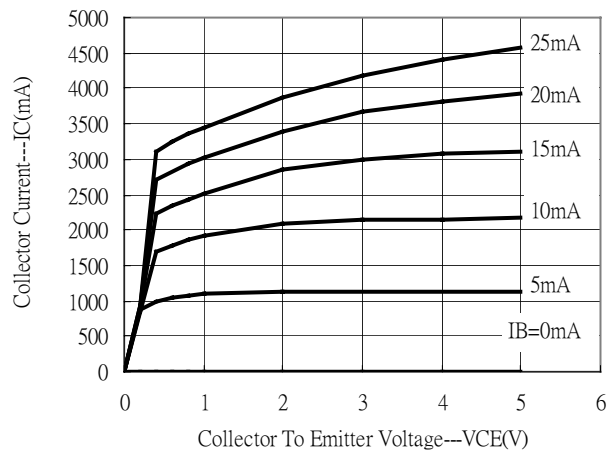

**Characteristic Curves(Cont.)**

Grounded Emitter Output Characteristics

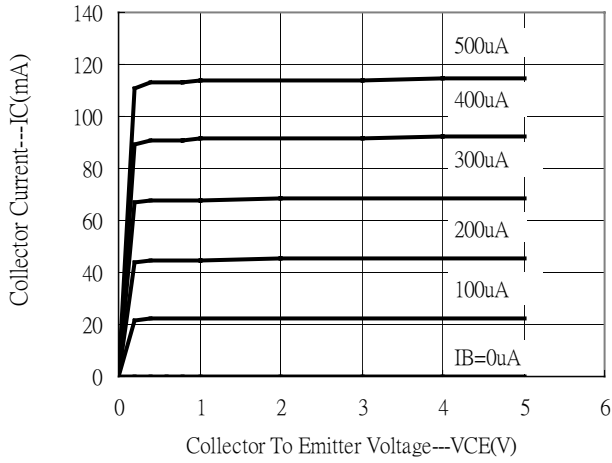

Grounded Emitter Output Characteristics

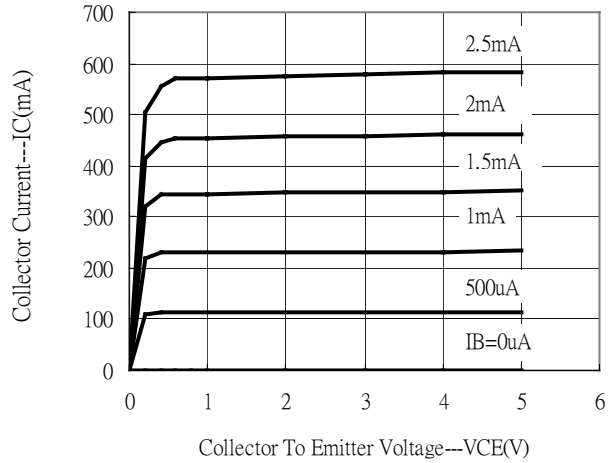

Current Gain vs Collector Current

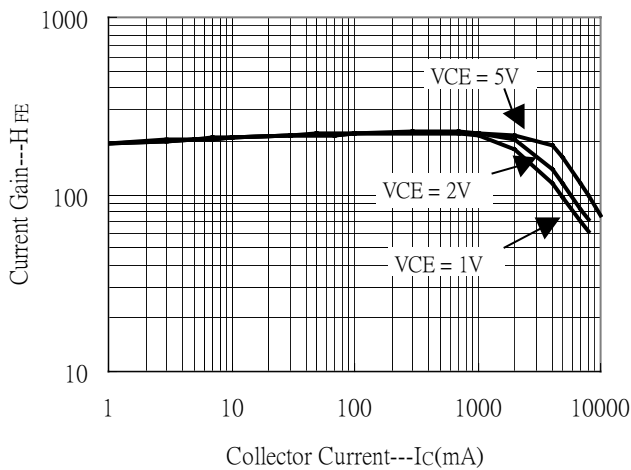

Saturation Voltage vs Collector Current

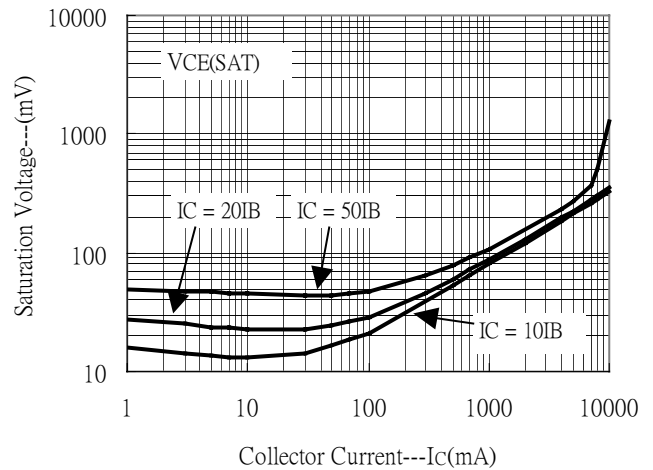

Saturation Voltage vs Collector Current

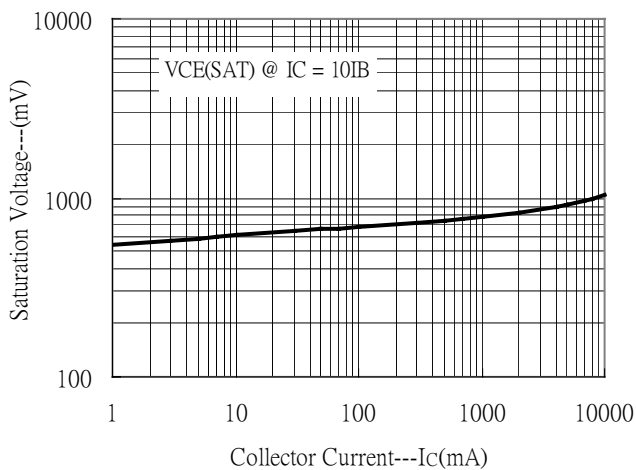

Power Derating Curve

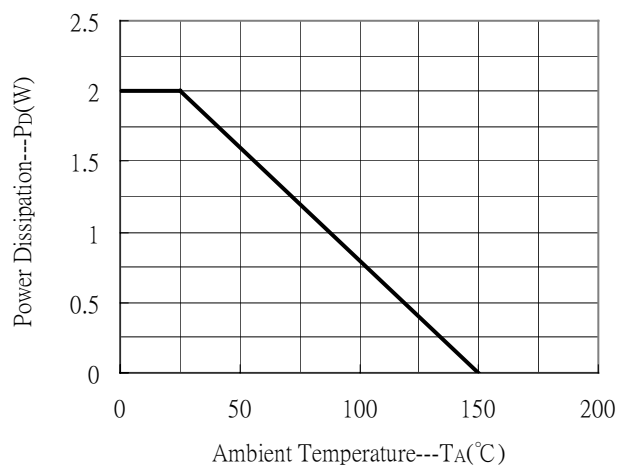



### Characteristic Curves(Cont.)

Power Derating Curve

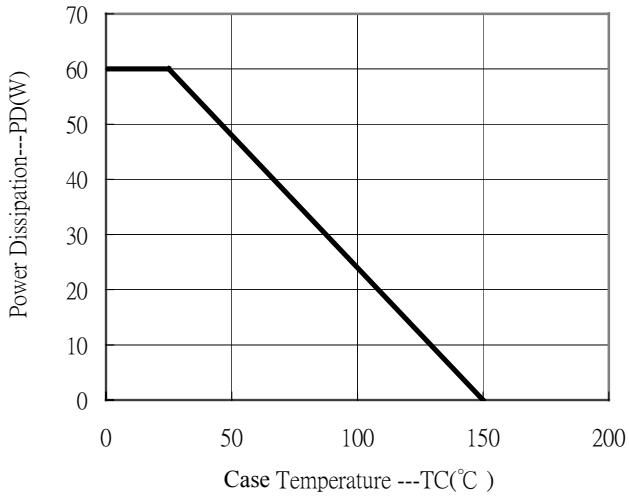

**Reel Dimension**

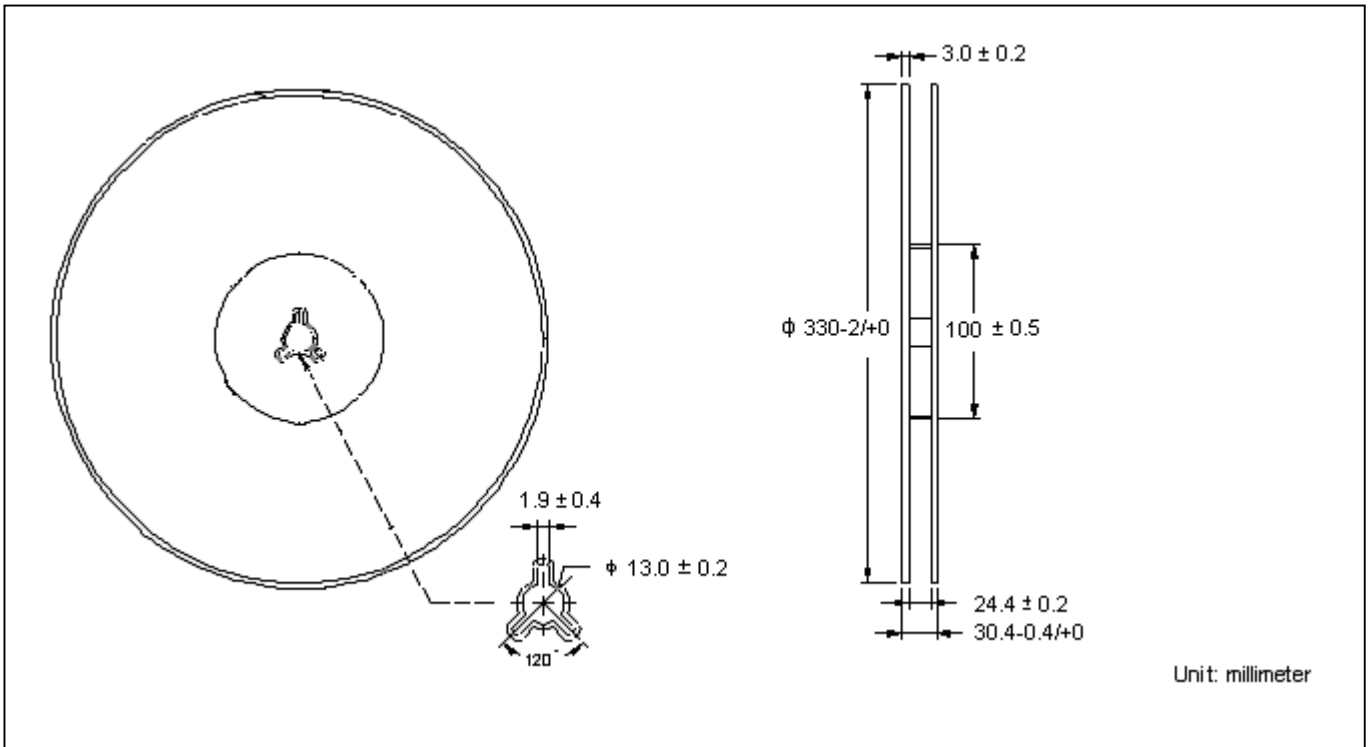

**Carrier Tape Dimension**

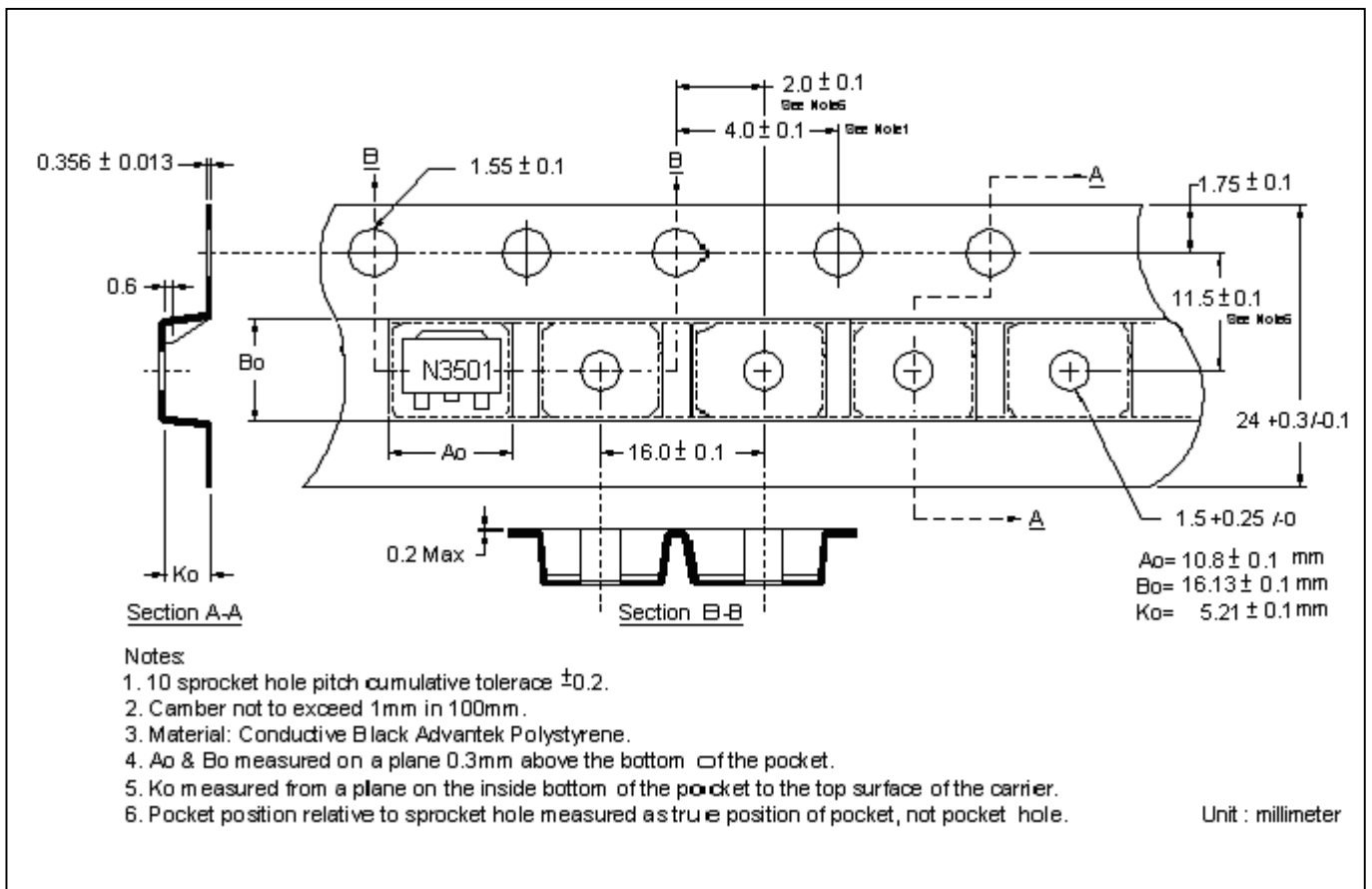

**TO-263 Dimension**

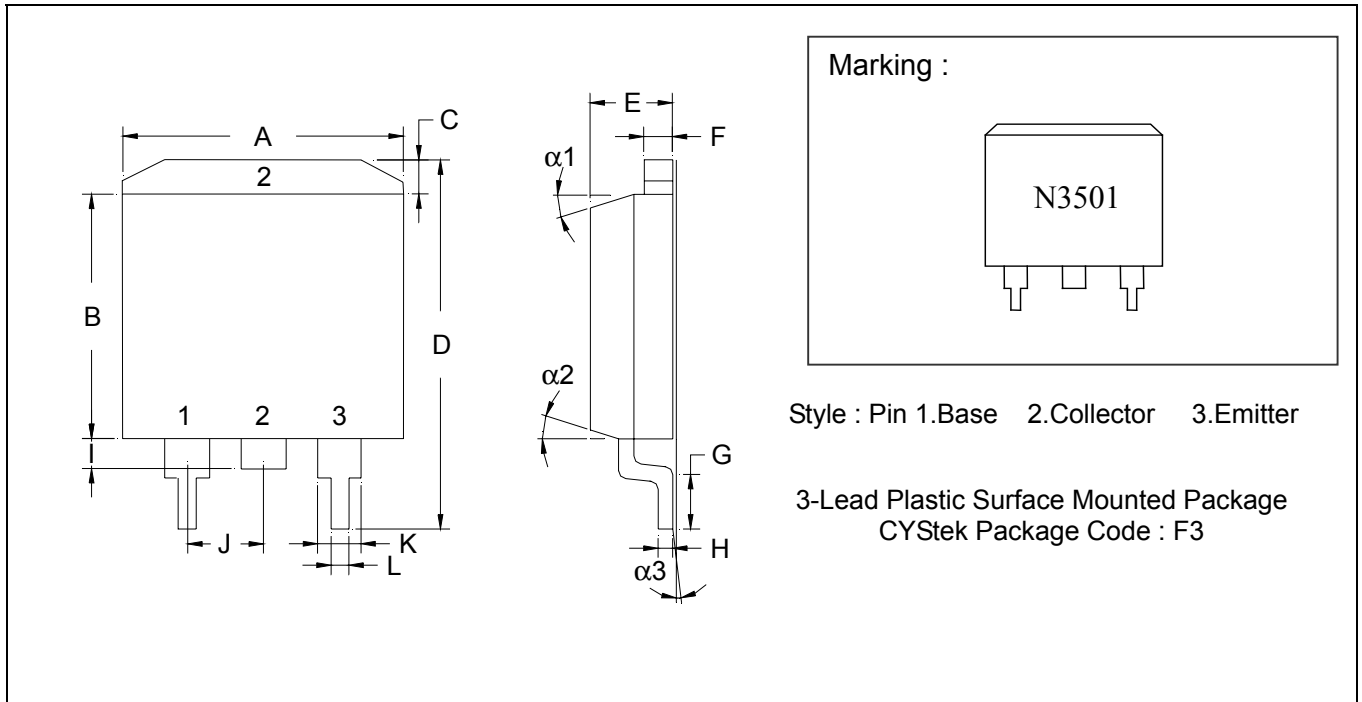

\*:Typical

DIM	Inches		Millimeters		DIM	Inches		Millimeters	
	Min.	Max.	Min.	Max.		Min.	Max.	Min.	Max.
A	0.3800	0.4050	9.65	10.29	I	0.0500	0.0700	1.27	1.78
B	0.3300	0.3700	8.38	9.40	J	-	*0.1000	-	*2.54
C	-	0.0550	-	1.40	K	0.0450	0.0550	1.14	1.40
D	0.5750	0.6250	14.61	15.88	L	0.0200	0.0390	0.51	0.99
E	0.1600	0.1900	4.06	4.83	$\alpha 1$	-	-	6°	8°
F	0.0450	0.0550	1.14	1.40	$\alpha 2$	-	-	6°	8°
G	0.0900	0.1100	2.29	2.79	$\alpha 3$	-	-	0°	5°
H	0.0180	0.0290	0.46	0.74					

Notes : 1.Controlling dimension : millimeters.  
 2.Maximum lead thickness includes lead finish thickness, and minimum lead thickness is the minimum thickness of base material.  
 3.If there is any question with packing specification or packing method, please contact your local CYStek sales office.

**Material :**

- Lead : 42 Alloy ; solder plating
- Mold Compound : Epoxy resin family, flammability solid burning class:UL94V-0

**Important Notice:**

- All rights are reserved. Reproduction in whole or in part is prohibited without the prior written approval of CYStek.
- CYStek reserves the right to make changes to its products without notice.
- CYStek **semiconductor products are not warranted to be suitable for use in Life-Support Applications, or systems.**
- CYStek assumes no liability for any consequence of customer product design, infringement of patents, or application assistance.