

Low Vcesat PNP Epitaxial Planar Transistor

BTPA92T3

Features

- High breakdown voltage, $BV_{CEO} \geq 300V$
- Excellent current gain characteristics
- Complementary to BTNA42T3
- Pb-free lead plating and halogen-free package

Symbol

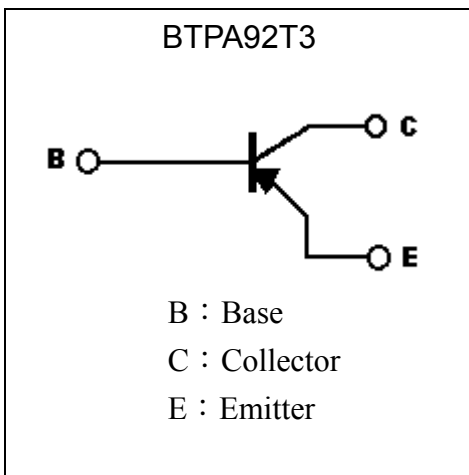

Outline

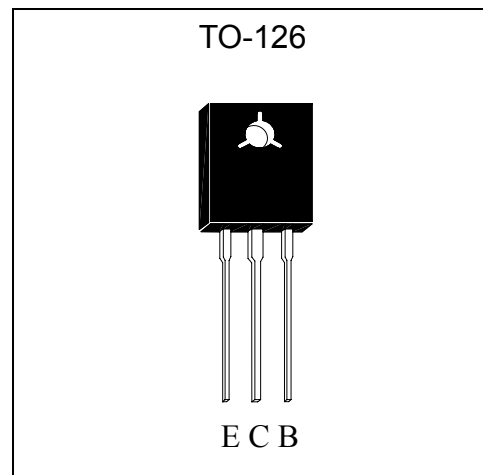

Ordering Information

Device	Package	Shipping
BTPA92T3-0-BL-X	TO-126 (Pb-free lead plating and halogen-free package)	200 pcs / bag, 3,000 pcs/box 30,000 pcs/carton

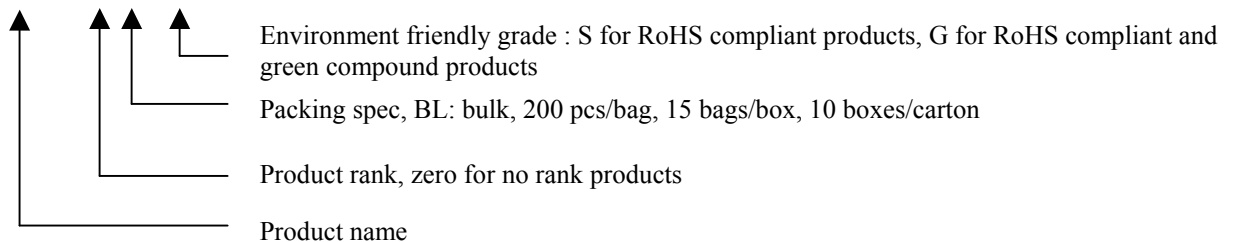



Absolute Maximum Ratings (Ta=25°C)

Parameter	Symbol	Limit	Unit
Collector-Base Voltage	V _{CBO}	-300	V
Collector-Emitter Voltage	V _{CEO}	-300	V
Emitter-Base Voltage	V _{EBO}	-7	V
Collector Current	I _C (DC)	-300	mA
	I _C (pulse)	-500 *1	mA
Power Dissipation	Pd(Ta=25°C)	1.2	W
	Pd(Tc=25°C)	10	
Operating Junction Temperature Range	T _j	-55~+150	°C
Storage Temperature Range	T _{stg}	-55~+150	°C

Note : *1. Single Pulse Pw≤300μs, Duty≤2%.

Characteristics (Ta=25°C)

Symbol	Min.	Typ.	Max.	Unit	Test Conditions
BV _{CBO}	-300	-	-	V	I _C =-100μA, I _E =0
BV _{CEO}	-300	-	-	V	I _C =-1mA, I _B =0
BV _{EBO}	-7	-	-	V	I _E =-100μA, I _C =0
I _{CBO}	-	-	-100	nA	V _{CB} =-300V
I _{EBO}	-	-	-100	nA	V _{EB} =-7V
*V _{CE(sat)}	-	-0.09	-0.2	V	I _C =-20mA, I _B =-2mA
*V _{CE(sat)}	-	-0.13	-0.3	V	I _C =-50mA, I _B =-5mA
*V _{CE(sat)}	-	-0.19	-0.5	V	I _C =-100mA, I _B =-10mA
*V _{BE(sat)}	-	-0.73	-1	V	I _C =-20mA, I _B =-2mA
*h _{FE1}	120	-	270	-	V _{CE} =-10V, I _C =-10mA
*h _{FE2}	60	-	-	-	V _{CE} =-10V, I _C =-100mA
f _T	-	73	-	MHz	V _{CE} =-20V, I _C =-50mA, f=100MHz
Cob	-	7.3	-	pF	V _{CB} =-10V, f=1MHz

*Pulse Test : Pulse Width ≤300μs, Duty Cycle≤2%



Typical Characteristics

Emitter Grounded Output Characteristics

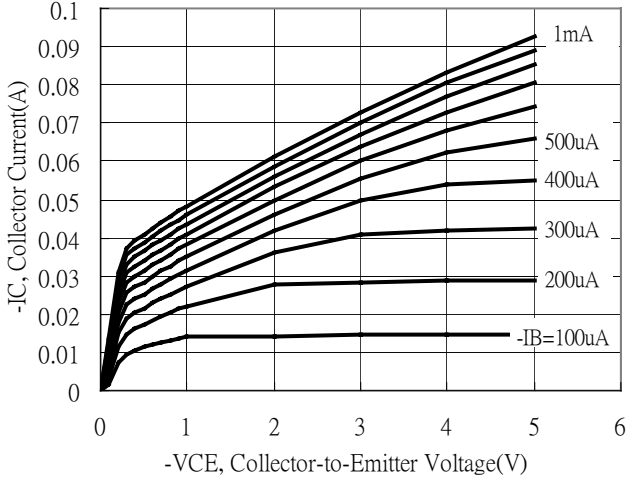

Emitter Grounded Output Characteristics

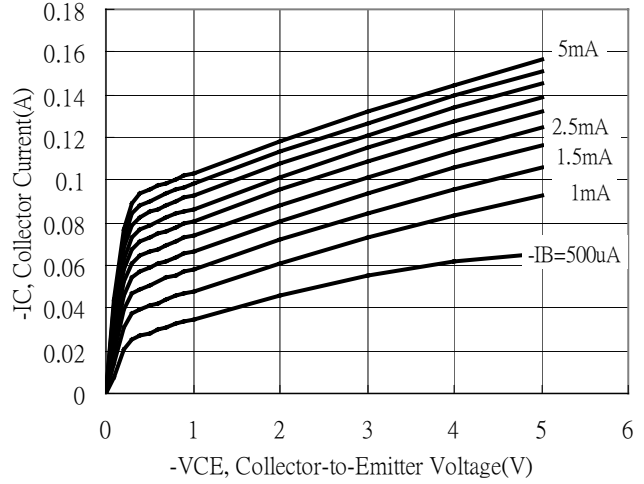

Emitter Grounded Output Characteristics

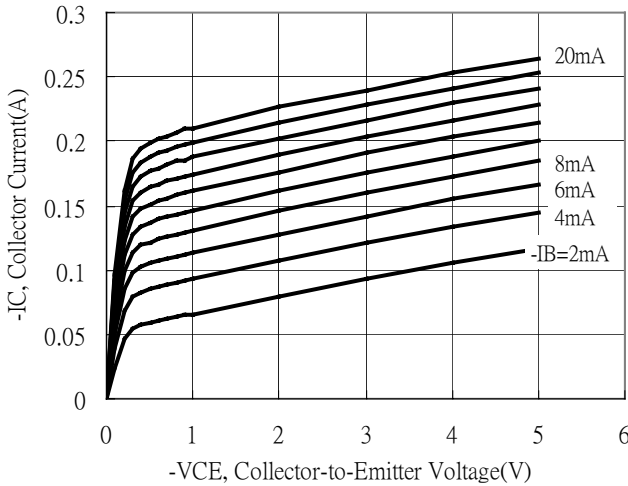

Emitter Grounded Output Characteristics

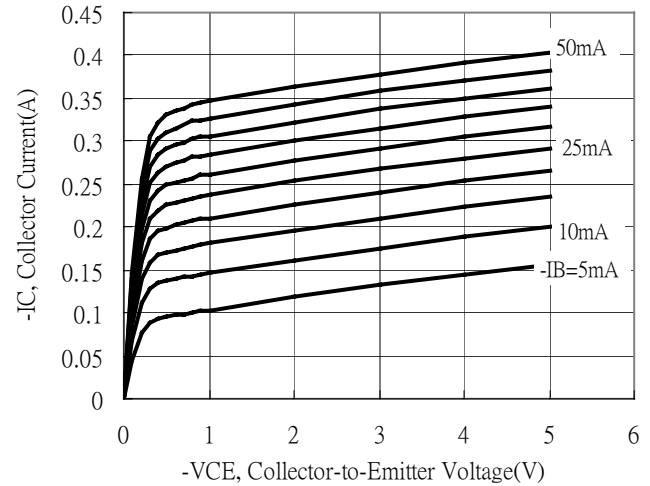

Current Gain vs Collector Current

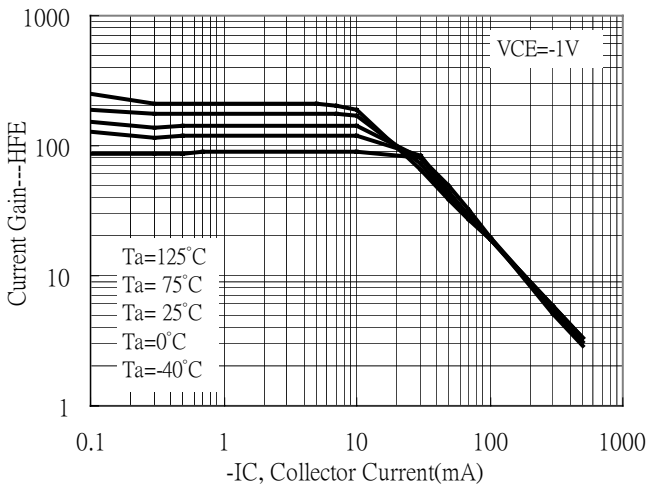

Current Gain vs Collector Current

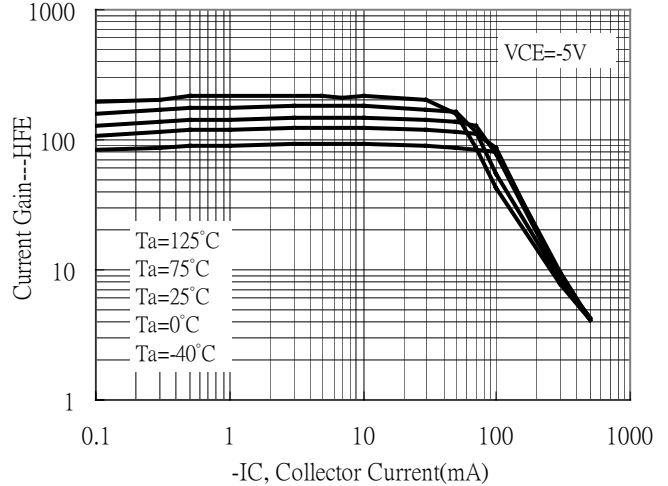



Typical Characteristics (Cont.)

Current Gain vs Collector Current

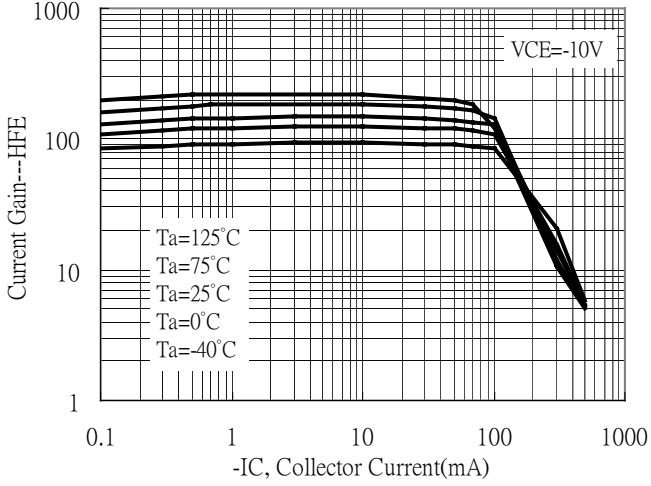

Saturation Voltage vs Collector Current

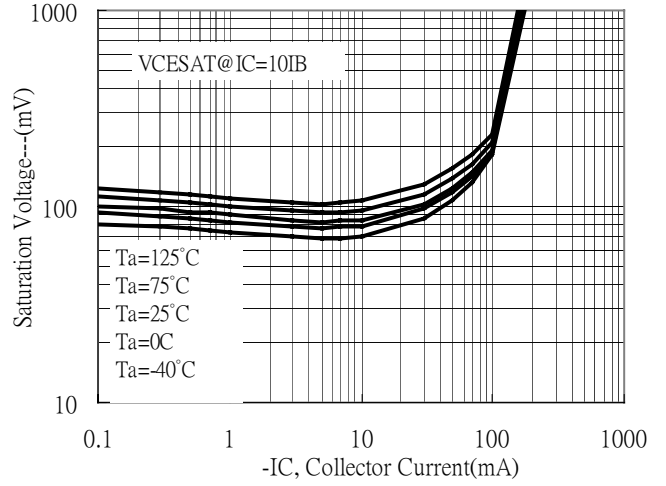

Saturation Voltage vs Collector Current

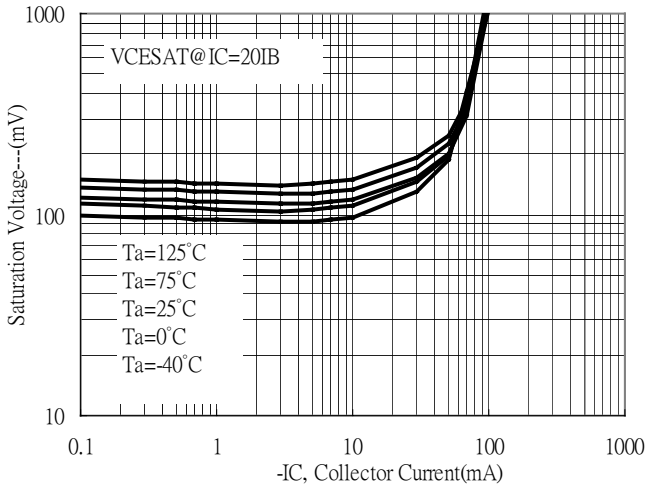

Saturation Voltage vs Collector Current

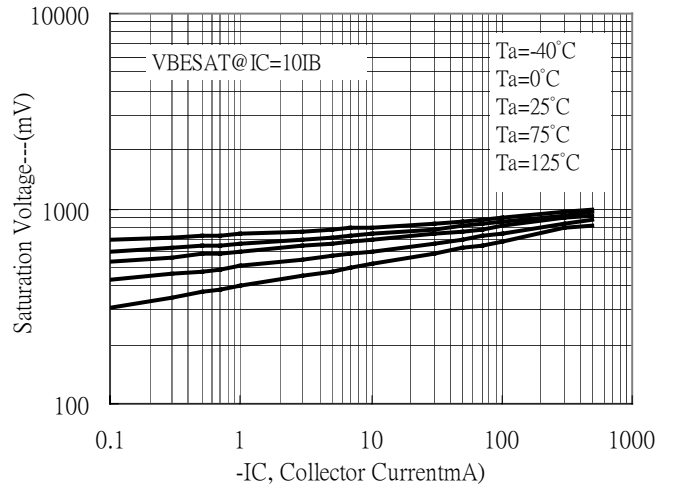

On Voltage vs Collector Current

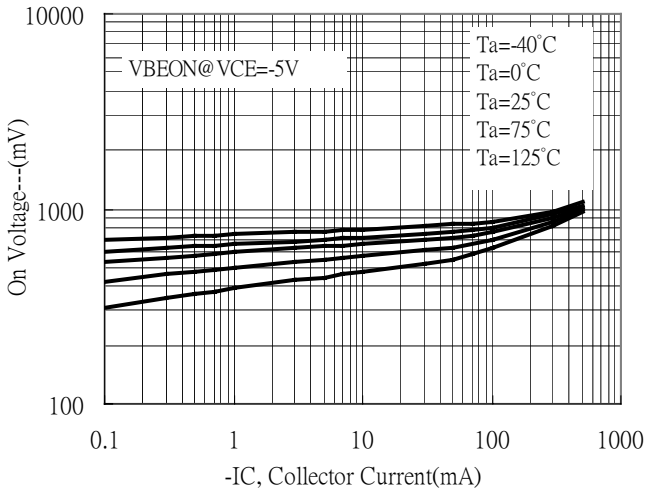

Capacitance vs Reverse-biased Voltage

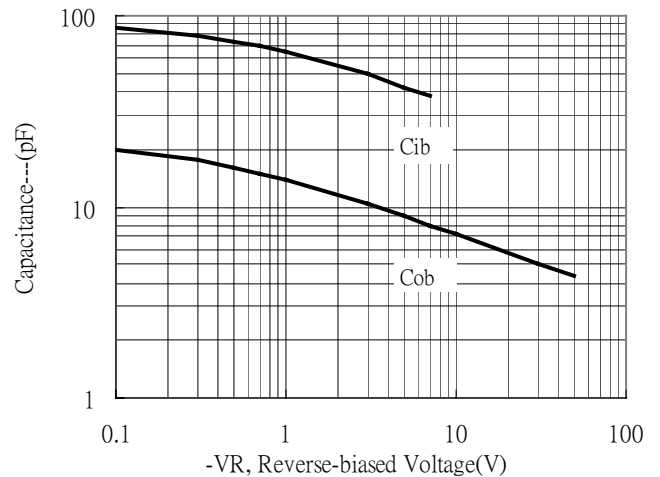



Typical Characteristics (Cont.)

Cutoff Frequency vs Collector Current

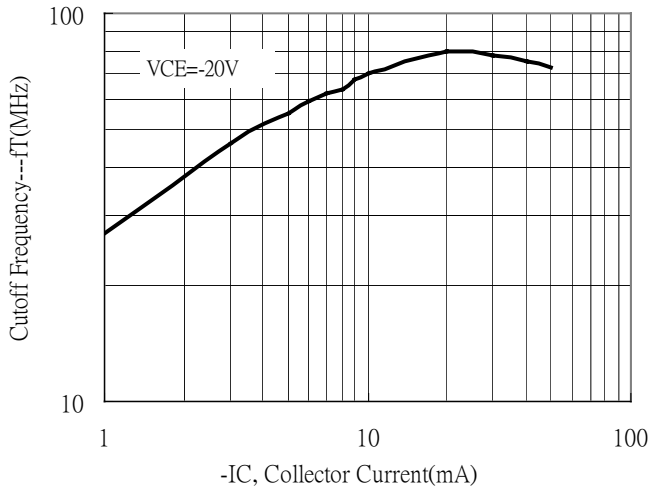

Power Derating Curve

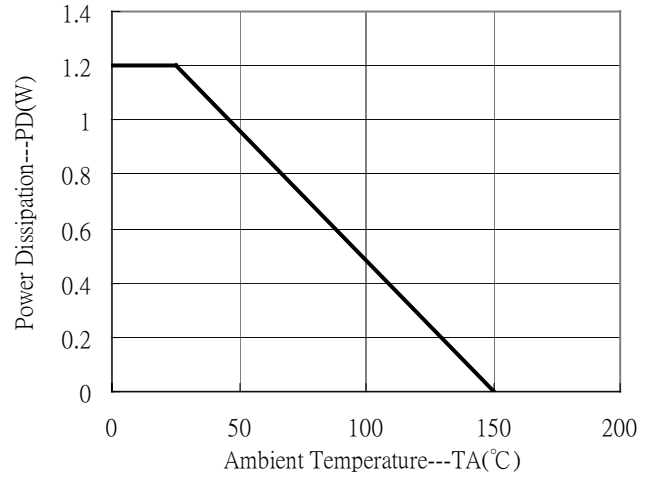

Power Derating Curve

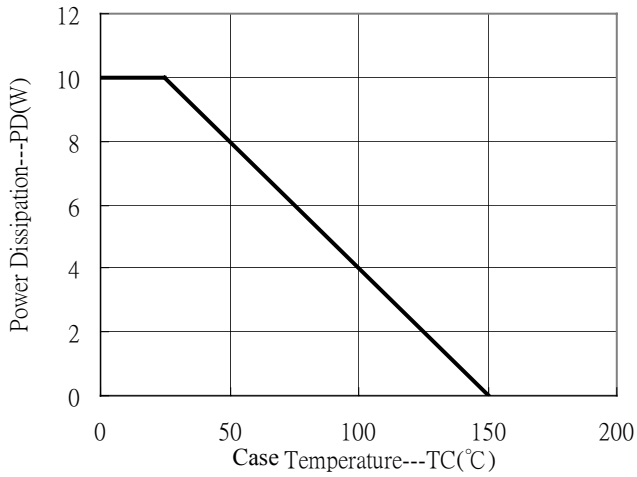

Recommended wave soldering condition

Product	Peak Temperature	Soldering Time
Pb-free devices	260 +0/-5 °C	5 +1/-1 seconds

Recommended temperature profile for IR reflow

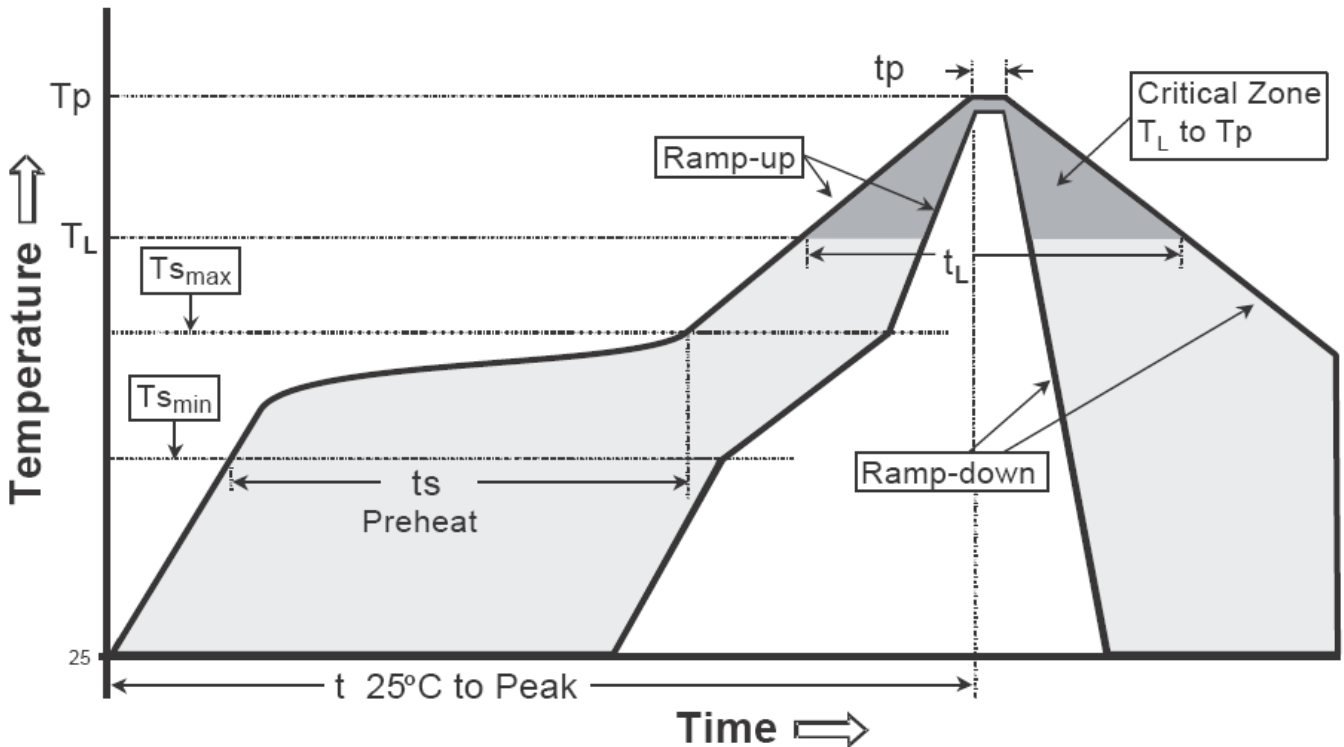

Profile feature	Sn-Pb eutectic Assembly	Pb-free Assembly
Average ramp-up rate (T _{smax} to T _p)	3°C/second max.	3°C/second max.
Preheat		
-Temperature Min(T _{s min})	100°C	150°C
-Temperature Max(T _{s max})	150°C	200°C
-Time(t _{s min} to t _{s max})	60-120 seconds	60-180 seconds
Time maintained above:		
-Temperature (T _L)	183°C	217°C
- Time (t _L)	60-150 seconds	60-150 seconds
Peak Temperature(T _P)	240 +0/-5 °C	260 +0/-5 °C
Time within 5°C of actual peak temperature(tp)	10-30 seconds	20-40 seconds
Ramp down rate	6°C/second max.	6°C/second max.
Time 25 °C to peak temperature	6 minutes max.	8 minutes max.

Note : All temperatures refer to topside of the package, measured on the package body surface.

TO-126 Dimension

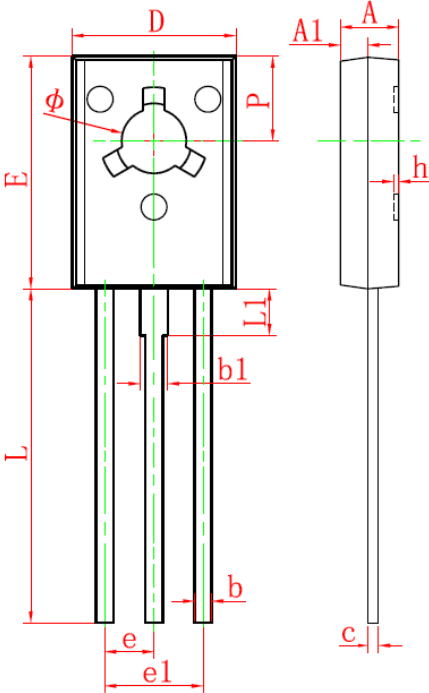

Style: Pin 1. Emitter 2. Collector 3. Base

3-Lead TO-126 Plastic Package
 CYStek Package Code: T3

Marking:

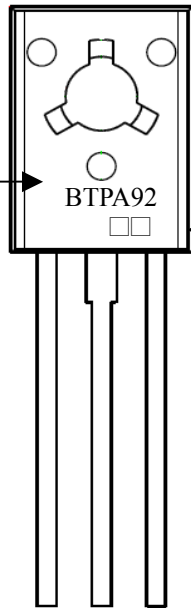

Device Name → BTPA92 ← Date Code

Date Code : Year Code + Month Code
 Year Code : 2011→1, 2012→2, ..., 2020→0,
 2021→1, 2022→2, ..., etc
 Month Code : Jan →1, Feb → 2, ..., Sep→9,
 Oct→A, Nov→B, Dec→C

*: Typical

DIM	Millimeters		Inches		DIM	Millimeters		Inches	
	Min.	Max.	Min.	Max.		Min.	Max.	Min.	Max.
A	2.500	2.900	0.098	0.114	e	*2.290		*0.090	
A1	1.100	1.500	0.043	0.059	e1	4.480	4.680	0.176	0.184
b	0.660	0.860	0.026	0.034	h	0.000	0.300	0.000	0.012
b1	1.170	1.370	0.046	0.054	L	15.300	15.700	0.602	0.618
c	0.450	0.600	0.018	0.024	L1	2.100	2.300	0.083	0.091
D	7.400	7.800	0.291	0.307	P	3.900	4.100	0.154	0.161
E	10.600	11.000	0.417	0.433	Φ	3.000	3.200	0.118	0.126

Notes: 1. Controlling dimension: millimeters.
 2. Maximum lead thickness includes lead finish thickness, and minimum lead thickness is the minimum thickness of base material.
 3. If there is any question with packing specification or packing method, please contact your local CYStek sales office.

Material:

- Lead: Pure tin plated.
- Mold Compound: Epoxy resin family, flammability solid burning class: UL94V-0.

Important Notice:

- All rights are reserved. Reproduction in whole or in part is prohibited without the prior written approval of CYStek.
- CYStek reserves the right to make changes to its products without notice.
- CYStek **semiconductor products are not warranted to be suitable for use in Life-Support Applications, or systems.**
- CYStek assumes no liability for any consequence of customer product design, infringement of patents, or application assistance.