

Silicon NPN Power Transistors

BU2508A

DESCRIPTION

www.datasheet4u.com

- With TO-3PN package
- High voltage
- High speed switching

APPLICATIONS

- For use in horizontal deflection circuits of colour TV receivers.

PINNING

PIN	DESCRIPTION
1	Base
2	Collector;connected to mounting base
3	Emitter

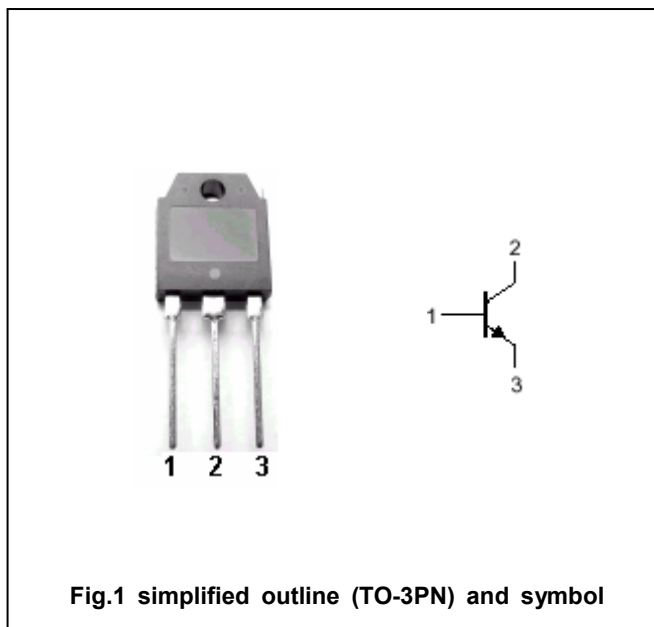

Fig.1 simplified outline (TO-3PN) and symbol

Absolute maximum ratings (Ta=25°C)

SYMBOL	PARAMETER	CONDITIONS	VALUE	UNIT
V <sub>CBO</sub>	Collector-base voltage	Open emitter	1500	V
V <sub>CEO</sub>	Collector-emitter voltage	Open base	700	V
V <sub>EBO</sub>	Emitter-base voltage	Open collector	7.5	V
I <sub>C</sub>	Collector current		8	A
I <sub>CM</sub>	Collector current -peak		15	A
I <sub>B</sub>	Base current		4	A
I <sub>BM</sub>	Base current-peak		6	A
P <sub>C</sub>	Collector power dissipation	T <sub>C</sub> =25°C	125	W
T <sub>j</sub>	Junction temperature		150	°C
T <sub>stg</sub>	Storage temperature		-65~150	°C

## Silicon NPN Power Transistors

## BU2508A

## CHARACTERISTICS

www.datasheet4u.com

 $T_j=25^\circ\text{C}$  unless otherwise specified

SYMBOL	PARAMETER	CONDITIONS	MIN	TYP.	MAX	UNIT
$V_{CEO(SUS)}$	Collector-emitter sustaining voltage	$I_C=0.1\text{A}; I_B=0; L=25\text{mH}$	700			V
$V_{(BR)EBO}$	Emitter-base breakdown voltage	$I_E=1\text{mA}; I_C=0$	7.5	13.5		V
$V_{CEsat-1}$	Collector-emitter saturation voltage	$I_C=4.5\text{A}; I_B=1.1\text{A}$			5.0	V
$V_{CEsat-2}$	Collector-emitter saturation voltage	$I_C=4.5\text{A}; I_B=1.29\text{A}$			1.0	V
$V_{BEsat}$	Base-emitter saturation voltage	$I_C=4.5\text{A}; I_B=1.7\text{A}$			1.3	V
$I_{CES}$	Collector cut-off current	$V_{CE}=\text{rated}; V_{BE}=0$ $T_j=125^\circ\text{C}$			1.0 2.0	mA
$I_{EBO}$	Emitter cut-off current	$V_{EB}=7.5\text{V}; I_C=0$			1.0	mA
$h_{FE-1}$	DC current gain	$I_C=0.1\text{A}; V_{CE}=5\text{V}$	6	13	26	
$h_{FE-2}$	DC current gain	$I_C=4.5\text{A}; V_{CE}=1\text{V}$	4	5.5	7.5	
$C_C$	Collector capacitance	$V_{CB}=10\text{V}; f=1\text{MHz}$		80		pF

PACKAGE OUTLINE

www.datasheet4u.com

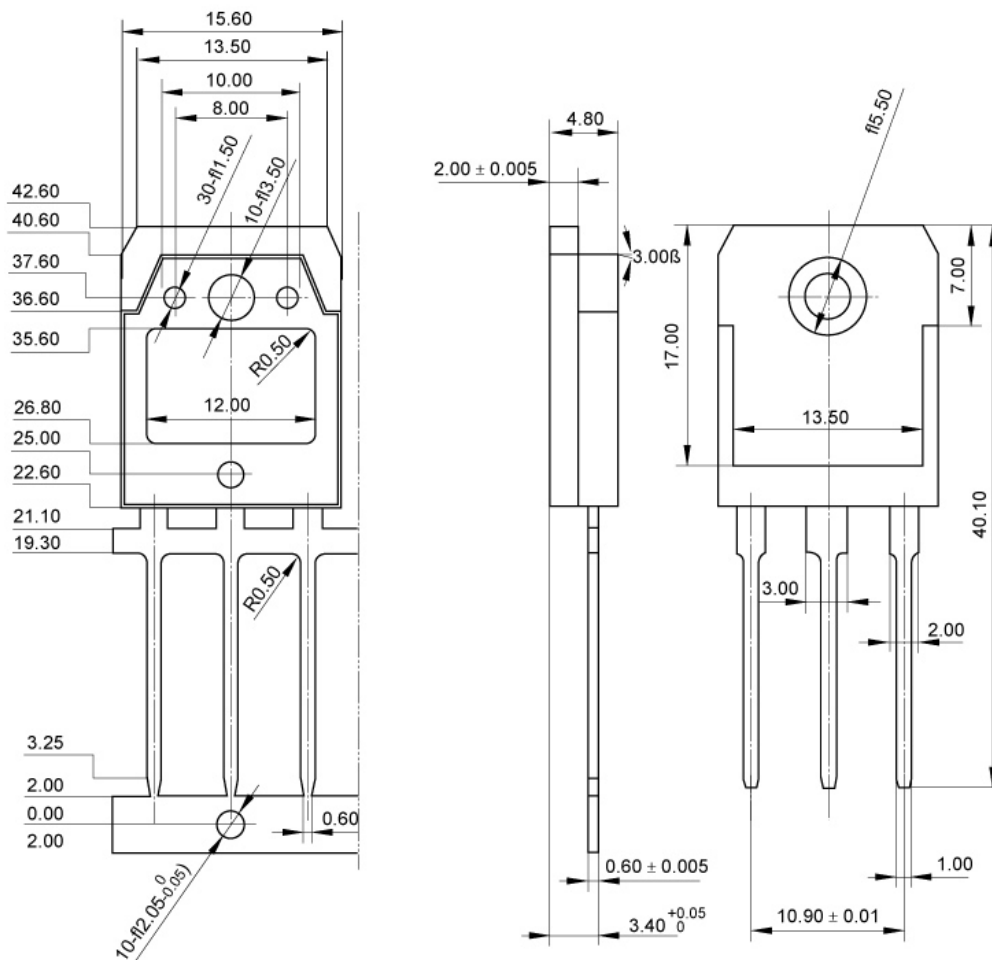

Fig.2 outline dimensions (unindicated tolerance:±0.10 mm)