

Silicon NPN Power Transistors

BU2727AW

DESCRIPTION

www.datasheet4u.com

- With TO-247 package
- High voltage
- High speed switching

APPLICATIONS

- For use in horizontal deflection circuits of high resolution monitors

PINNING

PIN	DESCRIPTION
1	Base
2	Collector
3	Emitter

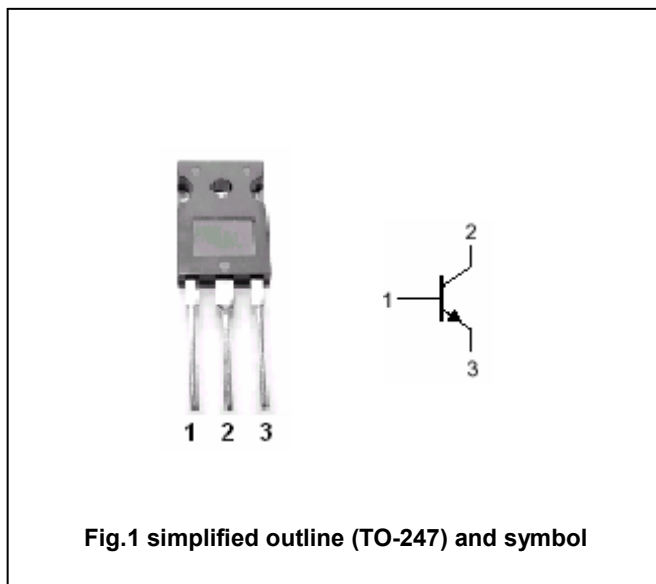

Fig.1 simplified outline (TO-247) and symbol

Absolute maximum ratings(Ta=25°C)

SYMBOL	PARAMETER	CONDITIONS	VALUE	UNIT
V <sub>CBO</sub>	Collector-base voltage	Open emitter	1700	V
V <sub>CEO</sub>	Collector-emitter voltage	Open base	825	V
V <sub>EBO</sub>	Emitter-base voltage	Open collector	7.5	V
I <sub>C</sub>	Collector current (DC)		12	A
I <sub>CM</sub>	Collector current -peak		30	A
I <sub>B</sub>	Base current (DC)		12	A
I <sub>BM</sub>	Base current -peak		25	A
P <sub>tot</sub>	Total power dissipation	T <sub>C</sub> =25°C	125	W
T <sub>j</sub>	Junction temperature		150	°C
T <sub>stg</sub>	Storage temperature		-65~150	°C

## Silicon NPN Power Transistors

## BU2727AW

## CHARACTERISTICS

T<sub>j</sub>=25°C unless otherwise specified

www.datasheet4u.com

SYMBOL	PARAMETER	CONDITIONS	MIN	TYP.	MAX	UNIT
V <sub>CEO(SUS)</sub>	Collector-emitter sustaining voltage	I <sub>C</sub> =100mA ; I <sub>B</sub> =0, L=25mH	825			V
V <sub>(BR)EBO</sub>	Emitter-base breakdown voltage	I <sub>E</sub> =1mA ; I <sub>C</sub> =0	7.5	13.5		V
V <sub>CEsat</sub>	Collector-emitter saturation voltage	I <sub>C</sub> =5A ; I <sub>B</sub> =0.91A			1.0	V
V <sub>BEsat</sub>	Base-emitter saturation voltage	I <sub>C</sub> =5A ; I <sub>B</sub> =0.91A			0.95	V
I <sub>CES</sub>	Collector cut-off current	V <sub>CE</sub> =BV <sub>CES</sub> ; V <sub>BE</sub> =0 T <sub>j</sub> =125°C			1.0 2.0	mA
I <sub>EBO</sub>	Emitter cut-off current	V <sub>EB</sub> =7.5V; I <sub>C</sub> =0			1.0	mA
h <sub>FE-1</sub>	DC current gain	I <sub>C</sub> =0.1A ; V <sub>CE</sub> =5V		22		
h <sub>FE-2</sub>	DC current gain	I <sub>C</sub> =5A ; V <sub>CE</sub> =1V	5.5	8	11	

Silicon NPN Power Transistors

BU2727AW

PACKAGE OUTLINE

www.datasheet4u.com

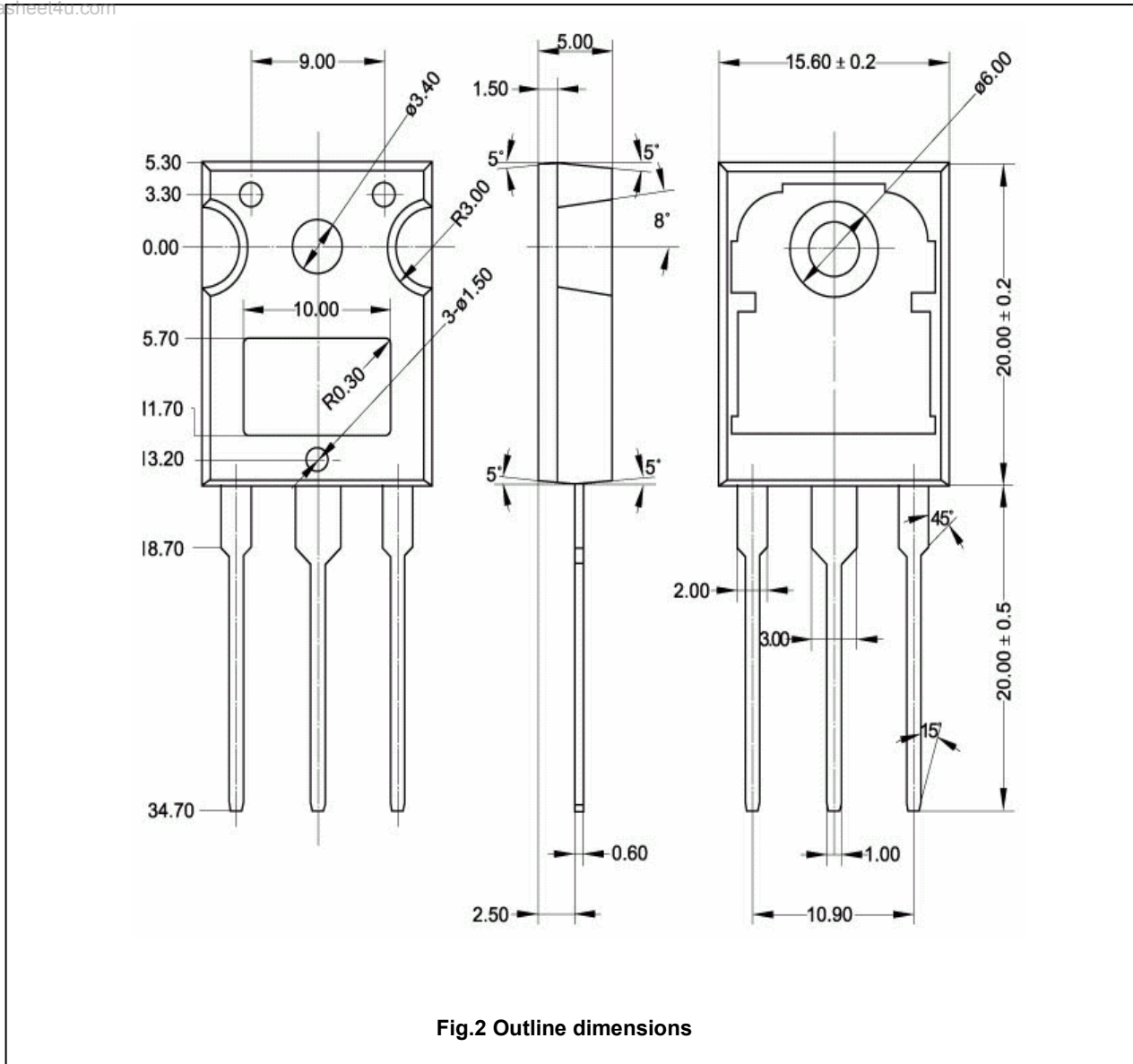

Fig.2 Outline dimensions