

CMOS Camera BU Series

BU205M

BU406M

BU406MC/BU406MCF

Specifications

TOSHIBA TELI CORPORATION

Information contained in this document is subject to change without prior notice.

Contents

RESTRICTION FOR USE	1
CASES FOR INDEMNITY (LIMITED WARRANTY)	2
USAGE PRECAUTIONS	3
1. Overview	5
2. Features	5
3. Configuration	6
4. Optional part	6
5. Functions	7
6. Specifications	15
7. Timing chart	25
8. Warranty rules	27
9. Repair	28
10. Outline Drawing	29

RESTRICTION FOR USE

- Should the equipment be used in the following conditions or environments, give consideration to safety measures and inform us of such usage:
 - (1) Use of the equipment in the conditions or environment contrary to those specified, or use outdoors.
 - (2) Use of the equipment in applications expected to cause potential hazard to people or property, which require special safety measures to be adopted.
- This product can be used under diverse operating conditions. Determination of applicability of equipment or devices concerned shall be determined after analysis or testing as necessary by the designer of such equipment or devices, or personnel related to the specifications. Such designer or personnel shall assure the performance and safety of the equipment or devices.
- This product is not designed or manufactured to be used for control of equipment directly concerned with human life (*1) or equipment relating to maintenance of public services/functions involving factors of safety (*2). Therefore, the product shall not be used for such applications.
 - (*1): Equipment directly concerned with human life refers to.
 - Medical equipment such as life-support systems, equipment for operating theaters.
 - Exhaust control equipment for exhaust gases such as toxic fumes or smoke.
 - Equipment mandatory to be installed by various laws and regulations such as the Fire Act or Building Standard Law
 - Equipment related to the above
 - (*2) :Equipment relating to maintenance of public services/functions involving factors of safety refers to.
 - Traffic control systems for air transportation, railways, roads, or marine transportation
 - Equipment for nuclear power generation
 - Equipment related to the above

CASES FOR INDEMNITY (LIMITED WARRANTY)

We shall be exempted from taking responsibility and held harmless for damage or losses incurred by the user in the following cases.

- Natural disasters, such as an earthquake and thunder, fire or any other act of God; acts by third parties; misuse by the user, whether intentional or accidental; use under extreme operating conditions.
- In the case of indirect, additional, consequential damages (loss of business interests, suspension of business activities) are incurred as result of malfunction or non-function of the equipment, we shall be exempted from responsibility for such damages.
- In the case damage or losses are caused by failure to observe the information contained in the instructions in this instruction manual and specifications.
- In the case damage or losses are caused by use contrary to the instructions in this instruction manual and specifications.
- In the case damage or losses are caused by malfunction or other problems resulting from use of equipment or software that is not specified.
- In the case damage or losses are caused by repair or modification conducted by the customer or any unauthorized third party (such as an unauthorized service representative).
- Expenses we bear on this product shall be limited to the individual price of the product.
- The item that is not described in specifications of this product is off the subject of the guarantee.
- The attachment mistake of a cable.

USAGE PRECAUTIONS

● Handle carefully

Do not drop the equipment or allow it to be subject to strong impact or vibration, as such action may cause malfunctions. Further, do not damage the connection cable, since this may cause wire breakage.

● Environmental operating conditions

Do not use the product in locations where the ambient temperature or humidity exceeds the specifications.

Otherwise, image quality may be degraded or internal components may be adversely affected. In particular, do not use the product in areas exposed to direct sunlight.

● Combination of C-mount lens

Depending on the lens you use, the performance of the camera may not be brought out fully due to the deterioration in resolution and brightness in the peripheral area, occurrence of a ghost, aberration and others. When you check the combination between the lens and camera, be sure to use the lens you actually use.

When installing a lens in the camera, make sure carefully that it is not tilted.

In addition, use a mounting screw free from defects and dirt. Otherwise, the camera may be unable to be removed.

As for the C-mount lens used combining this product, the projection distance from bottom of the screw should use 10mm or less.

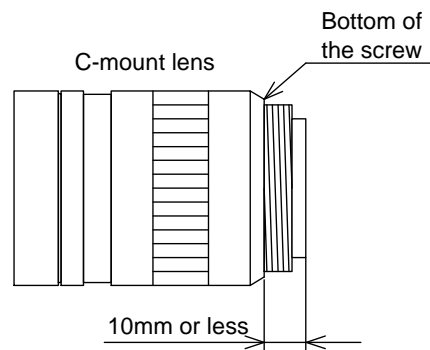

● Mounting to a pedestal

When mounting this product to a pedestal, make sure carefully that the lens doesn't touch with the pedestal.

● Do not expose the camera's image-pickup-plane to sunlight or other intense light directly.

Its inner CMOS sensor might be damaged.

● Occurrence of moiré

If you shoot thin stripe patterns, moiré patterns (interference fringes) may appear. This is not a malfunction.

● Occurrence of noise on the screen

If an intense magnetic or electromagnetic field is generated near the camera or connection cable, noise may be generated on the screen. If this occurs, move the camera or the cable.

USAGE PRECAUTIONS

- **Handling of the protective cap**

If the camera is not in use, attach the lens cap to the camera to protect the image pickup surface.

- **If the equipment is not to be used for a long duration**

Turn off power to the camera for safety.

- **Maintenance**

Turn off power to the equipment and wipe it with a dry cloth.

If it becomes severely contaminated, gently wipe the affected areas with a soft cloth dampened with diluted neutral detergent. Never use alcohol, benzene, thinner, or other chemicals because such chemicals may damage or discolor the paint and indications.

If the image pickup surface becomes dusty, contaminated, or scratched, consult your sales representative.

- **Disposal**

When disposing of the camera, it may be necessary to disassemble it into separate parts, in accordance with the laws and regulations of your country and/or municipality concerning environmental contamination.

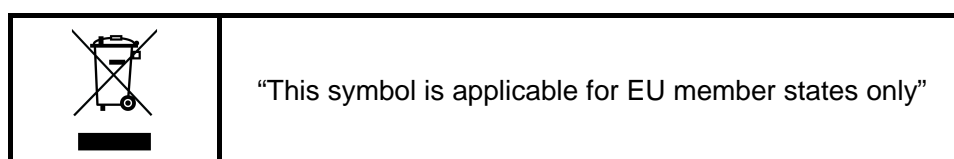

[Phenomena specific to CMOS sensor]

- **Defective pixels**

A CMOS image sensor is composed of photo sensor pixels in a square grid array. Due to the characteristics of CMOS image sensors, over- or under-driving of the pixels results in temporary white or black areas (as if these are noises) appearing on the screen. This phenomenon, which is not a defect is exacerbated under higher temperatures and long exposure time.

- **Image shading**

The brightness of the upper part of the screen may be different from that of the lower part. Note that this is a characteristic of a CMOS image sensor and is not a fault.

1. Overview

This BU CMOS series is an integrated-(one-body)-type camera that adopts a global shutter CMOS sensor. These are BU205M (2M 2/3 type) BU406M (4M 1/1 type). Suffix [C] or [CF] are attached to the color models. For video output and camera control, the USB 3.0 interface standard is adopted for high transfer rate, and it is easy to integrate into industrial equipment.

2. Features

2.1 High frame rate

Supporting high frame rate, BU205M 170fps, BU406M/C 90fps.

2.2 Global shutter

As it employs a global electronic shutter similar to a CCD image sensor, clear images of even fast-moving object are obtainable with less blur.

2.3 USB* 3.0 interface

Video output and camera control are performed via the USB 3.0 standard interface. Data transfer is up to 5Gbps (Maximum) that enables to output uncompressed video data at high frame rate.

2.4 USB3 Vision*

This product is based on USB3 Vision Ver.1.0.

2.5 GenICam* Ver.2.3

This product is based on GenICam Generic Interface for Cameras Ver.2.3.

2.6 IIDC2* Digital Camera Control Specification Ver.1.0.0

This product is based on IIDC2 Digital Camera Control Specification Ver.1.0.0.

2.7 e-CON* Connector adoption

The e-CON connector adoption enables to assemble the cable easily without using special tools.

2.8 Random Trigger Shutter

The Random Trigger Shutter function provides images in any timing by input of an external trigger signal. Trigger control from PC is available as well.

2.9 Scalable

Selectable video output area. This mode achieves higher frame rate by reducing vertical output area. And reduces occupied data rate of USB bus by reducing horizontal output area.

2.10 Decimation

Camera reads all effective areas at high speed by skipping lines.

2.11 Color processing

Color models have built in color processing. Color processing features like white balance are available in Bayer output mode.

2.12 IR-cut filter

Build-in IR-cut filter models are optional for color models.

Suffix [F] is attached to the model name of built-in IR-cut filter model. (e.g. BU406MCF)

* Suffix [F] is not shown in the common part of specifications.

2.13 Compact and lightweight

This camera is compact and lightweight; it is easy to integrate into industrial equipment.

2.14 EU RoHS & Chinese ROHS

* USB is a unified standard established by USB-IF(USB Implementers Forum).

* USB3 Vision is a unified standard established by AIA (Automated Imaging Association).

* GenICam is a registered trademark of EMVA (European Machine Vision Association).

* IIDC2 is a unified standard established by JIIA (Japan Industrial Association).

* e-CON (Easy & Economy connector) is a sensor connector that is normalized by the manufacturer of the sensor, FA equipment and connector.

3. Configuration

(1) Camera body

* No application software and manuals are attached to this camera.

4. Optional part

- Camera mounting kit Model name: CPTBU

* Contact your dealer / distributor for details of option units.

5. Functions

5.1 Gain

Manual gain control is available up to 8 times.

Notes on gain setting:

Setting the gain value too high increases noises. When you adjust the brightness of the image, I ask you to have final image quality checked with your environment.

5.2 Black Level

Black level is adjustable from -25% to +25% as white saturation level is 100%.

5.3 Gamma

Gamma correction curve is adjustable from 0.45 to 1.

5.4 LUT (Look up Table)

Arbitrary curve and binarization are possible by using 10 bit input and 10 bit output LUT.

5.5 Exposure Time

Manual exposure time control is available. Exposure time is adjustable by the internal sync signal.

5.6 White balance

Color models have two white balance modes, manual white balance (MWB) and one-push auto white balance (OPWB). Select the mode to suit the subject and purpose.

5.6.1 MWB

R/B gain can be set independently.

5.6.2 OPWB

When OPWB is executed, the camera adjusts R/B gain automatically.

5.7 Random Trigger Shutter

An image is captured at the desired timing using trigger signal input. External trigger signal from trigger input connector and software trigger from control command via the USB 3.0 interface are available (Edge mode / Bulk mode). Trigger polarity is selectable (High active / Low active).

Note that Random Trigger Shutter will cause a delay between trigger signal and start of exposure. See 7. Timing Chart for detail.

- Edge mode (TriggerSequence0)

The exposure time is determined by Exposure Time setting.

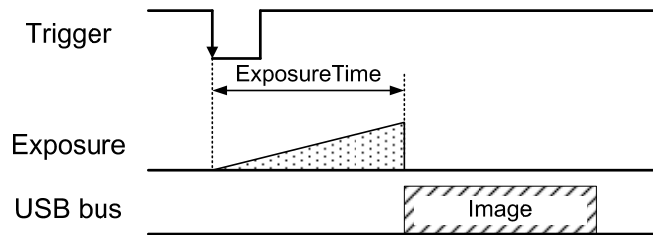

- Level mode (TriggerSequence1)

The exposure time is determined by the pulse width of the trigger signal.

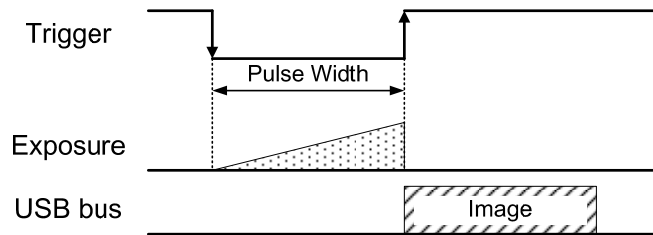

- Bulk mode (TriggerSequence6)

Camera exposes and transfers multiple frames by a single trigger.

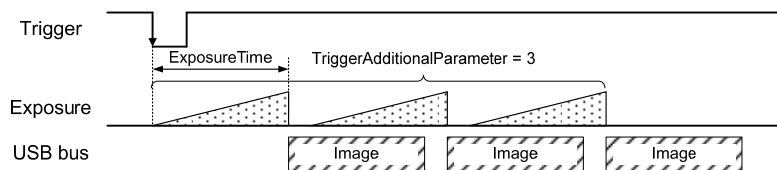

Notes on Random Trigger Shutter mode:

- In the period when FRAME_TRIGGER_WAIT signal is inactive, user must not input external trigger signal to this camera.
- When the interval of the input trigger signal is extremely short, or when the trigger signal is noisy, there is a possibility of causing the malfunction. In this case, please input a proper trigger signal.

5.8 Sequential Shutter

Sequential Shutter function performs sequential capturing with applying the settings of UserSet that have been made entry in advance.

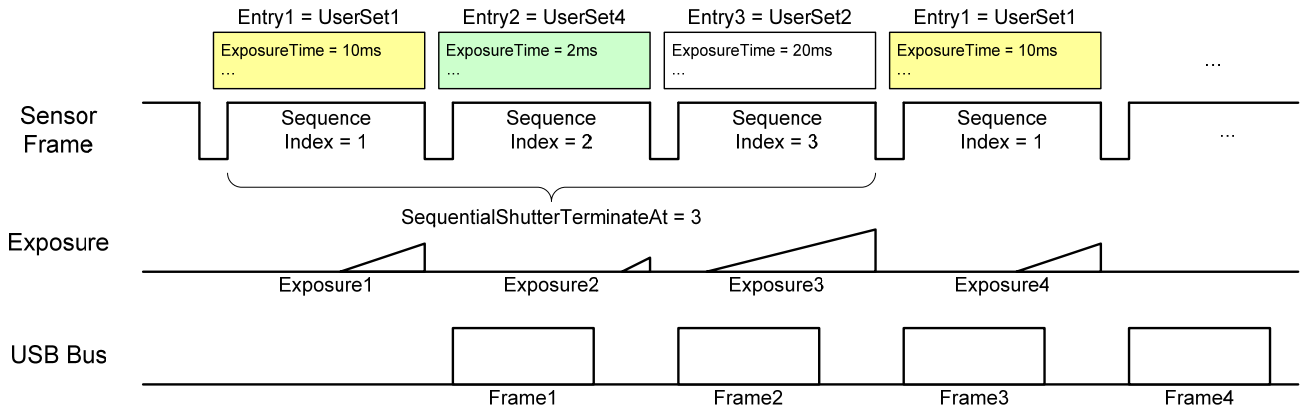

Note on Sequential Shutter:
 - In Sequential Shutter mode, window size is unchangeable.

5.9 Trigger Delay

You can add the delay between trigger signal input and the start of exposure.

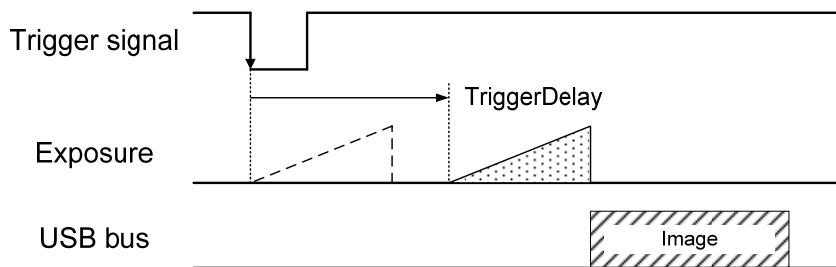

5.10 AntiGlitch – AntiChattering

AntiGlitch and AntiChattering functions filter noise and unstable state of the digital input (trigger signal).

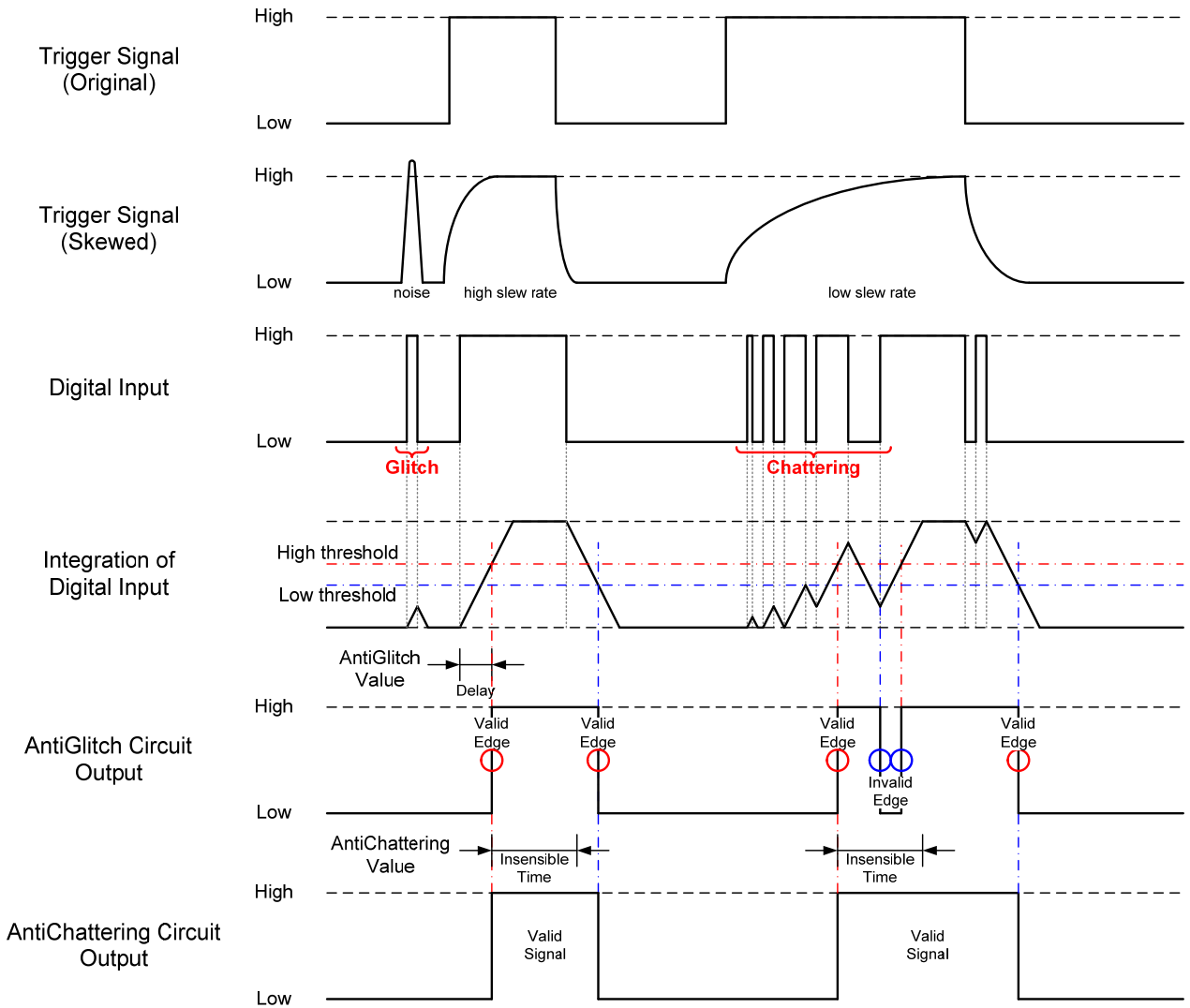

5.11 Event

Camera notifies FrameTrigger status and other information by USB3 Vision Event Packet.

- FrameTrigger : Reception of Frame Start Trigger
- FrameTriggerError : Rejection of Frame Start Trigger
- FrameTriggerWait : Start of waiting for Frame Start Trigger
- FrameTransferStart : Start of transferring streaming data
- FrameTransferEnd : End of transferring streaming data
- ExposureStart : Start of Exposure
- ExposureEnd : End of Exposure
- Timer0Start : Start of Timer0
- Timer0End : End of Timer0

Events timing are as following chart.

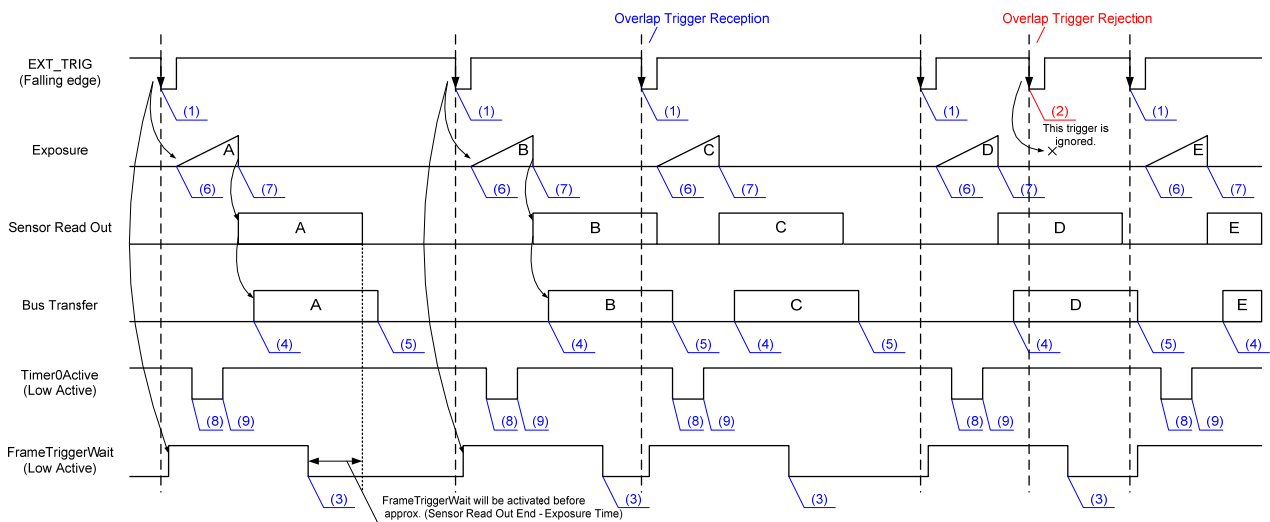

Event Name

- (1) FrameTrigger : Reception of Frame Start Trigger.
- (2) FrameTriggerError : Rejection of Frame Start Trigger.
- (3) FrameTriggerWait : Start of waiting for Frame Start Trigger.
- (4) FrameTransferStart : Start of transferring streaming data.
- (5) FrameTransferEnd : End of transferring streaming data.
- (6) ExposureStart : Start of Exposure.
- (7) ExposureEnd : End of Exposure.
- (8) Timer0Start : Start of Timer0.
- (9) Timer0End : End of Timer0.

5.12 GPIO

Selected signals are output from GPIO pins of I/O connector. Following signals are selectable.
Output signal is 5V CMOS.

- TIMER0 ACTIVE : This signal can be used as strobe control signal.
The delay time and pulse width of this signal are configurable.
- USER OUTPUT : Level selectable user output by register setting.
- EXPOSURE ACTIVE : Period from exposure start to end.
- FRAME ACTIVE : Period from exposure start to the CMOS transfer completion.
- FRAME TRANSFER : Period of transferring image data on USB bus.
- FRAME TRIGGER WAIT : Indicating waiting a Random Trigger Shutter.
An External trigger is input during this period,
exposure starts immediately.

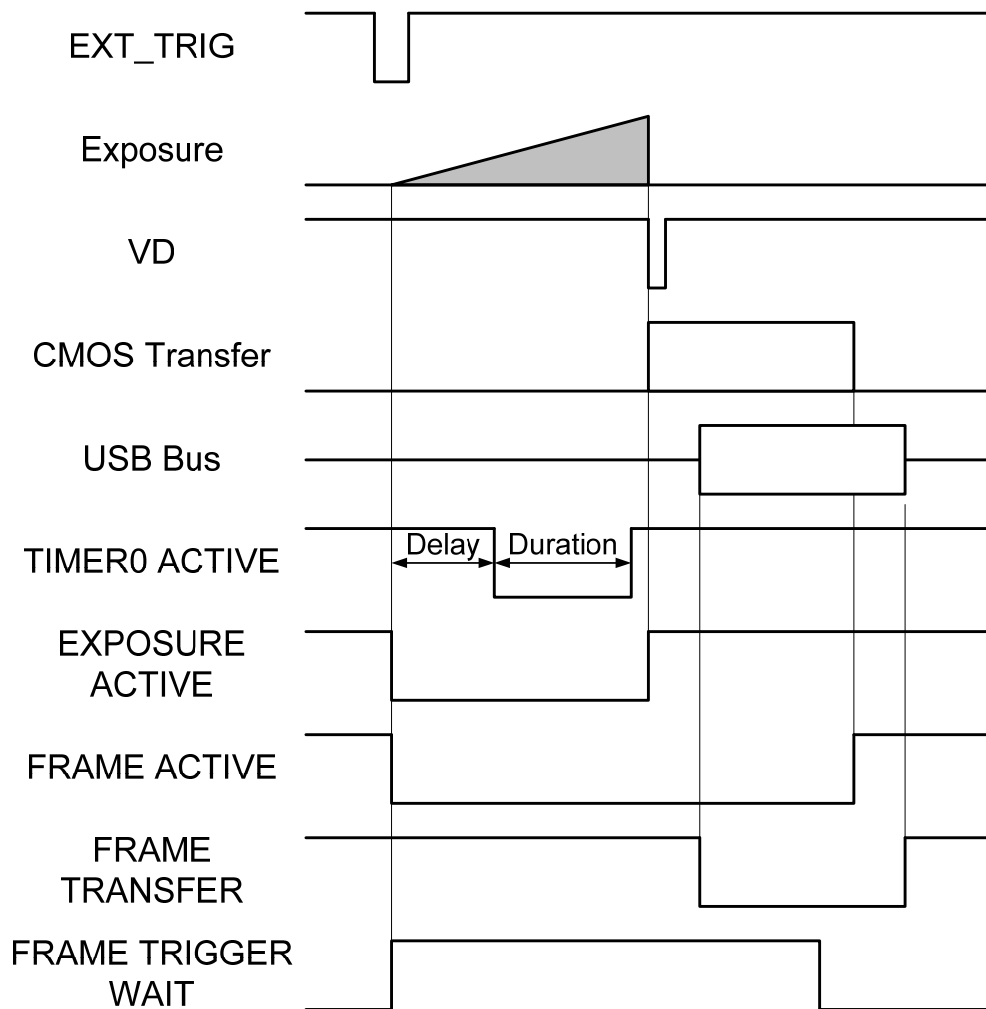

* ActiveLow

5.13 Scalable mode

Scalable mode is to read out arbitrary area of the image. Only single rectangle is selectable. Concave or convex shape is impossible. The number of selectable window is only one.

- Window size: $\{A+4*m (H)\} * \{B+2*n (V)\}$

A, B = minimum unit size

m, n = integer

The window size is equal or less than maximum image size.

- Start address: $\{4*i (H)\} * \{2*j (V)\}$

i, j = integer

The window size is equal or less than maximum image size.

Model Name	BU205M	BU406M/C
Width and OffsetX unit size	4	4
Height and OffsetY unit size	2	2
Minimum unit size (H) * (V)	64 x 8	64 x 64
Maximum unit size (H) * (V)	2048 x 1088	2048 x 2048

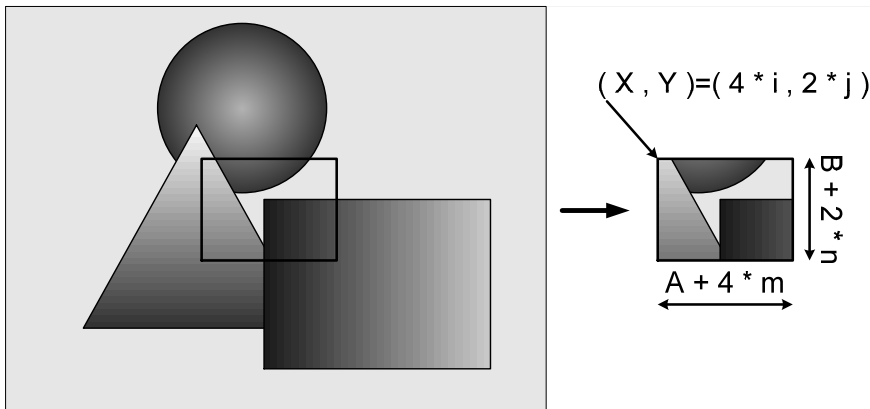

In the scalable mode, camera reads out only necessary area at the normal speed and reads out other area at high speed. The trigger interval can be shorter when the vertical height size is small.

5.14 Decimation

Camera reads all effective areas at high speed by skipping lines.

Model Name	BU205M	BU406M	BU406MC
Decimation Horizontal	1,2,4,8 line	1,2,4,8 line	-
Decimation Vertical	1,2,4,8 line	1,2,4,8 line	1,2,4,8 line

5.15 Reverse

Image can be flipped in horizontal and/or vertical direction.

5.16 Defect Pixel Correction

Defect Pixel Correction is available up to 256 pixels.

5.17 FPN Correction

FPN (Fixed Pattern Noise) are to be corrected at the factory tuning.

5.18 Image Buffer

Camera stores images temporarily in image buffer, and read them out in arbitrary timing.

5.19 User Free Memory

A free memory area is available to read and write arbitrary data for user. Individual numbers can be assigned when multiple BU cameras are connected.

5.20 Test Pattern

Following test patterns are available.

- Black : Full screen 0 LSB (@ 8-bit)
- White : All pixels 255 LSB (@ 8-bit)
- Grey A : Full screen 170 LSB (10101010_B) (@ 8-bit)
- Grey B : Full screen 85 LSB (01010101_B) (@ 8-bit)
- Horizontal ramp waveform
- Vertical ramp waveform
- Grey scale (B/W model only)
- Color bars (Color model only)

6. Specifications

6.1 Electrical specification

Model Name	BU205M	BU406M
Imager	CMOS image sensor	
Number of active pixels (H) x (V)	2048 x 1088	2048 x 2048
Scanning area (H) x (V) [mm]	11.26 x 5.98 (2/3 type)	11.26 x 5.98 (1/1 type)
Pixel size (H) x (V) [μm]	5.5 x 5.5	
Scan method	Progressive	
Electronic shutter method	Global shutter	
Aspect ratio	2:1	1:1
Standard sensitivity	3800lx F8, 1/200s	3500lx F11, 1/90s
Minimum sensitivity	F1.4, Gain x8, Video level 50%	
	8lx	4lx
Gain	MANUAL (Digital gain)	
Setting range	X1 to x8 (factory setting : x1)	
Black Level	-25 to 25% (factory setting : 0% [0LSB@8bit])	
Gamma	$\gamma=1.0$ to 0.45 (factory setting : $\gamma=1.0$)	
LUT	Input 10 bit, Output 10 bit	
Image Buffer	64M Byte	
User Setting Memory	15 channels	
User Free Memory	64 Byte	
Test Pattern	Black, White, Grey A, Grey B Horizontal ramp waveform, Vertical ramp waveform Grey scale (factory setting : OFF)	
Power supply	DC +5V \pm 5% (from USB connector)	
Power consumption(*1)	2.7W (maximum)	

Model Name	
Without IR-cut filter	BU406MC
With IR-cut filter	BU406MCF
Imager	CMOS image sensor
Number of active pixels (H) x (V)	2048 x 2048
Scanning area (H) x (V) [mm]	11.26 x 11.26 (1/1 type)
Pixel size (H) x (V) [μ m]	5.5 x 5.5
Color filter	RGB primary color mosaic-on-tip color filter
Scan method	Progressive
Electronic shutter method	Global shutter
Aspect ratio	1:1
Standard sensitivity(*2)	4800lx, F8. 1/90s
Minimum sensitivity	F1.4, Gain x8, Video level 50% 10lx
Gain	MANUAL (Digital gain)
Setting range	X1 to x8 (factory setting : x1)
Black Level	-25 to 25% (factory setting : 0% [0LSB@8bit])
Gamma	$\gamma=1.0$ to 0.45 (factory setting : $\gamma=1.0$)
White balance	MWB, OPWB (factory setting : MWB)
Effective range	Without IR-cut filter : N/A With IR-cut filter : 2,500~6,500K
MWB setting format	R/B gain independent setting
OPWB effective area	Full pixel
LUT	Input 10 bit, Output 10 bit
Image Buffer	64M Byte
User Setting Memory	15 channels
User Free Memory	64 Byte
Test Pattern	Black, White, Grey A, Grey B Horizontal ramp waveform, Vertical ramp waveform Color bars (factory setting : OFF)
Power supply	DC +5V \pm 5% (from USB connector)
Power consumption(*1)	2.7W (maximum)

(*1) at the all pixel readout

(*2) with IR-cut filter

6.2 Internal sync signal specification

Fundamental clock frequency	48.000MHz±100ppm
-----------------------------	------------------

6.3 Electronic shutter specification

Exposure time	MANUAL
MANUAL	30μs to 16s
Exposure time Accuracy	±3μs (in overlap exposure operation)

6.4 Random Trigger Shutter specification

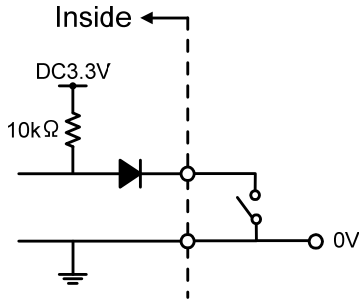
Trigger Mode	External trigger, Software trigger (factory setting : External trigger)
External trigger	Input via I/O connector
Input circuit	
Input level	Low: 0 to 0.5V, High: 2.0 to 24.0V
Polarity	High active / Low active (factory setting : Low active)
Pulse width	50μs (minimum)
Input impedance	High impedance
Software trigger	USB3 Vision command control
Exposure time	Edge mode, Level mode (factory setting : Edge mode)
Edge mode	The exposure time depends on the MANUAL Exposure time setting
Level mode	The exposure time depends on External trigger width
Bulk mode	The exposure time depends on the MANUAL Exposure time setting
Number of Exposures in Bulk mode	255 times (maximum)
Sequential Shutter	16 entries (maximum)
Trigger Delay	0 to 2000000μs (factory setting : 0μs)
AntiGlitch	90ns to 2ms (factory setting : 90ns)
AntiChattering	2us to 2ms (factory setting : 2us)

External trigger input recommended circuit:

1) Isolated I/F

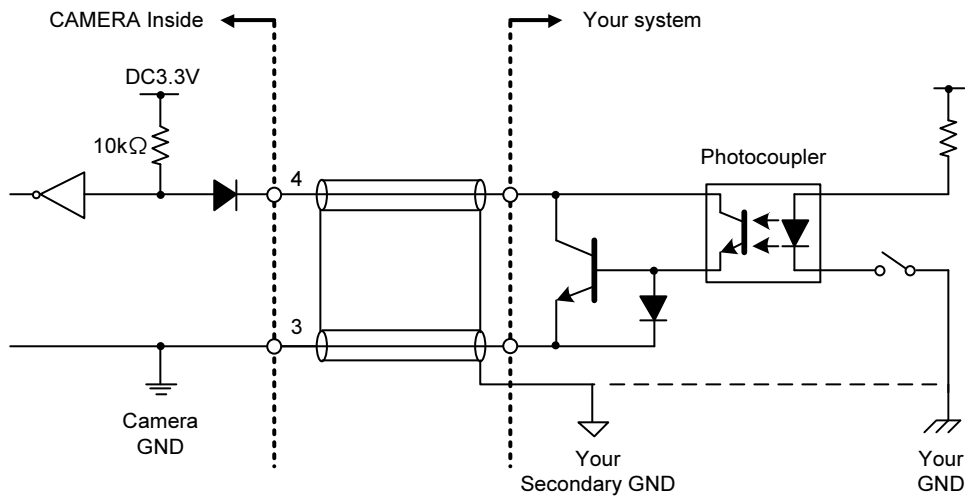

2) Non-isolated I/F

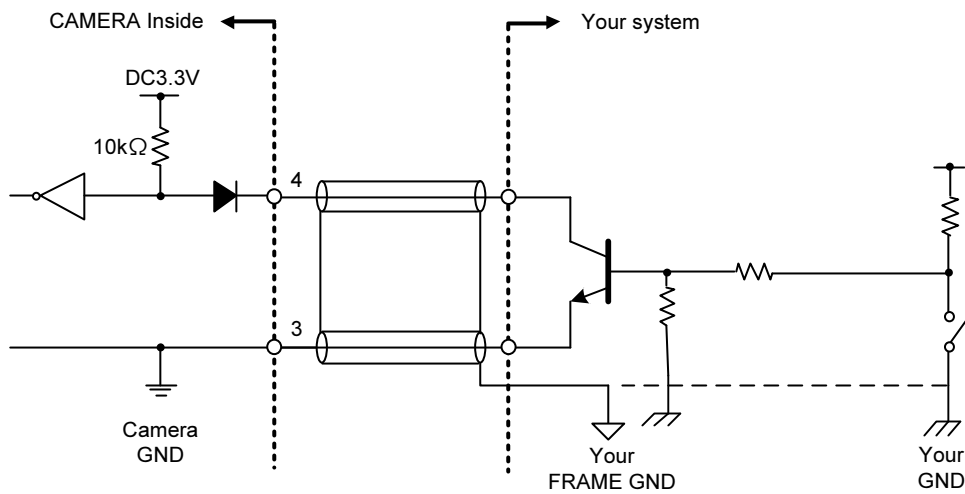

- The recognition of the trigger signal depends on the length, characteristic or driving current of the cable. Therefore please confirm your system about those conditions.
- Pin 3 is signal ground. It isn't conducted with camera frame.
Using shield cable, terminal processing of the shield is referred as above.
- Please confirm the EMC adaptability in whole of your system.

6.5 GPIO Output signal specification

Output channel	2 channels
Output signal	TIMER0 ACTIVE, USER OUTPUT, EXPOSURE ACTIVE, FRAME ACTIVE, FRAME TRANSFER, FRAME TRIGGER WAIT
Output level	5V CMOS
Maximum Current	+/-32mA
Polarity	High active / Low active (factory setting : Low active)
Timer0 Active	
Delay	0 to 2000000 μ s (factory setting : 0 μ s)
Duration	0 to 2000000 μ s (factory setting : 0 μ s)
TimerTriggerSource	Line0Active, ExposureStart, FrameTrigger

6.6 Interface specification

Interface	USB 3.0 (Only SuperSpeed is supported)
Transmission speed	5Gbps (Maximum)
Protocol	USB3 Vision

6.7 LED states

Camera state	Lamp indication
No power	Off
Link detection in progress	Fast flash green (ON:20ms, OFF:60ms)
Connection Error	Flash alternate red / green
SuperSpeed connected, but no data being transferred	Flash green (ON: 200ms, OFF: 800ms)
SuperSpeed connected, waiting for trigger	Flash orange (ON: 200ms, OFF: 800ms)
Data being transferred	Solid Green
Error during data transfer	Solid Red (Time period: 500ms)
Stand-by	Super slow flash orange (ON:200ms, OFF: 2800ms)

6.8 Image output format

	BU205M	BU406M
Image output format	Mono 8 bit	
Frame rate (at the all pixel readout)	Maximum 170 fps	Maximum 90 fps

	BU406MC
Image output format	Bayer 8 bit
Frame rate (at the all pixel readout)	Maximum 90 fps

Notes on Dropping Frames:

- Depends on your PC or USB interface card configurations, images may not be captured normally (e.g. dropping frames may occur). In this case, change to frame rate setting lower.

6.9 Event notification

Event name	FrameTrigger, FrameTriggerError, FrameTriggerWait FrameTransferStart, FrameTransferEnd ExposureStart, ExposureEnd Timer0Start, Timer0End
Event notification delay	approx. 10us later from the event occurs
Time stamp unit	16.7ns (60.0MHz)

6.10 Machine external specification

Dimensions	29 mm(W) * 29 mm (H) * 16 mm (D) (Not including protrusion)
Mass	approx. 32g
Lens mount	C-mount
Flange back	17.526mm
Camera body grounding insulation status	Non-Conductive between circuit GND and camera body

6.11 Operation Ambient conditions

Operation assurance	Temperature: 0°C to +40 °C, Camera housing temperature: less than 50 °C Humidity: 10% to 90% (no condensation)
Storage assurance	Temperature : -20 °C to +60 °C Humidity : +90% or less (no condensation)
EMC condition	EMI (Electro-Magnetic interference) : EN61000-6-4, FCC Part 15 Subpart B Class A EMS (Electro-Magnetic susceptibility) : EN61000-6-2

Notes on Heat Dissipation:

The temperature of camera housing must be kept less than 50 °C in principle.
However, about the upper limit of top surface temperature of camera housing and the allowed ambient temperature of each model, please refer to the "Thermal design manual" on our HP.

Notes on Conformity of the EMC:

The adaptability of the safety standard of this camera is assured in the condition of combination with the following parts:

- USB Cable USB3C-A/1-CS/1-C-0 (COMOSS Electronic Co., Ltd.)
- e-CON Cable 3.0m, Shield cable (Fabricated parts)

Parts:

- e-CON connector XN2A-1470 (OMRON Corporation)
- Shielded wire UL1533 (AWG28) (Hitachi Cable, Ltd.)

Connection:

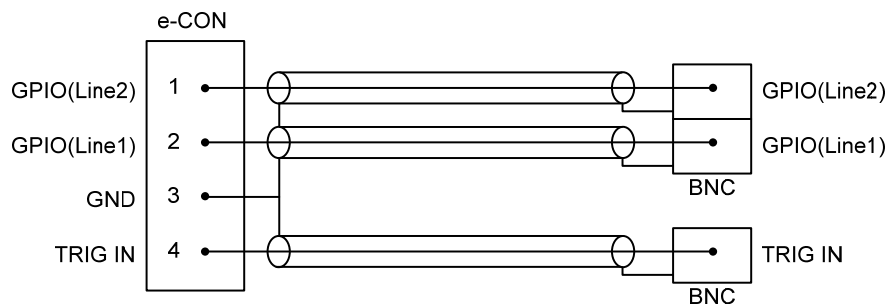

Please confirm the EMC adaptability when it combines with parts other than them.

6.12 Connector pin assignment

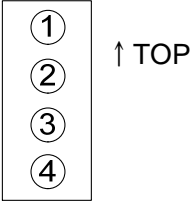
USB 3.0 interface connector			
Connector model: WMUR-10F6L1PH5N (WIN WIN PRECISION INDUSTRIAL)			
Pin No.	I/O	Signal Name	Function
1	-	VBUS	Power
2	I/O	D-	USB2.0 differential pair
3	I/O	D+	
4	-	NC	Not connected
5	-	GND	Ground for power return
6	O	SSTX-	SuperSpeed transmitter differential pair
7	O	SSTX+	
8	-	GND_DRAIN	Ground for SuperSpeed signal return
9	I	SSRX-	SuperSpeed receiver differential pair
10	I	SSRX+	
I/O Connector			
Connector (Camera side)		37204-62B3-004PL (Sumitomo 3M) or equivalent	
Matching connector (Cable side)		Connectors which conformed to e-CON e.g. 37104 series (Sumitomo 3M), RITS 4P series (Tyco)	
* Matching connector is not an accessory of this product.			
Pin assignment			
			
* Above figure is connector view from insert side.			
Pin No.	I/O	Signal Name	Function
1	O	GPIO(Line2)	GPIO Output
2	O	GPIO(Line1)	GPIO Output
3	-	GND	Ground
4	I	TRIG_IN	Trigger Input

6.13 Typical spectral response

The lens characteristics and light source characteristics is not reflected in table.

<BU205M / BU406M>

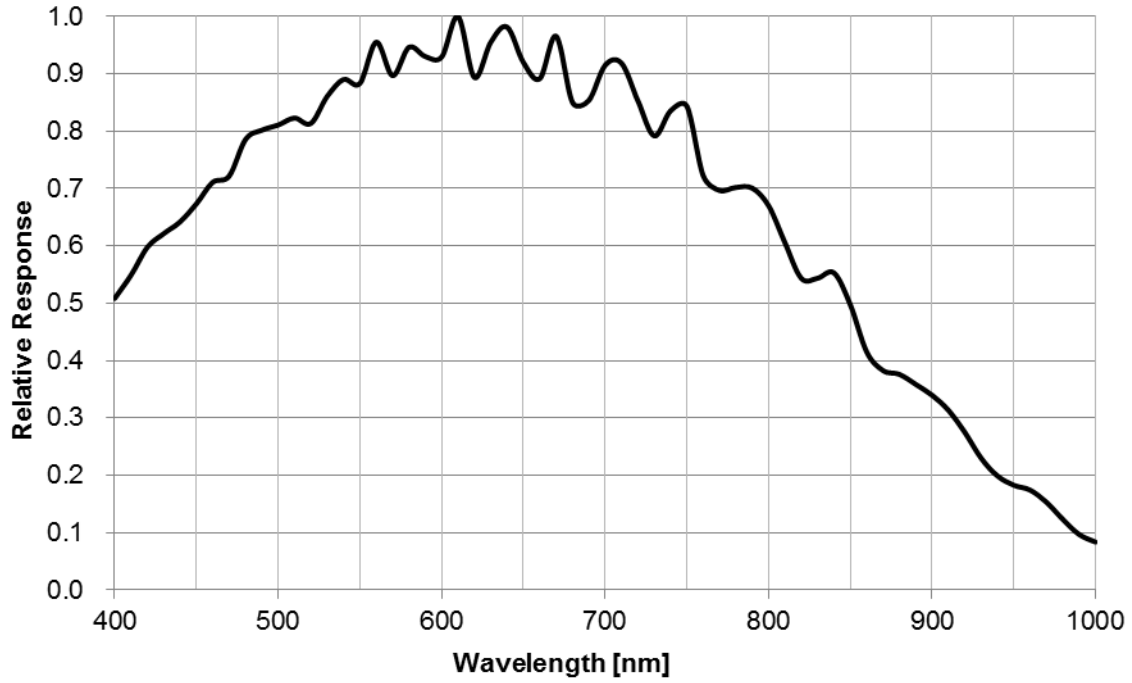

<BU406MC>

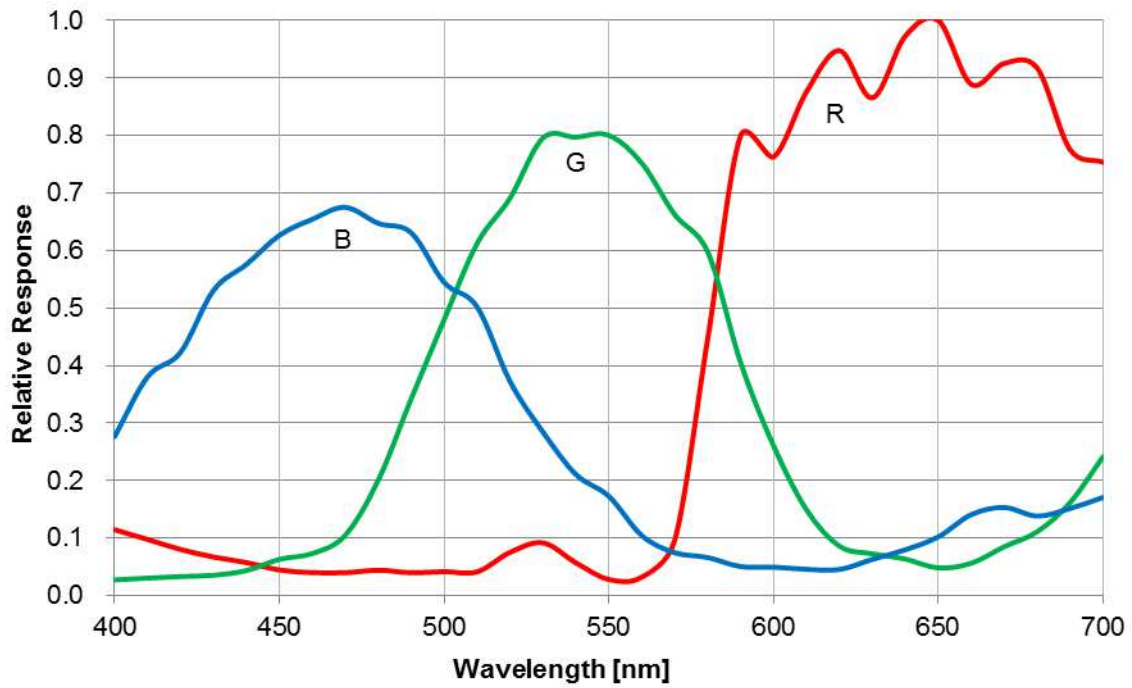

<BU406MCF>

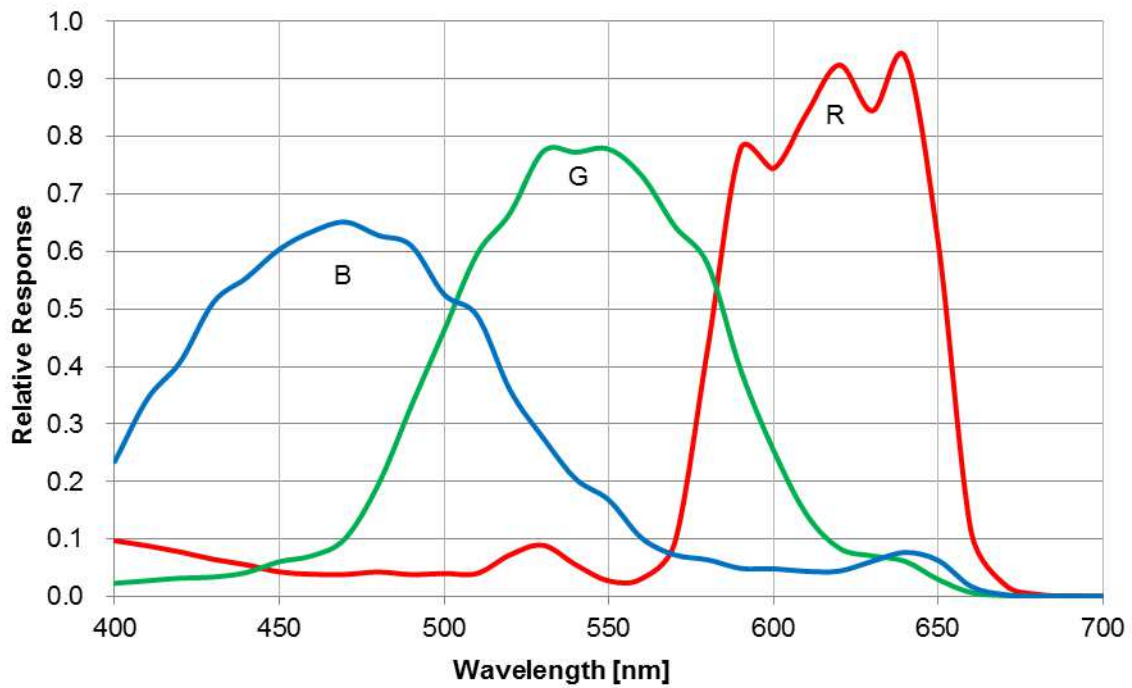

7. Timing chart

Image data outputs are transferred with USB bulk transfer. Timing numerical value below is described by absolute prerequisite that camera can use transmission band without restriction of other device. When there is other device on the same bus, the value described below is not guaranteed.

7.1 In Manual shutter mode (at all pixels readout)

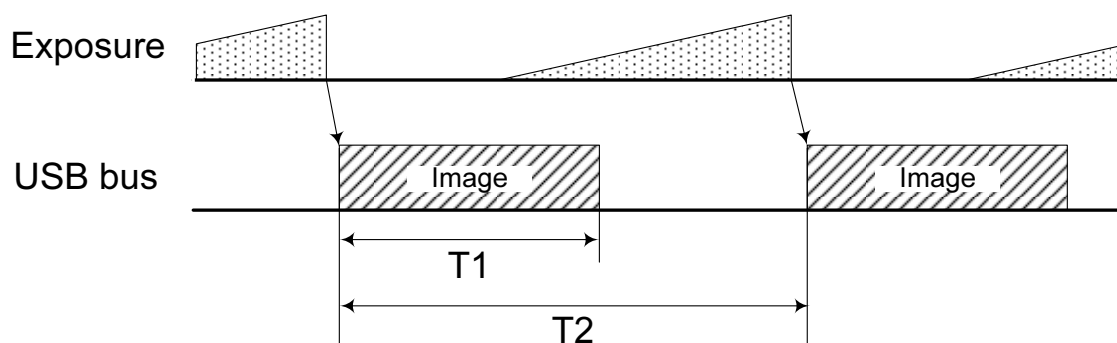

Model Name	T1 [ms]	T2 [ms]	Default Frame Rate [ms]
BU205M	5.9	Frame Rate setting by the application.	5.9
BU406M/C	11.1		11.1

* If the value of T2 is not set by the application, it will be the same as T1.

7.2 In Random Trigger Shutter mode

- Edge mode / Bulk mode (at all pixels readout)

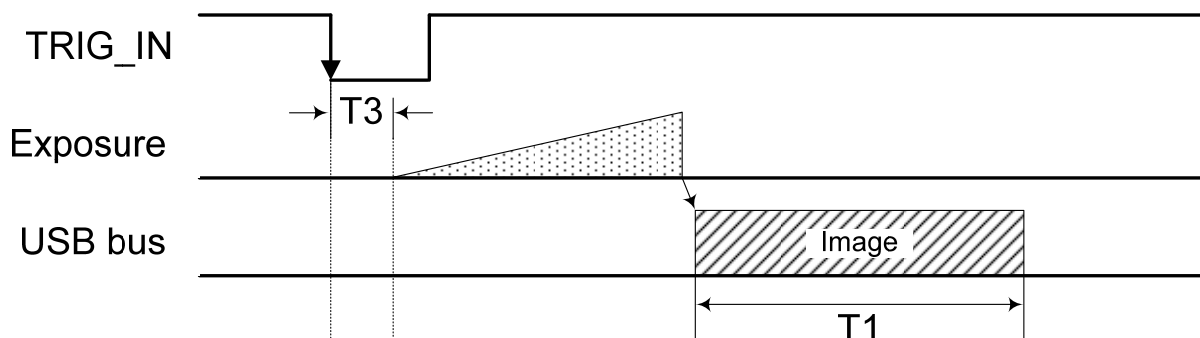

- Level mode (at all pixels readout)

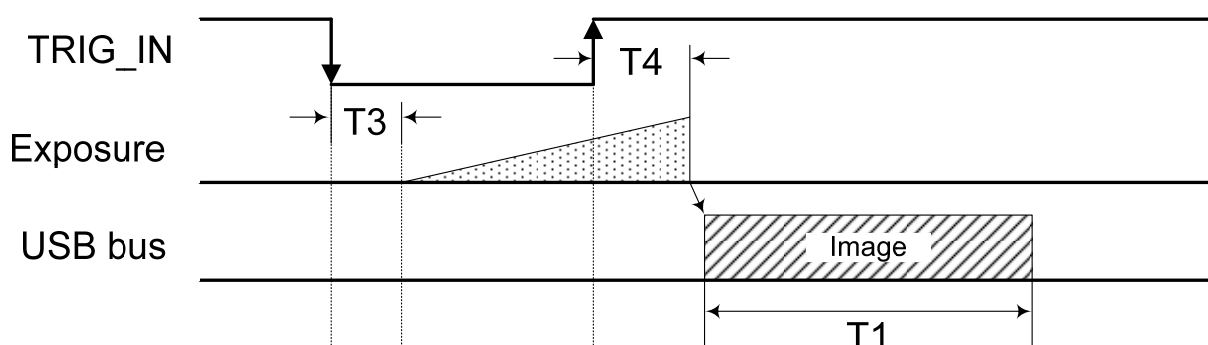

Model Name	T3 [μ s]	T4 [μ s]
BU205M	0.4	0.4
BU406M/C	0.4	0.4

* The value of T1 and T2 are the same as the value of normal shutter mode.

* T3 and T4 are typical value.

Notes of Random Trigger Shutter mode:

- In the period when FRAME_TRIGGER_WAIT (refer to GPIO output signals) signal is inactive, user must not input external trigger signal to this camera.
- When the interval of the input trigger signal is extremely short, or when the trigger signal is noisy, there is a possibility of causing the malfunction. In this case, please input a proper trigger signal.

8. Warranty rules

8.1 Warranty term

Warranty term is 36 months after your purchase. We may assume the date of the purchase from our shipping date when the date is unidentified.

8.2 Limited Warranty

Free warranty is not applicable for the troubles, damages or losses caused by the cases of the followings, even if it is during the warranty term.

1. Natural exhaust, wear or degradation of a component parts
2. Handling against the instructions and conditions described in the instruction manual
3. Remodeling, adjustment and the part exchange. (including the opening of the enclosure box and the alteration)
4. Using the accessories not included with the product or our non-designated optional articles
5. Damages caused during the transportation or deficiency of the handling such as drop or fall of the products after the products having been transferred to customers, leaving the products to corrosive environment such as sunlight, fire, sand, soil, heat, moisture, or an inappropriate storing method
6. A fire, an earthquake, a flood, a lightning, or other natural disasters, pollution and a short circuit, abnormal voltage, excessive physical pressure, theft, other accident
7. When connected to a product which is not recommended
8. When connected to the power supply which is not suitable
9. Forgery product, products which does not have proper serial number, products of which serial number is forged, damaged or deleted
10. All defects that happened after the expiration for a warranty term

9. Repair

9.1 Repair Methods

Basically, has to return it to our company when the user requests us to repair product.

In the case, exchange to a replacement or an equal function product.

9.2 Repair request methods

On the occasion of a repair request, please return the defective product with the failure situation report sheet to be filled out.

Please read the following instructions carefully.

1. Please return our product alone, taking out of your equipment in case that our product is installed to an equipment
2. We are unable to return the information such as your own serial numbers, control number, the identification seal, if it is attached to the returned products. Please keep record before you return the product.
3. As the data saved in the camera will not be kept after the repair, please take out data before return.
4. We are unable to accept the cancellation after the repair request by the customer's reason.
5. About the repair product shipping expenses, please bear the charges when you return the product to us. We bear the charges to you from us only for a warranty period.
6. We are unable to accept your request of a delivery date and time of the product return, or the delivery method.
7. We are unable to accept a trouble factor investigation, the request of the repair report.
8. We accept a repair of out of warranty product, if it is repairable.
9. The proprietary rights of the repair request products after the exchange repair belong to us.
10. The immunity from responsibility of the product is applied in the repair completion products.

* Please refer for the inquiry about the software to our homepage or sales personnel.

10. Outline Drawing

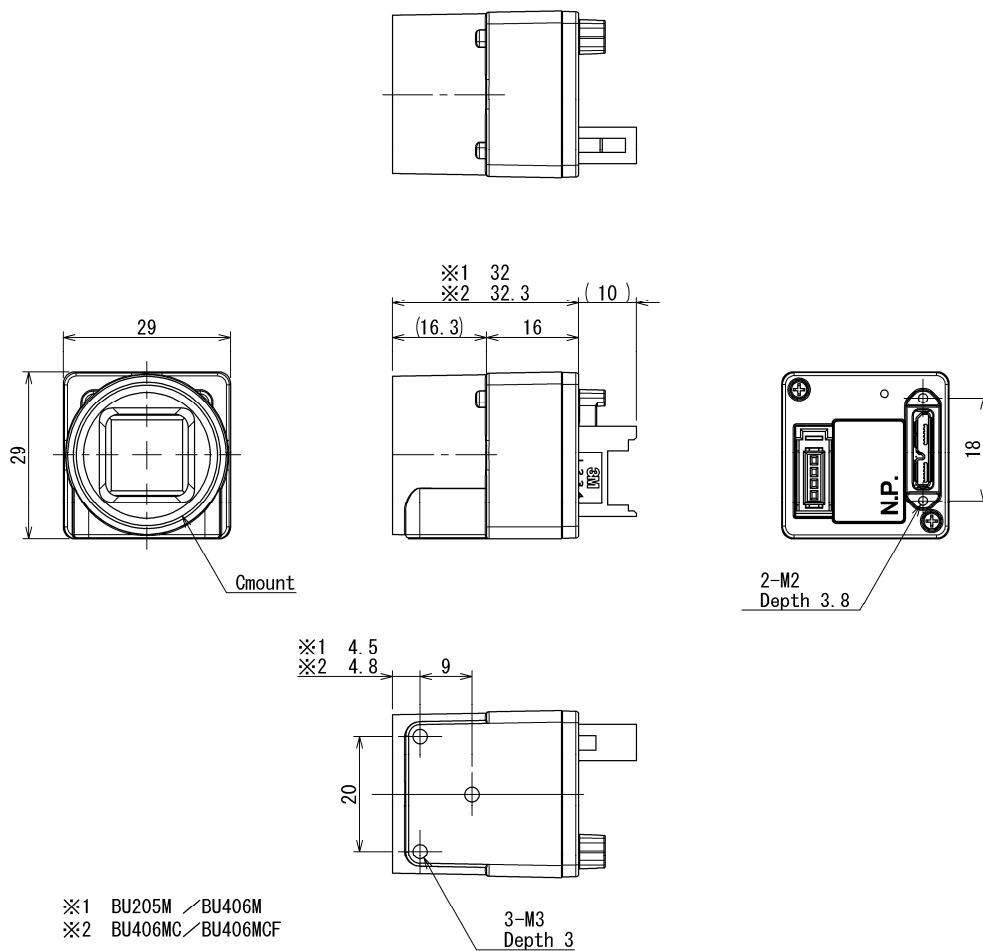

Specification

Main material : Aluminum die-cast metal
 Processing : Cation coating (black)

In order to grasp the details of failure, please fill out the following information, and send us the defective product with this report sheet enclosed.

(1) Customer information

Company Name		Department	Your Name
Telephone number	E-Mail address		FAX number
Postal code number	Address		

(2) Return address Please fill out this information, if the return address is different from above address (1).

The offered personal information is not used for any purposes other than after-sale service, such as repair of a product and an inquiry, and the questionnaire of the improvement in customer satisfaction. Moreover, except for the case where it commissions within limits required for the above-mentioned purpose achievement, it does not indicate to a third party without a visitor's consent. We pay careful attention and manage a visitor's information.

(3) We suggest a possible solution before your repair request.

Please ensure your safety when you check following items.

Please handle power supply with proper procedure, and make sure it does not impede any operation.

a) Restart the power supply of this product.	Check → <input type="checkbox"/> Tried <input type="checkbox"/> Not Tried
Please turn off this product once, switch on a power supply again after passing for a while, and confirm operation.	
b) Exchange for other products.	Check → <input type="checkbox"/> Tried <input type="checkbox"/> Not Tried
Please exchange for other same products, and confirm operation.	
c) Connect to other PC systems.	Check → <input type="checkbox"/> Tried <input type="checkbox"/> Not Tried
Please connect this product to other PCs, and confirm operation.	
d) Check Specifications of this product.	Check → <input type="checkbox"/> Tried <input type="checkbox"/> Not Tried
Please confirm that specifications of this product conform to usage environment referring to following URL.	
URL:http://www.toshiba-teli.co.jp/index.htm	Please check our website for the latest information.

(4) Failure situation

■ Accrual date

Model name	Serial No.	Your dealer
		Purchase date
Failure condition: (Please fill out the phenomenon in detail.)		

(5) From when

- Unknown From the beginning After a while
 After environment was changed.

(Others _____)

(6) Occurrence frequency

- Unknown It certainly occurs. It sometimes occurs.
 It occurs, after time passes.

(Others _____)

<For dealer use>

Reception date :

Receipt No. :

JOB No. :

Check :