

## isc Silicon NPN Power Transistor

## BU4525AX

## DESCRIPTION

- Collector-Emitter Sustaining Voltage-  
:  $V_{CEO(SUS)} = 800V$  (Min)
- High Switching Speed

## APPLICATIONS

- Designed for use in horizontal deflection circuits of color TV receivers and PC monitors.

ABSOLUTE MAXIMUM RATINGS( $T_a=25^\circ C$ )

SYMBOL	PARAMETER	VALUE	UNIT
$V_{CES}$	Collector- Emitter Voltage( $V_{BE} = 0$ )	1500	V
$V_{CEO}$	Collector-Emitter Voltage	800	V
$V_{EBO}$	Emitter-Base Voltage	7.5	V
$I_C$	Collector Current- Continuous	12	A
$I_{CM}$	Collector Current-Peak	30	A
$I_B$	Base Current- Continuous	8	A
$I_{BM}$	Base Current-Peak	12	A
$P_C$	Collector Power Dissipation @ $T_C=25^\circ C$	45	W
$T_J$	Junction Temperature	150	$^\circ C$
$T_{stg}$	Storage Temperature Range	-55~150	$^\circ C$

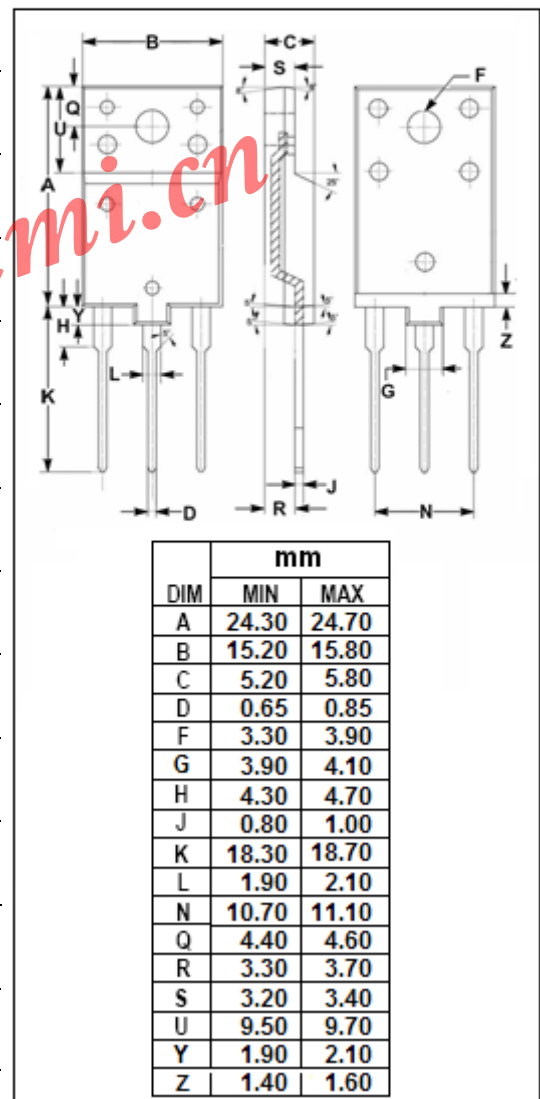
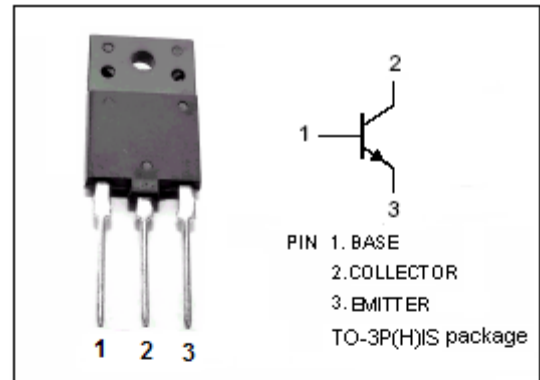

## THERMAL CHARACTERISTICS

SYMBOL	PARAMETER	MAX	UNIT
$R_{th\ j-c}$	Thermal Resistance, Junction to Case	2.8	$^\circ C/W$

**isc Silicon NPN Power Transistor****BU4525AX****ELECTRICAL CHARACTERISTICS** $T_C=25^{\circ}\text{C}$  unless otherwise specified

SYMBOL	PARAMETER	CONDITIONS	MIN	TYP.	MAX	UNIT
$V_{CEO(SUS)}$	Collector-Emitter Sustaining Voltage	$I_C=100\text{mA}$ ; $I_B=0$ , $L=25\text{mH}$	800			V
$V_{(BR)EBO}$	Emitter-Base Breakdown Voltage	$I_E=1\text{mA}$ ; $I_C=0$	7.5			V
$V_{CE(sat)}$	Collector-Emitter Saturation Voltage	$I_C=9\text{A}$ ; $I_B=2.25\text{A}$			3.0	V
$V_{BE(sat)}$	Base-Emitter Saturation Voltage	$I_C=9\text{A}$ ; $I_B=2.25\text{A}$			1.06	V
$I_{CES}$	Collector Cutoff Current	$V_{CE}=1500\text{V}$ ; $V_{BE}=0$ $V_{CE}=1500\text{V}$ ; $V_{BE}=0$ ; $T_C=125^{\circ}\text{C}$			1.0 2.0	mA
$I_{EBO}$	Emitter Cutoff Current	$V_{EB}=6\text{V}$ ; $I_C=0$			0.1	mA
$h_{FE-1}$	DC Current Gain	$I_C=1\text{A}$ ; $V_{CE}=5\text{V}$		12		
$h_{FE-2}$	DC Current Gain	$I_C=9\text{A}$ ; $V_{CE}=5\text{V}$	4.2		7.6	

Switching times (16kHz line deflection circuit)

$t_{stg}$	Storage Time	$I_C=9\text{A}$ , $I_{B1}=1.8\text{A}$ ; $I_{B2}=-4.5\text{A}$			4.5	$\mu\text{s}$
$t_f$	Fall Time				0.55	$\mu\text{s}$