

Structure Silicon Monolithic Integrated Circuit

Product Name Audio Interface for Cellular Phone

Product No. **BU7843AGU**

Features Audio Interface  
6x6 keyscan circuit

○Absolute Maximum Ratings(Ta=25 °C)

Parameter	Symbol	Rating	Unit	Remarks
Analog supply voltage	AVDD	-0.3~4.5	V	
Digital supply voltage	DVDD	-0.3~4.5	V	
Power supply voltage	PVDD	-0.3~4.5	V	
Analog input voltage	V <sub>AIN</sub>	AVSS-0.3~AVDD+0.3	V	
Digital input voltage	V <sub>DIN</sub>	DVSS-0.3~DVDD+0.3	V	
Input current	I <sub>IN</sub>	-10~+10	mA	
Allowable dissipation	P <sub>d</sub>	310(*1)	mW	
Operating temperature range	T <sub>OPR</sub>	-30~+85	°C	
Storage temperature range	T <sub>STG</sub>	-55~+125	°C	

(\*1) When Ta is above 25°C, reduce 3.1mW per 1°C.

○Recommended operating conditions (Ta=25 °C)

Parameter	Symbol	Rating			Unit	Remarks
		Min.	Typ.	Max.		
Analog operation voltage	AVDD	2.7	2.8	3.1	V	(*2)
Digital operation voltage	DVDD	1.65	1.8	3.1	V	
Power operation voltage	PVDD	2.7	2.8	3.1	V	

(\*2) AVDD and PVDD are internally connected in the IC and use the same potential.

This chip is not designed to protect itself against radioactive rays.

Status of this document

The Japanese version of this document is the formal specification. A customer may use this translation version only for a reference to help reading the formal version. If there are any differences in translation version of this document, formal version takes priority.

Application example

The product described in this specification is designed to be used with ordinary electronic equipment or devices(such as audio-visual equipment, office-automation equipment, communications devices, electrical appliances, and electronic toys).

Should you intend to use this product with equipment or devices which require an extremely high level of reliability and the malfunction of which would directly endanger human life(such as medical instruments, transportation equipment, aerospace machinery, nuclear-reactor controllers, fuel controllers and other safety devices), please be sure to consult with our sales representative in advance.

○Electrical Characteristics

(Unless otherwise noted, Ta = 25°C AVSS=DVSS=PVSS=0.0V ATT is set at 0)

Parameter	Symbol	Rating			Unit	Condition
		Min.	Typ.	Max.		
Digital DC characteristics						
Digital high level input voltage 1	V <sub>IH1</sub>	0.8 DVDD	-	-	V	DVDD=3.0V
Digital high level input voltage 2	V <sub>IH2</sub>	DVDD -0.4	-	-	V	DVDD=1.8V
Digital low level input voltage 1	V <sub>IL1</sub>	-	-	0.2 DVDD	V	DVDD=3.0V
Digital low level input voltage 2	V <sub>IL2</sub>	-	-	0.4	V	DVDD=1.8V
Digital high level input current	I <sub>IH</sub>	-	-	1	μA	V <sub>IH</sub> =DVDD
Digital low level input current	I <sub>IL</sub>	-	-	1	μA	V <sub>IL</sub> =DVSS
Digital high level output voltage	V <sub>OH</sub>	DVDD -0.5	-	-	V	I <sub>OH</sub> =-1mA
Digital low level output voltage	V <sub>OL</sub>	-	-	0.5	V	I <sub>OL</sub> =1mA
Digital AC characteristics						
SCL clock frequency	f <sub>SCL</sub>	-	-	400	kHz	
Bus free time	t <sub>BUF</sub>	1.3	-	-	μs	
(Iterative) start condition setup time	t <sub>SU;STA</sub>	0.6	-	-	μs	
(Iterative) start condition hold time	t <sub>HD;STA</sub>	0.6	-	-	μs	
SCL low time	t <sub>LOW</sub>	1.3	-	-	μs	
SCL high time	t <sub>HIGH</sub>	0.6	-	-	μs	
Data setup time	t <sub>SU;DAT</sub>	100	-	-	ns	
Data hold time	t <sub>HD;DAT</sub>	0	-	-	ns	
Stop condition setup time	t <sub>SU;STO</sub>	0.6	-	-	μs	
Current consumption AVDD=DVDD=PVDD=2.8V input signal = no signal.						
Standby current	I <sub>ST</sub>	-	-	3	μA	After a reset
TX_OUT path current	I <sub>DD1</sub>	-	1.3	2.2	mA	MIC1_IN→MIX6→TX_OUT
HF_OUT path current	I <sub>DD2</sub>	-	1.4	2.4	mA	RX_IN→MIX2→HF_OUT
BT_OUT path current	I <sub>DD3</sub>	-	1.3	2.2	mA	RX_IN→MIX2→BT_OUT
Receiver path current	I <sub>DD4</sub>	-	2.5	4.2	mA	RX_IN→MIX2→RCVP_OUT, RCVN_OUT
Headphone path current	I <sub>DD5</sub>	-	3.5	5.9	mA	DACL_IN→MIX2→HPL_OUT DACR_IN→MIX3→HPR_OUT
Speaker path current	I <sub>DD6</sub>	-	1.9	3.2	mA	DACL_IN→MIX4→SPL_OUT DACR_IN→MIX5→SPR_OUT
Full operation current	I <sub>DD9</sub>	-	8.5	13.5	mA	All paths are ON
Microphone bias current	I <sub>DD8</sub>	-	250	430	μA	BIAS_ON= !

○External measure and View

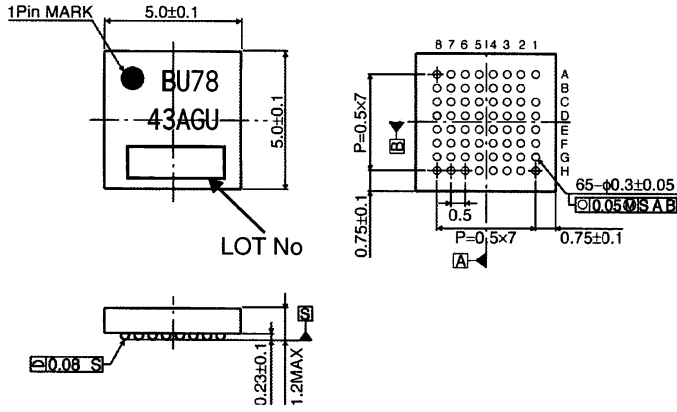

VBGA063T050 (Unit: mm)

○Pin layout diagram

Pin NO.	Pin name	Pin NO.	Pin name	Pin NO.	Pin name
A1	N.C.	F4	KB0	C8	RCVP_OUT
C3	MIC1_IN	H4	DVDD	C7	CPOP
C2	MIC2_IN	G5	DVSS	B8	N.C.
D2	MIC3_IN	F5	KB1	B7	N.C.
C1	AUX1_IN	H5	KB2	A8	N.C.
D3	DACL_IN	E5	KB3	A7	N.C.
D1	AUX2_IN	H6	KB4	C6	SPL_OUT
E2	DACL_IN	G6	KB5	B6	SPR_OUT
E3	RX_IN	H7	N.C.	B5	HF_OUT
E1	SDA	G7	N.C.	A6	BT_OUT
E4	SDL	H8	N.C.	C5	TX_OUT
F1	KBR0	G8	N.C.	A5	COMOUT
F2	KBR1	F6	IRQ	B4	COMIN
G1	N.C.	F7	RSTB	C4	AVDD
G2	N.C.	F8	HPR_OUT	A4	AVSS
H1	N.C.	E6	HPL_OUT	D4	CBIAS
H2	N.C.	E8	CHPL	A3	MIC1_OUT
F3	KBR2	D7	PVSS	B3	MICB
G3	KBR3	D6	PVDD	A2	N.C.
G4	KBR4	D8	RCVN_OUT	B3	N.C.
H3	KBR5	D5	CSTEP		

○Block diagram

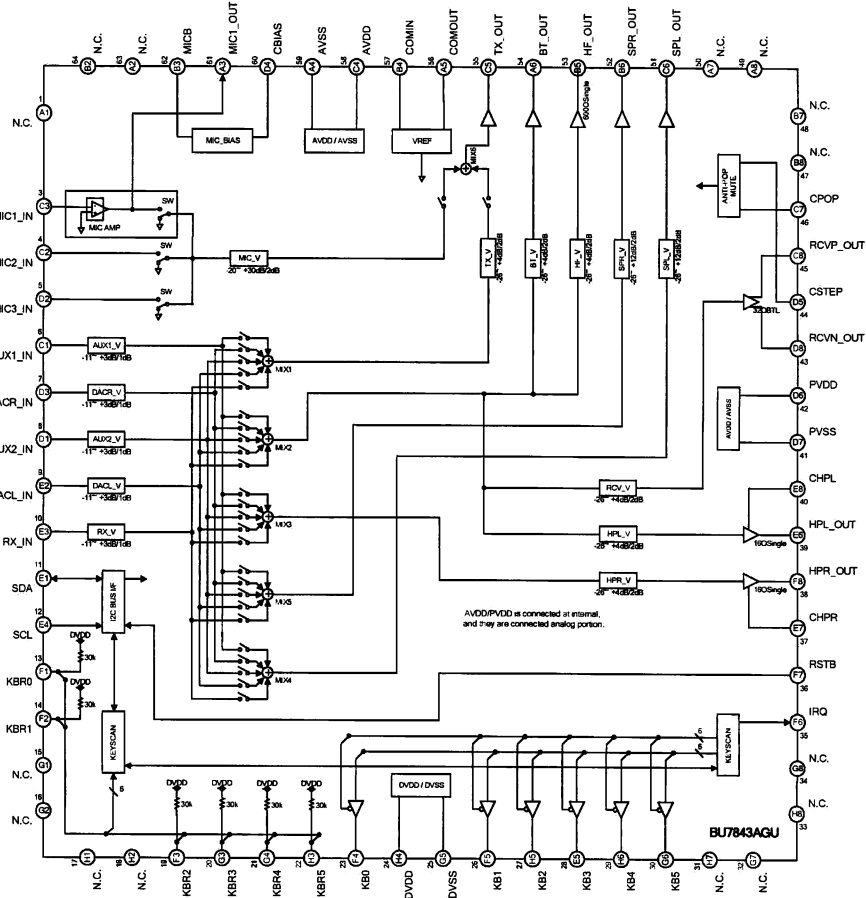

## ○Cautions on use

## (1) Absolute Maximum Ratings

An excess in the absolute maximum ratings, such as supply voltage, temperature range of operating conditions, etc., can break down devices, thus making impossible to identify breaking mode such as a short circuit or an open circuit. If any special mode exceeding the absolute maximum ratings is assumed, consideration should be given to take physical safety measures including the use of fuses, etc.

## (2) Operating conditions

These conditions represent a range within which characteristics can be provided approximately as expected. The electrical characteristics are guaranteed under the conditions of each parameter.

## (3) Reverse connection of power supply connector

The reverse connection of power supply connector can break down ICs. Take protective measures against the breakdown due to the reverse connection, such as mounting an external diode between the power supply and the IC's power supply terminal.

## (4) Power supply line

Design PCB pattern to provide low impedance for the wiring between the power supply and the GND lines. In this regard, for the digital block power supply and the analog block power supply, even though these power supplies have the same level of potential, separate the power supply pattern for the digital block from that for the analog block, thus suppressing the diffraction of digital noises to the analog block power supply resulting from impedance common to the wiring patterns. For the GND line, give consideration to design the patterns in a similar manner.

Furthermore, for all power supply terminals to ICs, mount a capacitor between the power supply and the GND terminal. At the same time, in order to use an electrolytic capacitor, thoroughly check to be sure the characteristics of the capacitor to be used present no problem including the occurrence of capacity dropout at a low temperature, thus determining the constant.

## (5) GND voltage

Make setting of the potential of the GND terminal so that it will be maintained at the minimum in any operating state. Furthermore, check to be sure no terminals are at a potential lower than the GND voltage including an actual electric transient.

## (6) Short circuit between terminals and erroneous mounting

In order to mount ICs on a set PCB, pay thorough attention to the direction and offset of the ICs. Erroneous mounting can break down the ICs. Furthermore, if a short circuit occurs due to foreign matters entering between terminals or between the terminal and the power supply or the GND terminal, the ICs can break down.

## (7) Operation in strong electromagnetic field

Be noted that using ICs in the strong electromagnetic field can malfunction them.

## (8) Inspection with set PCB

On the inspection with the set PCB, if a capacitor is connected to a low-impedance IC terminal, the IC can suffer stress. Therefore, be sure to discharge from the set PCB by each process. Furthermore, in order to mount or dismount the set PCB to/from the jig for the inspection process, be sure to turn OFF the power supply and then mount the set PCB to the jig. After the completion of the inspection, be sure to turn OFF the power supply and then dismount it from the jig. In addition, for protection against static electricity, establish a ground for the assembly process and pay thorough attention to the transportation and the storage of the set PCB.

## (9) Input terminals

In terms of the construction of IC, parasitic elements are inevitably formed in relation to potential. The operation of the parasitic element can cause interference with circuit operation, thus resulting in a malfunction and then breakdown of the input terminal. Therefore, pay thorough attention not to handle the input terminals, such as to apply to the input terminals a voltage lower than the GND respectively, so that any parasitic element will operate. Furthermore, do not apply a voltage to the input terminals when no power supply voltage is applied to the IC. In addition, even if the power supply voltage is applied, apply to the input terminals a voltage lower than the power supply voltage or within the guaranteed value of electrical characteristics.

## (10) Ground wiring pattern

If small-signal GND and large-current GND are provided, it will be recommended to separate the large-current GND pattern from the small-signal GND pattern and establish a single ground at the reference point of the set PCB so that resistance to the wiring pattern and voltage fluctuations due to a large current will cause no fluctuations in voltages of the small-signal GND. Pay attention not to cause fluctuations in the GND wiring pattern of external parts as well.

## (11) External capacitor

In order to use a ceramic capacitor as the external capacitor, determine the constant with consideration given to a degradation in the nominal capacitance due to DC bias and changes in the capacitance due to temperature, etc.

## (12) Others

In case of use this LSI, please peruse some other detail documents, we called , Technical note, Functional description, Application note.

### Notes

- No technical content pages of this document may be reproduced in any form or transmitted by any means without prior permission of ROHM CO.,LTD.
- The contents described herein are subject to change without notice. The specifications for the product described in this document are for reference only. Upon actual use, therefore, please request that specifications to be separately delivered.
- Application circuit diagrams and circuit constants contained herein are shown as examples of standard use and operation. Please pay careful attention to the peripheral conditions when designing circuits and deciding upon circuit constants in the set.
- Any data, including, but not limited to application circuit diagrams information, described herein are intended only as illustrations of such devices and not as the specifications for such devices. ROHM CO.,LTD. disclaims any warranty that any use of such devices shall be free from infringement of any third party's intellectual property rights or other proprietary rights, and further, assumes no liability of whatsoever nature in the event of any such infringement, or arising from or connected with or related to the use of such devices.
- Upon the sale of any such devices, other than for buyer's right to use such devices itself, resell or otherwise dispose of the same, no express or implied right or license to practice or commercially exploit any intellectual property rights or other proprietary rights owned or controlled by
- ROHM CO., LTD. is granted to any such buyer.
- Products listed in this document are no antiradiation design.

The products listed in this document are designed to be used with ordinary electronic equipment or devices (such as audio visual equipment, office-automation equipment, communications devices, electrical appliances and electronic toys).

Should you intend to use these products with equipment or devices which require an extremely high level of reliability and the malfunction of which would directly endanger human life (such as medical instruments, transportation equipment, aerospace machinery, nuclear-reactor controllers, fuel controllers and other safety devices), please be sure to consult with our sales representative in advance.

#### About Export Control Order in Japan

Products described herein are the objects of controlled goods in Annex 1 (Item 16) of Export Trade Control Order in Japan.

In case of export from Japan, please confirm if it applies to "objective" criteria or an "informed" (by MITI clause) on the basis of "catch all controls for Non-Proliferation of Weapons of Mass Destruction.

Thank you for your accessing to ROHM product informations.  
More detail product informations and catalogs are available,  
please contact your nearest sales office.

Please contact our sales offices for details ;

U.S.A / San Diego	TEL : +1(858)625-3630	FAX : +1(858)625-3670
Atlanta	TEL : +1(770)754-5972	FAX : +1(770)754-0691
Dallas	TEL : +1(972)312-8818	FAX : +1(972)312-0330
Germany / Dusseldorf	TEL : +49(2154)9210	FAX : +49(2154)921400
United Kingdom / London	TEL : +44(1)908-282-666	FAX : +44(1)908-282-528
France / Paris	TEL : +33(0)1 56 97 30 60	FAX : +33(0) 1 56 97 30 80
China / Hong Kong	TEL : +852(2)740-6262	FAX : +852(2)375-8971
Shanghai	TEL : +86(21)6279-2727	FAX : +86(21)6247-2066
Dilian	TEL : +86(411)8230-8549	FAX : +86(411)8230-8537
Beijing	TEL : +86(10)8525-2483	FAX : +86(10)8525-2489
Taiwan / Taipei	TEL : +866(2)2500-6956	FAX : +866(2)2503-2869
Korea / Seoul	TEL : +82(2)8182-700	FAX : +82(2)8182-715
Singapore	TEL : +65-6332-2322	FAX : +65-6332-5662
Malaysia / Kuala Lumpur	TEL : +60(3)7958-8355	FAX : +60(3)7958-8377
Philippines / Manila	TEL : +63(2)807-6872	FAX : +63(2)809-1422
Thailand / Bangkok	TEL : +66(2)254-4890	FAX : +66(2)256-6334

Japan /  
(Internal Sales)

Tokyo	2-1-1, Yaesu, Chuo-ku, Tokyo 104-0082	TEL : +81(3)5203-0321	FAX : +81(3)5203-0300
Yokohama	2-4-8, Shin Yokohama, Kohoku-ku, Yokohama, Kanagawa 222-8575	TEL : +81(45)476-2131	FAX : +81(45)476-2128
Nagoya	Dainagayo Building 9F 3-28-12, Meieki, Nakamura-ku, Nagoya, Aichi 450-0002	TEL : +81(52)581-8521	FAX : +81(52)561-2173
Kyoto	579-32 Higashi Shiokouji-cho, Karasuma Nishi-iru, Shiokoujidori, Shimogyo-ku, Kyoto 600-8216	TEL : +81(75)311-2121	FAX : +81(75)314-6559

(Contact address for overseas customers in Japan)

Yokohama	TEL : +81(45)476-9270	FAX : +81(045)476-9271
----------	-----------------------	------------------------