

NPN Power Darlington High Voltage Ignition Coil Driver, 15A, 400V

FEATURES

- NPN Darlington
- Integrated antiparallel Collector-Emitter Diode
- Very rugged bipolar technology
- High operating junction temperature

APPLICATIONS

- High ruggedness electronic ignitions

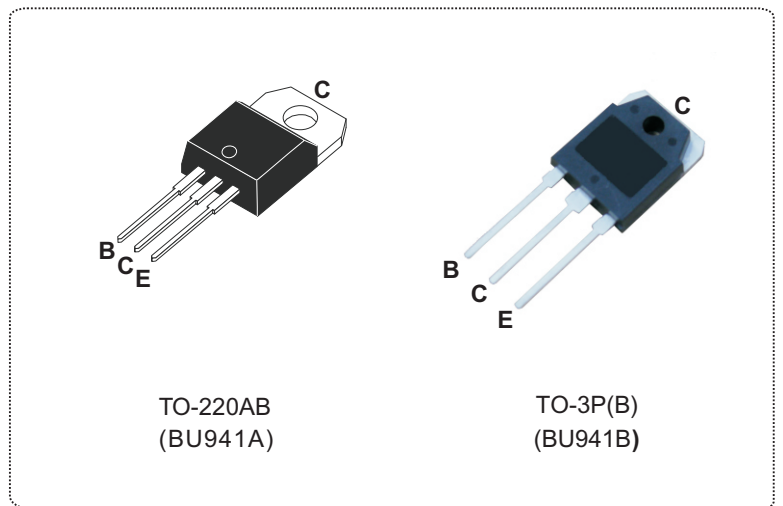

* Internal Schematic Diagram

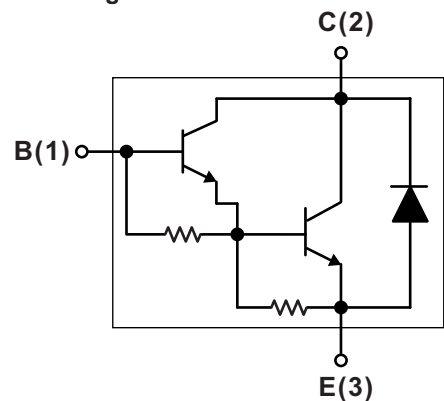

PRODUCT SUMMARY	
I_C (A)	15
V_{CEO} (V)	400
h_{FE}	300 Min.

ABSOLUTE MAXIMUM RATINGS ($T_C = 25^\circ\text{C}$ unless otherwise specified)					
SYMBOL	PARAMETER	TEST CONDITIONS	VALUE	UNIT	
V_{CES}	Collector to Emitter Voltage	$V_{BE}=0$	500	V	
V_{CEO}	Collector to Emitter Voltage	$I_B=0$	400		
V_{EBO}	Emitter to Base Voltage	$I_C=0$	5		
I_C	Collector Current		15	A	
I_{CM}	Collector Peak Current		30		
I_B	Base Current		1.0		
I_{BM}	Base Peak Current		5.0		
P_D	Total power dissipation	TO-220AB	$T_C=25^\circ\text{C}$	150	W
		TO-3P(B)		155	
T_J	Operation junction temperature		-65 to 175	$^\circ\text{C}$	
T_{STG}	Storage temperature		-65 to 175		

THERMAL RESISTANCE						
SYMBOL	PARAMETER		Min.	Typ.	Max.	UNIT
$R_{th(j-c)}$	Thermal resistance, junction to case	TO-220AB			1.00	°C/W
		TO-3P(B)			0.97	

ELECTRICAL CHARACTERISTICS ($T_C = 25^\circ\text{C}$ unless otherwise specified)						
SYMBOL	PARAMETER	TEST CONDITIONS	Min.	Typ.	Max.	UNIT
I_{CES}	Collector cut-off current	$V_{BE}=0, V_{CE}=500\text{V}$			100	μA
		$V_{BE}=0, V_{CE}=500\text{V}, T_j=125^\circ\text{C}$			0.5	mA
I_{CEO}	Collector cut-off current	$I_B=0, V_{CE}=450\text{V}$			100	μA
		$I_B=0, V_{CE}=450\text{V}, T_j=125^\circ\text{C}$			0.5	mA
I_{EBO}	Emitter cut-off current	$I_C=0, V_{EB}=5\text{V}$			20	mA
$V_{CEO(SUS)}^*$	Collector to emitter sustaining voltage	$I_B=0, I_C=100\text{mA}, L=10\text{mH}, V_{clamp}=400\text{V}$	400			V
$V_{CE(sat)}^*$	Collector to emitter saturation voltage	$I_C=8\text{A}, I_B=100\text{mA}$			1.6	
		$I_C=10\text{A}, I_B=250\text{mA}$			1.8	
		$I_C=12\text{A}, I_B=300\text{mA}$			2	
$V_{BE(sat)}^*$	Base to emitter saturation voltage	$I_C=8\text{A}, I_B=100\text{mA}$			2.2	
		$I_C=10\text{A}, I_B=250\text{mA}$			2.5	
		$I_C=12\text{A}, I_B=300\text{mA}$			2.7	
h_{FE}	DC current gain	$I_C=5\text{A}, V_{CE}=10\text{V}$	300			
V_F	Diode forward voltage	$I_F=10\text{A}$			2.5	V
	Functional test	$V_{CC}=24\text{V}, L=7\text{mH}, V_{clamp}=400\text{V}$ (see functional test circuit)	10			A
t_f	Fall time	$V_{CC}=12\text{V}, V_{clamp}=300\text{V}, V_{BE}=0, R_{BE}=47\Omega, L=7\text{mH}, I_C=7\text{A}, I_B=70\text{mA}$		15		μS
t_s	Storage time			0.5		

*Pulsed: Pulse duration= 300 μs , duty cycle= 1.5%.

ORDERING INFORMATION SCHEME	
BU941	A
<p>Darlington series</p> <p>BU941 Type, 15A / 400V</p>	
<p>Package type</p> <p>A = TO-220AB B = TO-3P(B)</p>	

■ **SUSTAINING VOLTAGE TEST CIRCUIT**

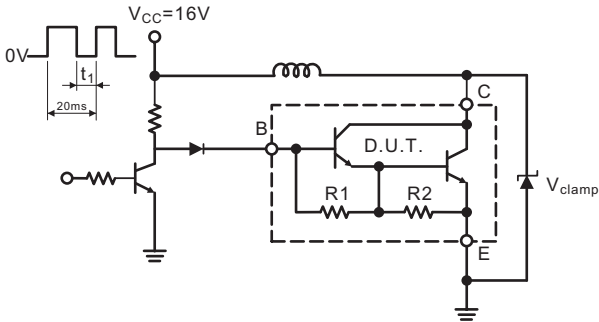

■ **SWITCHING TIME TEST CIRCUIT**

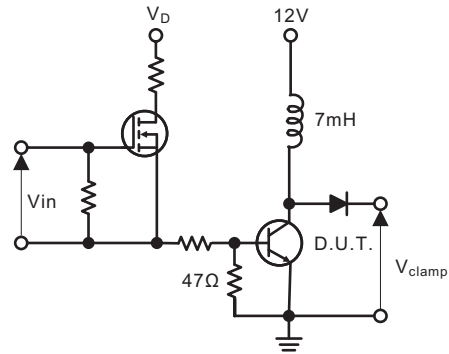

■ **FUNCTION TEST CIRCUIT**

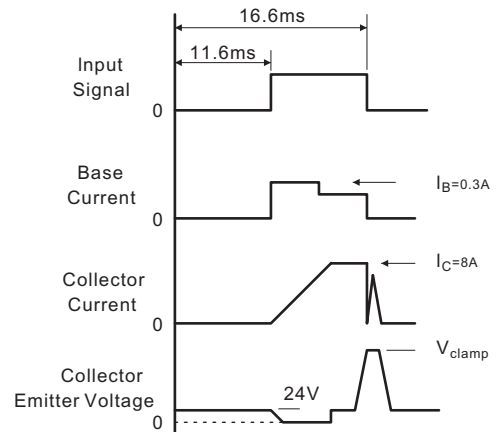
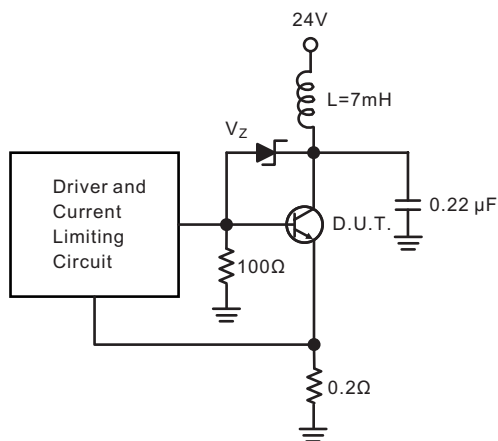

■ **TYPICAL CHARACTERISTICS**

Fig.1 DC Current gain

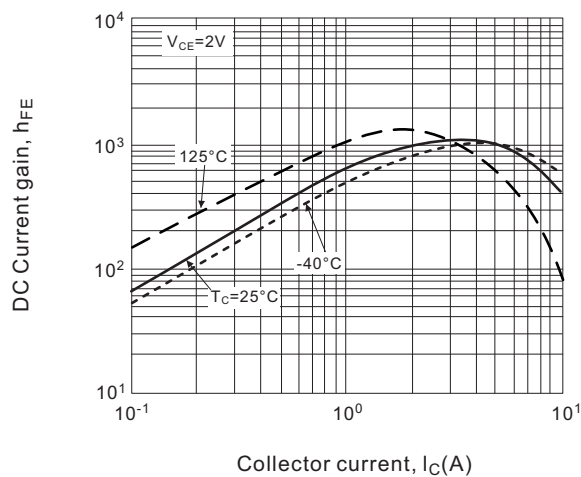

Fig.2 DC Current gain

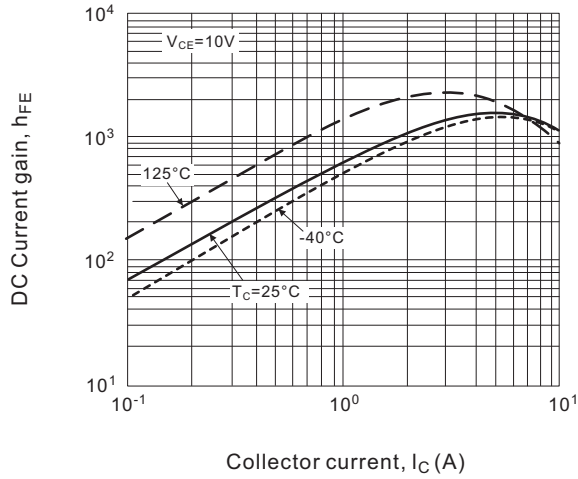

Fig.3 Collector-Emmitter saturation voltage

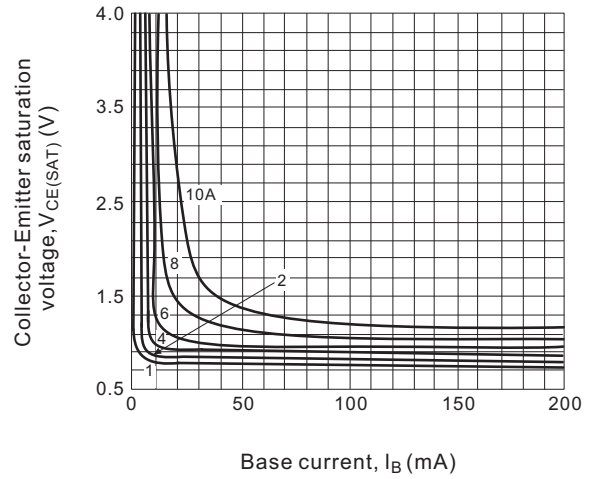

Fig.4 Collector-Emmitter saturation voltage

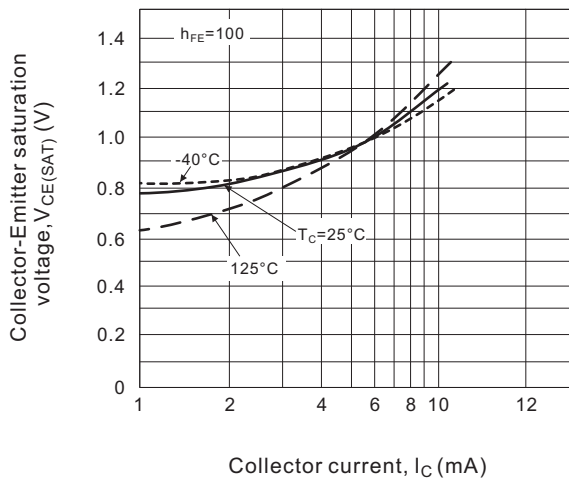

Fig.5 Base-Emmitter saturation voltage

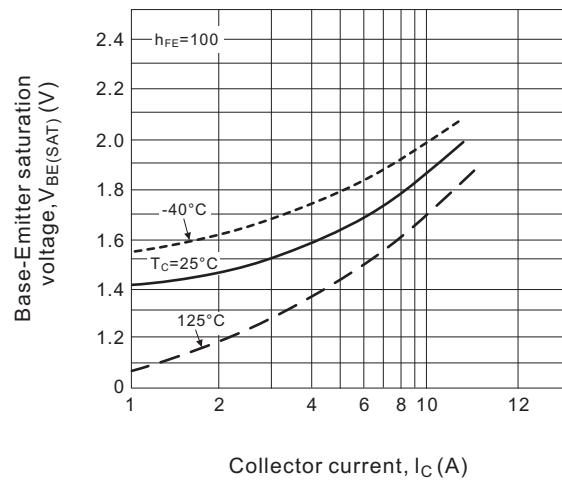

Fig.6 Switching time

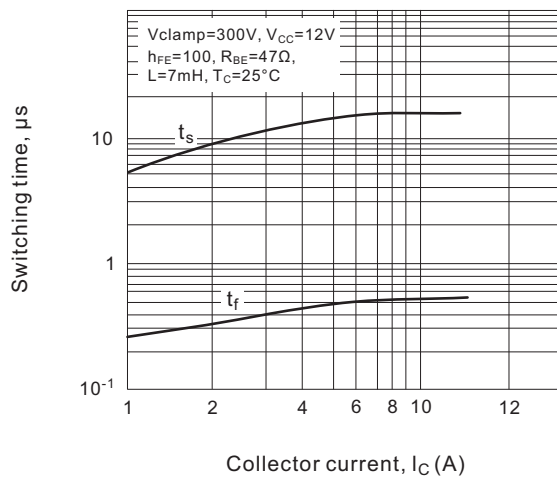
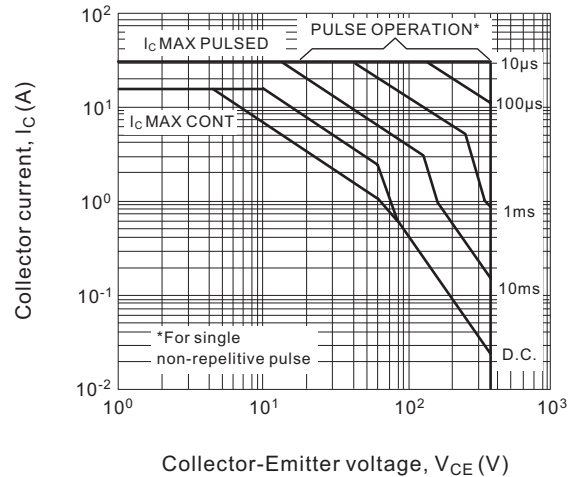
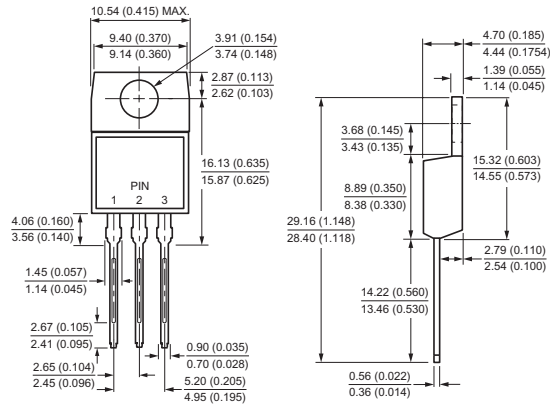

Fig.7 Safe operating area



Case Style

TO-220AB



All dimensions in millimeters(inches)

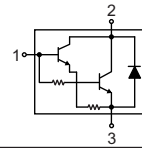

TO-3P(B)

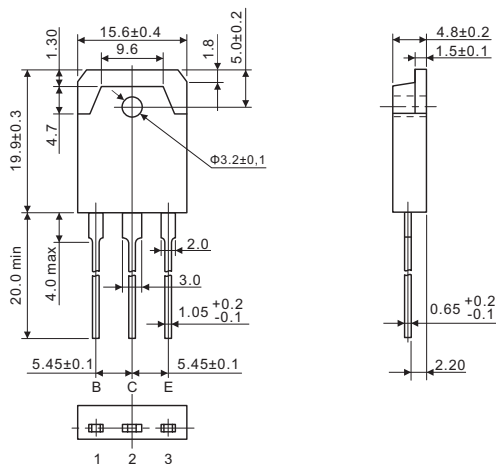

All dimensions in millimeters(inches)

