

# isc N-Channel MOSFET Transistor

# BUK445-60A/B

## DESCRIPTION

- Drain Source Voltage-  
:  $V_{DSS}=60V(\text{Min})$
- Fast Switching Speed
- Minimum Lot-to-Lot variations for robust device performance and reliable operation

## APPLICATIONS

- Designed for Switched Mode Power Supplies (SMPS), motor control, welding, And in general purpose switching resistance application

## ABSOLUTE MAXIMUM RATINGS( $T_a=25^\circ\text{C}$ )

SYMBOL	ARAMETER	VALUE	UNIT
$V_{DSS}$	Drain-Source Voltage ( $V_{GS}=0$ )	60	V
$V_{GS}$	Gate-Source Voltage	$\pm 30$	V
$I_D$	Drain Current-continuous @ $TC=25^\circ\text{C}$	BUK445-60A	21
		BUK445-60B	20
$P_{tot}$	Total Dissipation@ $TC=25^\circ\text{C}$	30	W
$T_j$	Max. Operating Junction Temperature	150	$^\circ\text{C}$
$T_{stg}$	Storage Temperature Range	150	$^\circ\text{C}$

## THERMAL CHARACTERISTICS

SYMBOL	PARAMETER	MAX	UNIT
$R_{th\ j-c}$	Thermal Resistance, Junction to Case	4.17	$^\circ\text{C}/\text{W}$
$R_{th\ j-a}$	Thermal Resistance, Junction to Ambient	55	$^\circ\text{C}/\text{W}$

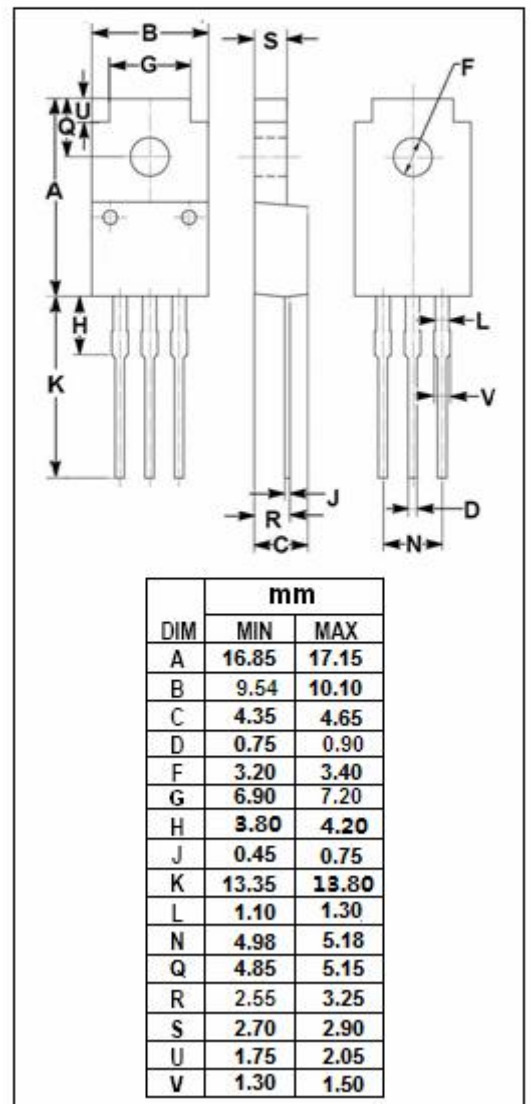
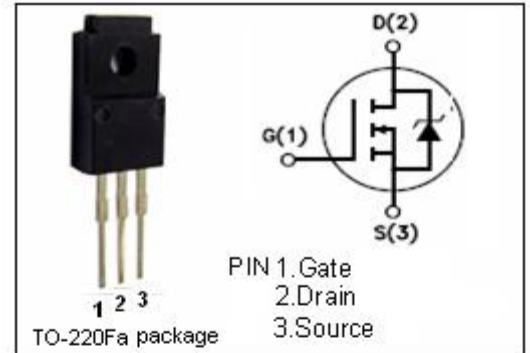

## isc N-Channel Mosfet Transistor

## BUK445-60A/B

• ELECTRICAL CHARACTERISTICS (T<sub>c</sub>=25°C)

SYMBOL	PARAMETER	CONDITIONS	MIN	TYP	MAX	UNIT
V <sub>(BR)DSS</sub>	Drain-Source Breakdown Voltage	V <sub>GS</sub> =0; I <sub>D</sub> = 0.25mA	60			V
V <sub>GS(th)</sub>	Gate Threshold Voltage	V <sub>DS</sub> =V <sub>GS</sub> ; I <sub>D</sub> =1mA	2.1		4.0	V
R <sub>DS(on)</sub>	Drain-Source On-stage Resistance	V <sub>GS</sub> =10V; I <sub>D</sub> =20A	BUK445-60A		0.038	Ω
			BUK445-60B		0.045	Ω
I <sub>GSS</sub>	Gate Source Leakage Current	V <sub>GS</sub> = ±30V; V <sub>DS</sub> = 0			±100	nA
I <sub>DSS</sub>	Zero Gate Voltage Drain Current	V <sub>DS</sub> =60V; V <sub>GS</sub> = 0			10	uA
V <sub>SD</sub>	Diode Forward Voltage	I <sub>F</sub> =21A; V <sub>GS</sub> =0			1.8	V
G <sub>fs</sub>	Forward Transconductance	V <sub>DS</sub> = 25V; I <sub>D</sub> = 20A	8			S
t <sub>r</sub>	Rise time	V <sub>GS</sub> =10V; I <sub>D</sub> =3A; R <sub>GS</sub> =50 Ω		60	90	ns
t <sub>on</sub>	Turn-on time			25	40	ns
t <sub>f</sub>	Fall time			100	130	ns
t <sub>off</sub>	Turn-off time			125	160	ns

**NOTICE:**

ISC reserves the rights to make changes of the content herein the datasheet at any time without notification. The information contained herein is presented only as a guide for the applications of our products.

ISC products are intended for usage in general electronic equipment. The products are not designed for use in equipment which require specialized quality and/or reliability, or in equipment which could have applications in hazardous environments, aerospace industry, or medical field. Please contact us if you intend our products to be used in these special applications.

ISC makes no warranty or guarantee regarding the suitability of its products for any particular purpose, nor does ISC assume any liability arising from the application or use of any products, and specifically disclaims any and all liability, including without limitation special, consequential or incidental damages.