

isc N-Channel MOSFET Transistor
BUK455-100A/B
DESCRIPTION

- Drain Source Voltage-
: $V_{DSS}=100V(\text{Min})$
- LOW $R_{DS(\text{ON})}$
- Fast Switching Speed
- Minimum Lot-to-Lot variations for robust device performance and reliable operation

APPLICATIONS

- Designed for Switched Mode Power Supplies (SMPS), motor control, welding, and in general purpose switching resistance application

ABSOLUTE MAXIMUM RATINGS($T_a=25^\circ\text{C}$)

| SYMBOL | PARAMETER | VALUE | UNIT |
|-----------|--|-------------|------------------|
| V_{DSS} | Drain-Source Voltage ($V_{GS}=0$) | 100 | V |
| V_{GS} | Gate-Source Voltage | ± 30 | V |
| I_D | Drain Current-continuous @ $TC=25^\circ\text{C}$ | BUK455-100A | 26 |
| | | BUK455-100B | 23 |
| P_{tot} | Total Dissipation @ $TC=25^\circ\text{C}$ | 125 | W |
| T_j | Max. Operating Junction Temperature | 175 | $^\circ\text{C}$ |
| T_{stg} | Storage Temperature Range | 175 | $^\circ\text{C}$ |

THERMAL CHARACTERISTICS

| SYMBOL | PARAMETER | MAX | UNIT |
|---------------|---|-----|---------------------------|
| $R_{th\ j-c}$ | Thermal Resistance, Junction to Case | 1.2 | $^\circ\text{C}/\text{W}$ |
| $R_{th\ j-a}$ | Thermal Resistance, Junction to Ambient | 60 | $^\circ\text{C}/\text{W}$ |

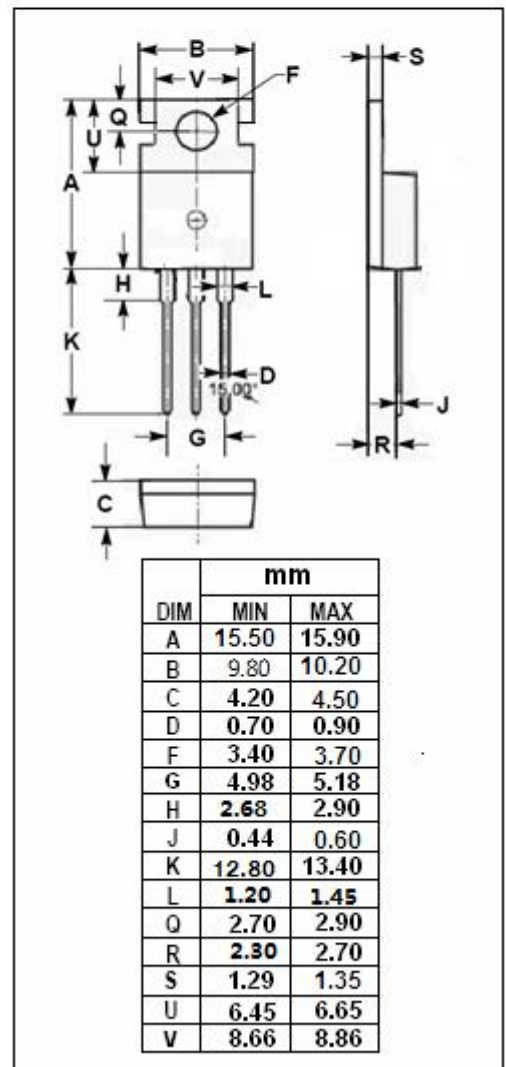
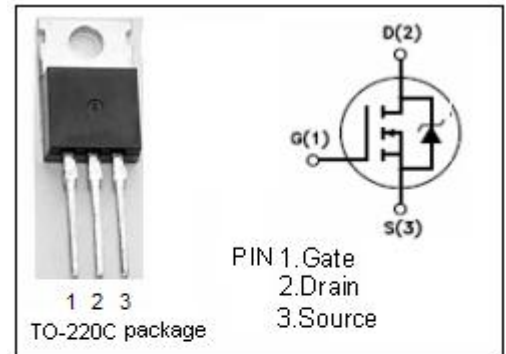

isc N-Channel Mosfet Transistor
BUK455-100A/B
• ELECTRICAL CHARACTERISTICS (T_c=25°C)

| SYMBOL | PARAMETER | CONDITIONS | MIN | TYP | MAX | UNIT |
|----------------------|----------------------------------|---|-------------|-----|------|------|
| V _{(BR)DSS} | Drain-Source Breakdown Voltage | V _{GS} =0; I _D = 0.25mA | 100 | | | V |
| V _{GS(th)} | Gate Threshold Voltage | V _{DS} =V _{GS} ; I _D =1mA | 2.1 | | 4.0 | V |
| R _{DS(on)} | Drain-Source On-stage Resistance | V _{GS} =10V; I _D =13A | BUK455-100A | | 0.08 | Ω |
| | | | BUK455-100B | | 0.1 | Ω |
| I _{GSS} | Gate Source Leakage Current | V _{GS} = ±30V; V _{DS} = 0 | | | ±100 | nA |
| I _{DSS} | Zero Gate Voltage Drain Current | V _{DS} =100V; V _{GS} = 0 | | | 10 | uA |
| V _{SD} | Diode Forward Voltage | I _F =26A; V _{GS} =0 | | | 1.7 | V |
| G _{fs} | Forward Transconductance | V _{DS} = 25V; I _D = 13A | 7.0 | | | S |
| t _r | Rise time | V _{GS} =10V; I _D =3A; R _{GS} =50 Ω | | 25 | 40 | ns |
| t _{on} | Turn-on time | | | 15 | 30 | ns |
| t _f | Fall time | | | 50 | 80 | ns |
| t _{off} | Turn-off time | | | 100 | 160 | ns |

NOTICE:

ISC reserves the rights to make changes of the content herein the datasheet at any time without notification. The information contained herein is presented only as a guide for the applications of our products.

ISC products are intended for usage in general electronic equipment. The products are not designed for use in equipment which require specialized quality and/or reliability, or in equipment which could have applications in hazardous environments, aerospace industry, or medical field. Please contact us if you intend our products to be used in these special applications.

ISC makes no warranty or guarantee regarding the suitability of its products for any particular purpose, nor does ISC assume any liability arising from the application or use of any products, and specifically disclaims any and all liability, including without limitation special, consequential or incidental damages.