



BUT232V

NPN TRANSISTOR POWER MODULE

- HIGH CURRENT POWER BIPOLAR MODULE
- VERY LOW R_{th} JUNCTION CASE
- SPECIFIED ACCIDENTAL OVERLOAD AREAS
- FULLY INSULATED PACKAGE (U.L. COMPLIANT) FOR EASY MOUNTING
- LOW INTERNAL PARASITIC INDUCTANCE

INDUSTRIAL APPLICATIONS:

- MOTOR CONTROL
- SMPS & UPS
- DC/DC & DC/AC CONVERTERS

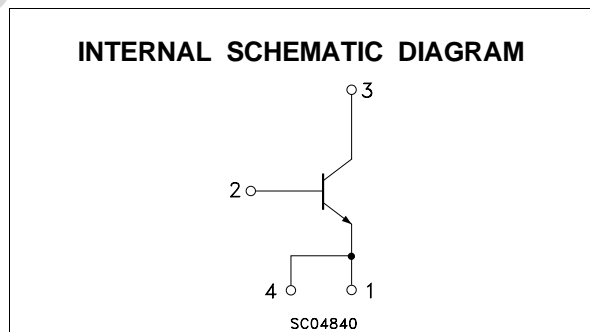
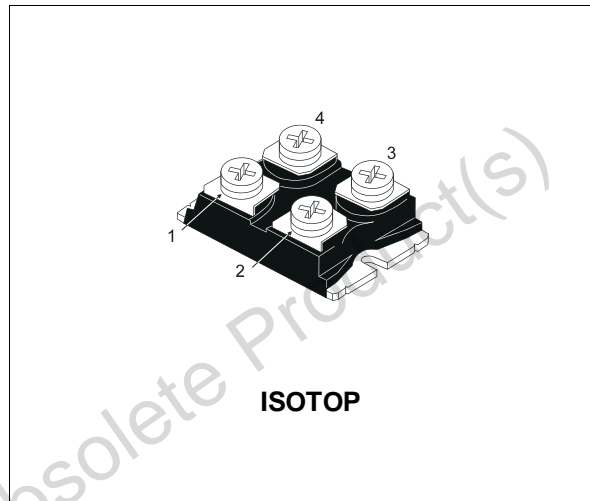

ABSOLUTE MAXIMUM RATINGS

Symbol	Parameter	Value	Unit
V_{CEV}	Collector-Emitter Voltage ($V_{BE} = -5$ V)	400	V
$V_{CEO(sus)}$	Collector-Emitter Voltage ($I_B = 0$)	300	V
V_{EBO}	Emitter-Base Voltage ($I_C = 0$)	7	V
I_C	Collector Current	140	A
I_{CM}	Collector Peak Current ($t_p = 10$ ms)	210	A
I_B	Base Current	28	A
I_{BM}	Base Peak Current ($t_p = 10$ ms)	42	A
P_{tot}	Total Dissipation at $T_c = 25$ °C	300	W
V_{isol}	Insulation Withstand Voltage (RMS) from All Four Terminals to External Heatsink	2500	
T_{stg}	Storage Temperature	-55 to 150	°C
T_j	Max. Operating Junction Temperature	150	°C

BUT232V

THERMAL DATA

$R_{thj-case}$	Thermal Resistance Junction-case	Max	0.41	$^{\circ}\text{C}/\text{W}$
R_{thc-h}	Thermal Resistance Case-heatsink With Conductive Grease Applied	Max	0.05	$^{\circ}\text{C}/\text{W}$

ELECTRICAL CHARACTERISTICS ($T_{case} = 25^{\circ}\text{C}$ unless otherwise specified)

Symbol	Parameter	Test Conditions	Min.	Typ.	Max.	Unit
I_{CER}	Collector Cut-off Current ($R_{BE} = 5 \Omega$)	$V_{CE} = V_{CEV}$ $V_{CE} = V_{CEV}$ $T_c = 100^{\circ}\text{C}$			1 5	mA mA
I_{CEV}	Collector Cut-off Current ($V_{BE} = -1.5$)	$V_{CE} = V_{CEV}$ $V_{CE} = V_{CEV}$ $T_c = 100^{\circ}\text{C}$			1 4	mA mA
I_{EBO}	Emitter Cut-off Current ($I_C = 0$)	$V_{EB} = 5 \text{ V}$			1	mA
$V_{CEO(sus)}^*$	Collector-Emitter Sustaining Voltage ($I_B = 0$)	$I_C = 0.2 \text{ A}$ $L = 25 \text{ mH}$ $V_{clamp} = 300$	300			V
h_{FE}^*	DC Current Gain	$I_C = 70 \text{ A}$ $V_{CE} = 5 \text{ V}$		17		
$V_{CE(sat)}^*$	Collector-Emitter Saturation Voltage	$I_C = 35 \text{ A}$ $I_B = 1.75 \text{ A}$ $I_C = 35 \text{ A}$ $I_B = 1.75 \text{ A}$ $T_c = 100^{\circ}\text{C}$ $I_C = 70 \text{ A}$ $I_B = 7 \text{ A}$ $I_C = 70 \text{ A}$ $I_B = 7 \text{ A}$ $T_c = 100^{\circ}\text{C}$		0.5 0.7 0.5 0.9	1.9 1.9	V V V V
$V_{BE(sat)}^*$	Base-Emitter Saturation Voltage	$I_C = 70 \text{ A}$ $I_B = 7 \text{ A}$ $I_C = 70 \text{ A}$ $I_B = 7 \text{ A}$ $T_c = 100^{\circ}\text{C}$		1.1 1	1.3	V V
di_c/dt	Rate of Rise of On-state Collector	$V_{CC} = 300 \text{ V}$ $R_C = 0$ $t_p = 3 \mu\text{s}$ $I_{B1} = 10 \text{ A}$ $T_c = 100^{\circ}\text{C}$	120	190		A/ μs
$V_{CE(3 \mu\text{s})}$	Collector-Emitter Dynamic Voltage	$V_{CC} = 200 \text{ V}$ $R_C = 3.25 \Omega$ $I_{B1} = 6.4 \text{ A}$ $T_c = 100^{\circ}\text{C}$		2.5	4	V
$V_{CE(5 \mu\text{s})}$	Collector-Emitter Dynamic Voltage	$V_{CC} = 200 \text{ V}$ $R_C = 3.25 \Omega$ $I_{B1} = 6.4 \text{ A}$ $T_c = 100^{\circ}\text{C}$		1.4	2.5	V
t_s	Storage Time	$I_C = 70 \text{ A}$ $V_{CC} = 250 \text{ V}$		3	5	μs
t_f	Fall Time	$V_{BB} = -5 \text{ V}$ $R_{BB} = 0.6 \Omega$		0.25	0.4	μs
t_c	Cross-over Time	$V_{clamp} = 300 \text{ V}$ $I_{B1} = 7 \text{ A}$ $L = 0.3 \text{ mH}$ $T_c = 100^{\circ}\text{C}$		0.6	0.9	μs
V_{CEW}	Maximum Collector Emitter Voltage Without Snubber	$I_{C\text{Woff}} = 105 \text{ A}$ $I_{B1} = 7 \text{ A}$ $V_{BB} = -5 \text{ V}$ $V_{CC} = 50 \text{ V}$ $L = 42 \mu\text{H}$ $R_{BB} = 0.6 \Omega$ $T_c = 125^{\circ}\text{C}$	300			V

* Pulsed: Pulse duration = 300 μs , duty cycle 1.5 %

Safe Operating Area

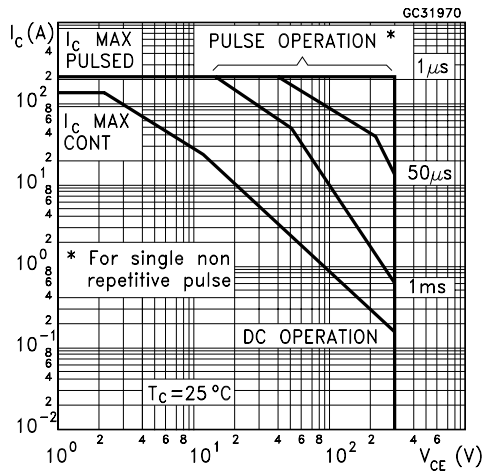

Thermal Impedance

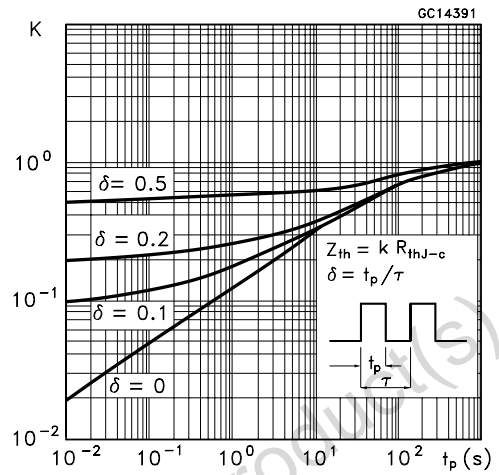

Derating Curve

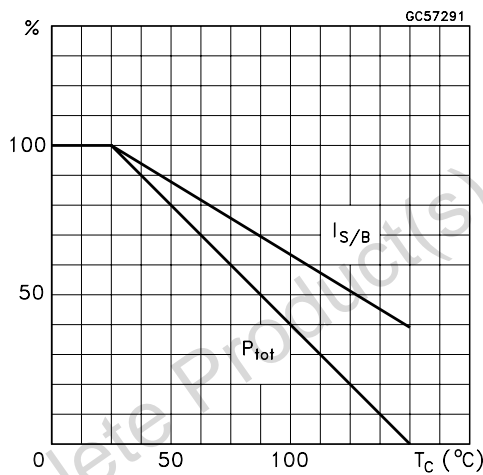

Collector Emitter Voltage Versus Base Emitter Resistance

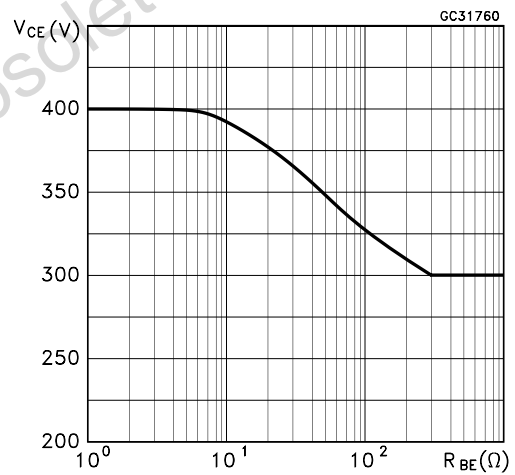

Collector Emitter Saturation Voltage

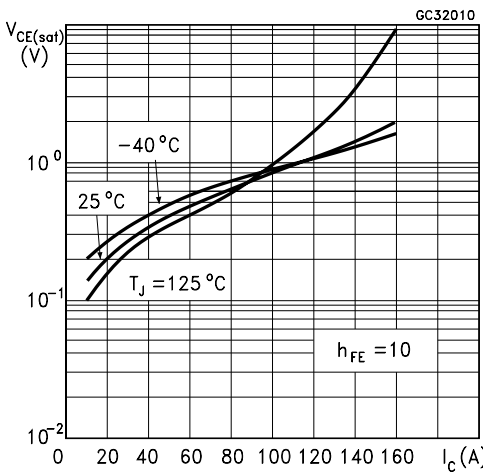

Base-Emitter Saturation Voltage

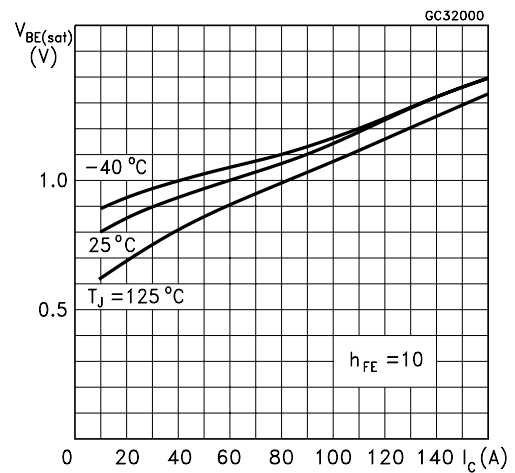

Reverse Biased SOA

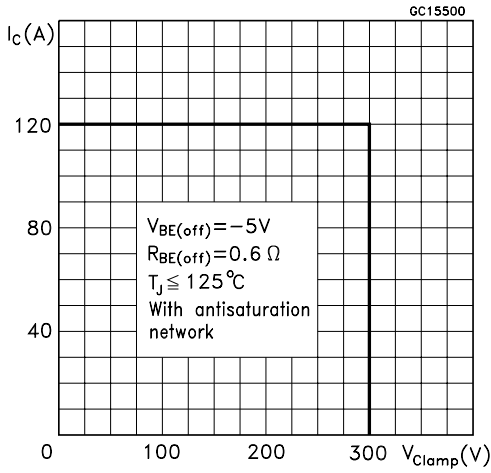

Forward Biased SOA

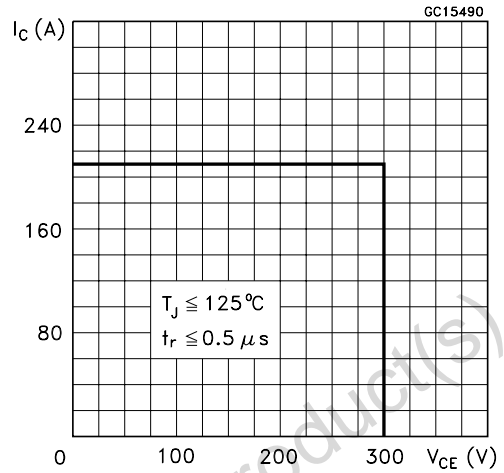

Reverse Biased AOA

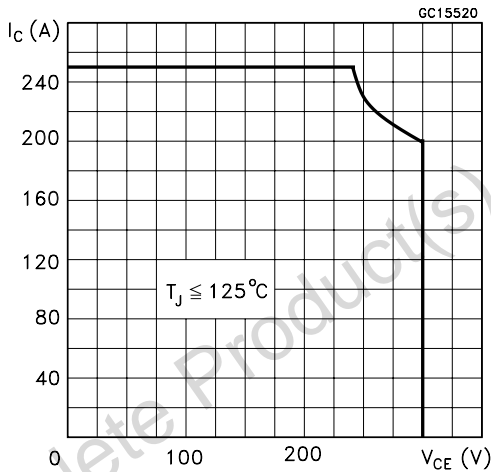

Forward Biased AOA

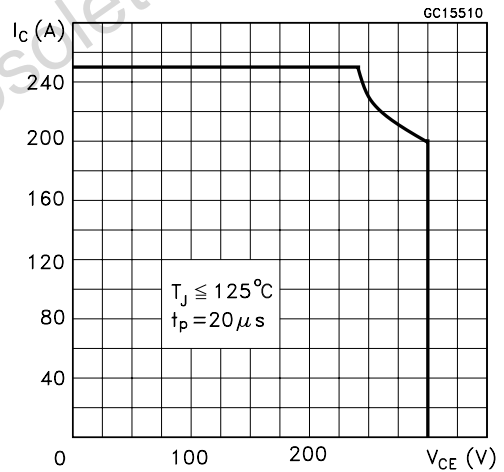

Switching Times Inductive Load

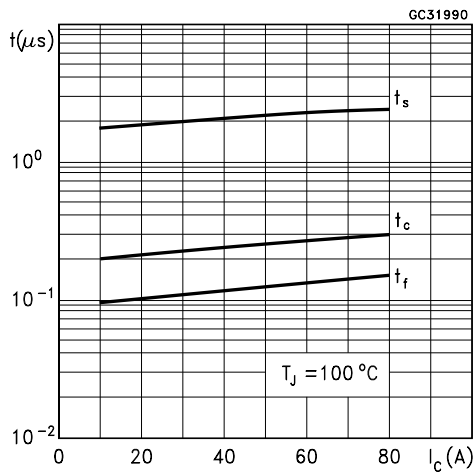

Switching Times Inductive Load Versus Temperature

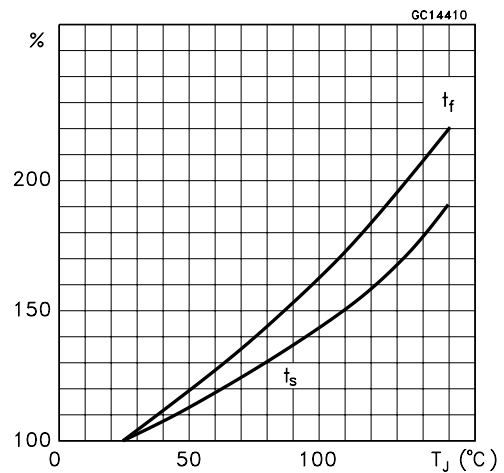

Dc Current Gain

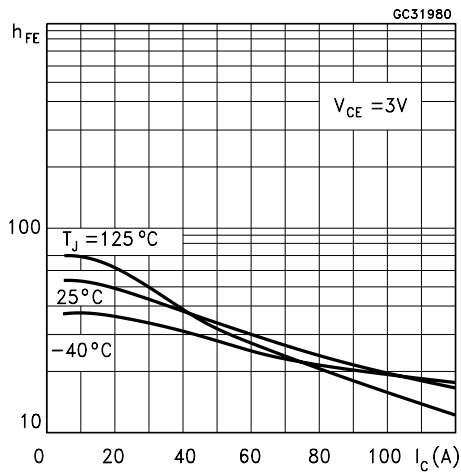

Turn-on Switching Test Circuit

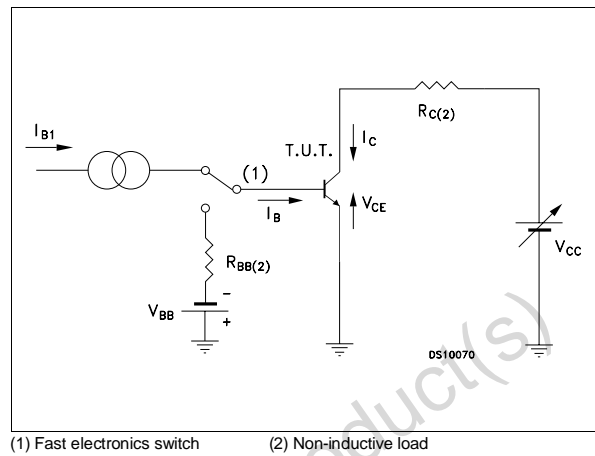

Turn-on Switching Waveforms

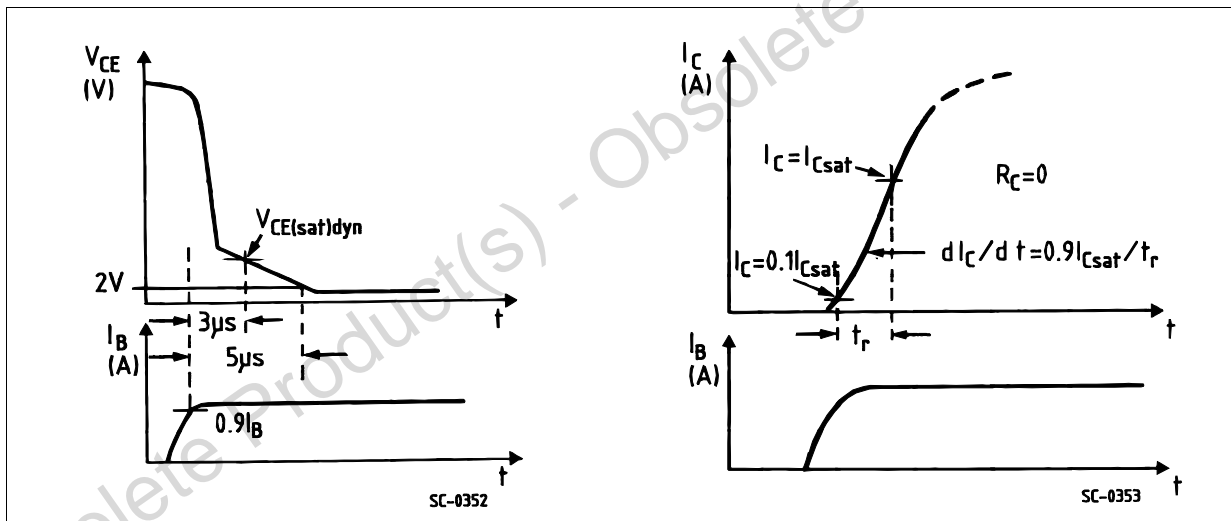

Turn-off Switching Test Circuit

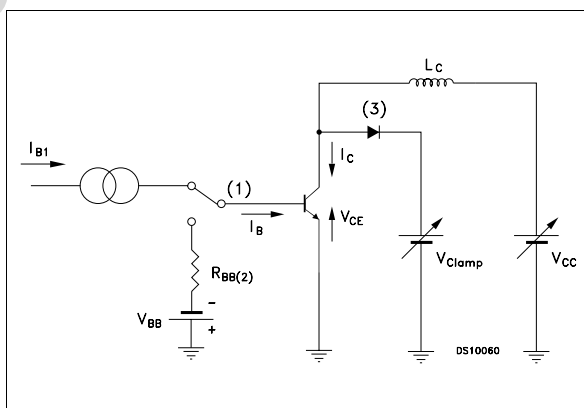

Turn-off Switching Waveforms

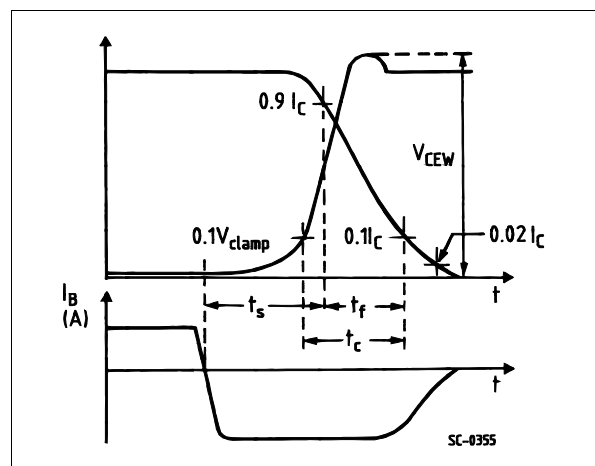

ISOTOP MECHANICAL DATA

DIM.	mm			inch		
	MIN.	TYP.	MAX.	MIN.	TYP.	MAX.
A	11.8		12.2	0.465		0.480
A1	8.9		9.1	0.350		0.358
B	7.8		8.2	0.307		0.322
C	0.75		0.85	0.029		0.033
C2	1.95		2.05	0.076		0.080
D	37.8		38.2	1.488		1.503
D1	31.5		31.7	1.240		1.248
E	25.15		25.5	0.990		1.003
E1	23.85		24.15	0.938		0.950
E2		24.8			0.976	
G	14.9		15.1	0.586		0.594
G1	12.6		12.8	0.496		0.503
G2	3.5		4.3	0.137		1.169
F	4.1		4.3	0.161		0.169
F1	4.6		5	0.181		0.196
P	4		4.3	0.157		0.169
P1	4		4.4	0.157		0.173
S	30.1		30.3	1.185		1.193

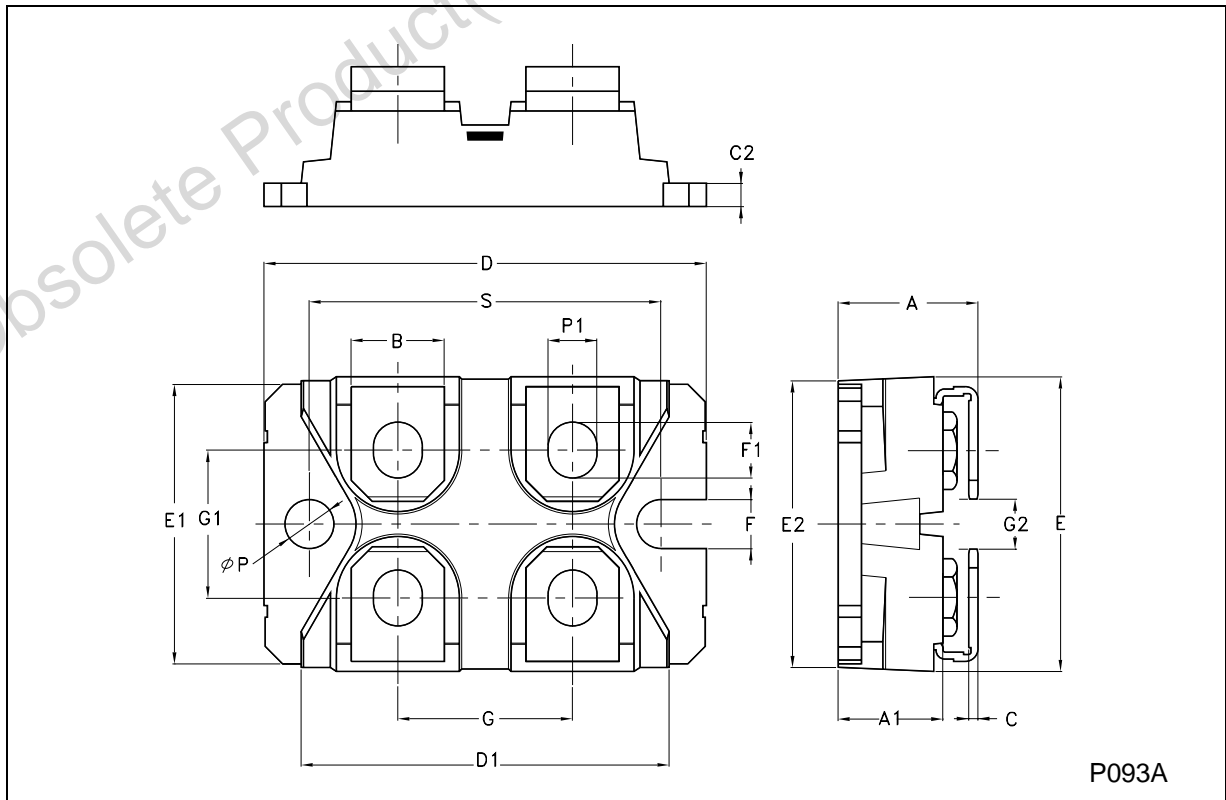

Obsolete Product(s) - Obsolete Product(s)

Information furnished is believed to be accurate and reliable. However, STMicroelectronics assumes no responsibility for the consequences of use of such information nor for any infringement of patents or other rights of third parties which may result from its use. No license is granted by implication or otherwise under any patent or patent rights of STMicroelectronics. Specification mentioned in this publication are subject to change without notice. This publication supersedes and replaces all information previously supplied. STMicroelectronics products are not authorized for use as critical components in life support devices or systems without express written approval of STMicroelectronics.

The ST logo is a trademark of STMicroelectronics

© 2003 STMicroelectronics – Printed in Italy – All Rights Reserved

STMicroelectronics GROUP OF COMPANIES

Australia - Brazil - Canada - China - Finland - France - Germany - Hong Kong - India - Israel - Italy - Japan - Malaysia - Malta - Morocco - Singapore - Spain - Sweden - Switzerland - United Kingdom - United States.

<http://www.st.com>