

## Silicon NPN Power Transistors

## BUV27A

## DESCRIPTION

- With TO-220C package
- Low collector saturation voltage
- Fast switching speed

## APPLICATIONS

- For use in high frequency and efficiency converters, switching regulators and motor control

## PINNING

PIN	DESCRIPTION
1	Base
2	Collector; connected to mounting base
3	Emitter

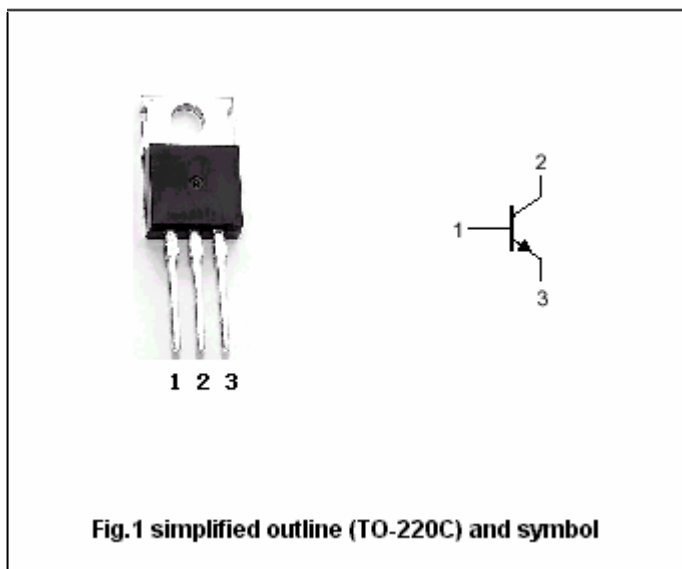
Absolute maximum ratings (T<sub>c</sub>=25 °C)

SYMBOL	PARAMETER	CONDITIONS	VALUE	UNIT
V <sub>CBO</sub>	Collector-base voltage	Open emitter	300	V
V <sub>CEO</sub>	Collector-emitter voltage	Open base	150	V
V <sub>EBO</sub>	Emitter-base voltage	Open collector	7	V
I <sub>C</sub>	Collector current (DC)		12	A
I <sub>CM</sub>	Collector current (peak)		20	A
I <sub>B</sub>	Base current		4	A
I <sub>BM</sub>	Base current (peak)		6	A
P <sub>tot</sub>	Total power dissipation	T <sub>c</sub> =25 °C	85	W
T <sub>j</sub>	Max. operating junction temperature		175	°C
T <sub>stg</sub>	Storage temperature		-65~175	°C

## THERMAL CHARACTERISTICS

SYMBOL	PARAMETER	MAX	UNIT
R <sub>th j-case</sub>	Thermal resistance junction case	1.76	°C/W

## Silicon NPN Power Transistors

## BUV27A

## CHARACTERISTICS

T<sub>j</sub>=25 °C unless otherwise specified

www.datasheet4u.com

SYMBOL	PARAMETER	CONDITIONS	MIN	TYP.	MAX	UNIT
V <sub>CEQ(SUS)</sub>	Collector-emitter sustaining voltage	I <sub>C</sub> =0.2 A ; I <sub>B</sub> =0; L=25mH	150			V
V <sub>(BR)EBO</sub>	Emitter-base breakdown voltage	I <sub>E</sub> =50mA; I <sub>C</sub> =0	7		30	V
V <sub>CEsat-1</sub>	Collector-emitter saturation voltage	I <sub>C</sub> =4A ; I <sub>B</sub> =0.4 A			0.7	V
V <sub>CEsat-2</sub>	Collector-emitter saturation voltage	I <sub>C</sub> =7A; I <sub>B</sub> =0.7A			1.5	V
V <sub>BEsat</sub>	Base-emitter saturation voltage	I <sub>C</sub> =7A; I <sub>B</sub> =0.7A			2	V
I <sub>CEX</sub>	Collector cut-off current	V <sub>CE</sub> =300V; V <sub>BE</sub> = -1.5 V T <sub>C</sub> =125 °C			1	mA
I <sub>EBO</sub>	Emitter cut-off current	V <sub>EB</sub> =5V; I <sub>C</sub> =0			1	mA

Silicon NPN Power Transistors

BUV27A

PACKAGE OUTLINE

www.datasheet4u.com

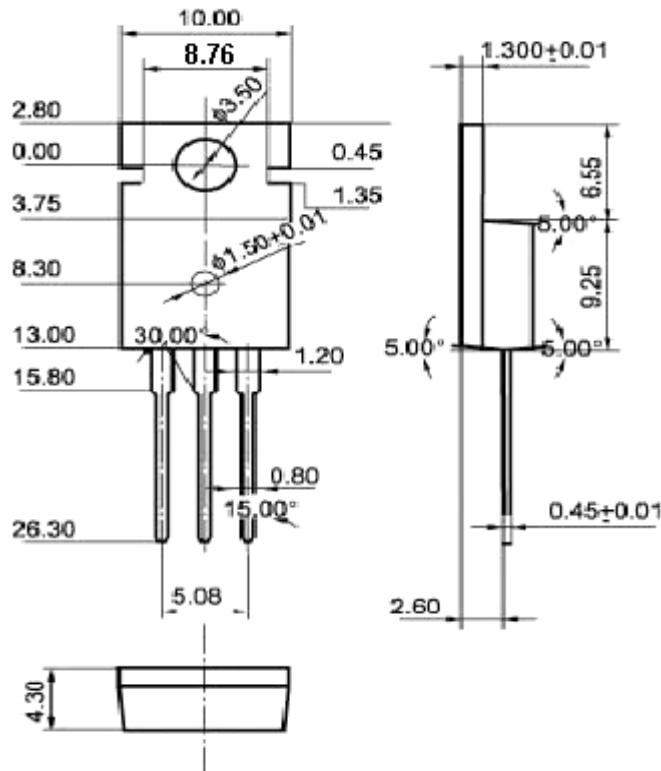

Fig.2 Outline dimensions (unindicated tolerance: 0.1mm)