

The data should be read in conjunction with the Power Triode Preamble.

### ABRIDGED DATA

Three RF power triodes intended for transmitter and industrial heating service. They differ mainly in the method of anode cooling and anode dissipation.

Anode cooling:	
BR1161 (CV9343)	forced-air
BW1161	water; separate water jacket
BY1161	vapour; separate boiler unit
Anode dissipation:	
BR1161	35 kW max
BW1161	50 kW max
BY1161	60 kW max
Anode voltage	
	14 kV max
Frequency for full ratings	
	10 MHz max
Frequency at reduced ratings	
	30 MHz max
Output power (class C unmodulated conditions):	
BR1161	100 kW
BW1161, BY1161	120 kW

### GENERAL

#### Electrical

Filament (see note 1)	thoriated tungsten
Filament voltage (see note 2)	11 V
Filament current	155 A
Surge filament current (peak) (see note 3)	300 A max
Filament cold resistance	9.2 mΩ
Peak usable cathode current	60 A
Amplification factor	
( $V_a = 9.0$ kV, $I_a = 3.0$ A)	90
Mutual conductance	
( $V_a = 10.0$ kV, $I_a = 2.5$ A)	60 mA/V
Perveance	4.0 mA/V <sup>3/2</sup>
Inter-electrode capacitances:	
grid to anode	75 pF
grid to filament	130 pF
anode to filament	1.0 pF

#### Mechanical

Overall dimensions	see outline drawings
Net weight:	
BR1161	40.0 kg approx
BW1161	13.6 kg approx
BY1161	24.0 kg approx
Mounting position	vertical, filament leads up

#### Accessories

Water jacket for BW1161	BW4215
Sealing ring (supplied with BW1161)	MA254
Boiler units for BY1161:	
external condenser required	BY4059
integral condenser	BY4093
Sealing ring (supplied with BY1161)	MA245
Thermal fuse (2 supplied with BY1161)	MA85D

### COOLING

#### Anode

BR1161 air cooling requirements are shown on page 7. The required air flow should be delivered through the radiator immediately before and during the application of any voltages.

The anode of the BW1161 must be fitted into a water jacket for cooling, the recommended jacket being type BW4215. Minimum water cooling requirements are shown on page 8. The rates of flow given apply to tubes with clean anode surfaces; higher values should be used where possible.

The BY1161 is vapour cooled and may be operated either in boiler unit BY4059 or BY4093. In BY4093, the steam generated at the anode is condensed by means of an internal water cooled condenser. The steam produced in BY4059 is led away by suitably insulated tubing for condensation at some convenient point external to the boiler unit.

Two thermal fuses (MA85D) are provided with each BY1161 to give protection against anode overheating; only one fuse at a time need be used. Alternative positions for mounting the thermal fuse are provided by four threaded holes equispaced round the anode ring. The fuse should be screwed into the desired position and connected by a non-conducting cord to a suitable switching device; a tension of about 450 g should be applied to the fuse via a cord. If the temperature exceeds a safe limit, the fuse core is pulled outwards; this should actuate the switching device and remove all electrical supplies from the tube. Replacement fuses can be supplied to order.

#### Filament and Grid Seals

The temperature of the filament and grid seals must not exceed 170 °C. A flow of air of 1.0 m<sup>3</sup>/min directed into the filament header via a 25 mm approx diameter nozzle before and during the application of any voltages is usually adequate for limiting the temperature of these seals. The air flow should be maintained for at least 10 minutes after switching off the filament supply to the tube.

#### Anode Seal and Envelope

The anode seal and envelope temperatures must not exceed 170 °C.

**ANODE MODULATED RF POWER AMPLIFIER (Class C telephony, carrier conditions per tube for use with a maximum modulation factor of 1.0)**

**MAXIMUM RATINGS (Absolute values)**

Anode voltage:			
operating frequency 10 MHz . . . . .	11		kV
operating frequency 30 MHz . . . . .	10		kV
Anode current (mean) (see note 4) . . . . .	15		A
Anode dissipation (see note 5):			
BR1161 . . . . .	24		kW
BW1161 . . . . .	33		kW
BY1161 . . . . .	40		kW
Grid voltage (negative value) . . . . .	750		V
Grid dissipation . . . . .	1.5		kW

**TYPICAL OPERATING CONDITIONS**

Frequency . . . . .	10	30	MHz
Anode voltage . . . . .	11	10	kV
Grid voltage (fixed) . . . . .	-150	-150	V
Grid resistor . . . . .	250	250	$\Omega$
Peak RF grid drive voltage . . . . .	1200	1200	V
Anode current . . . . .	6.0	6.0	A
Grid current (approx) . . . . .	2.3	2.3	A
Anode dissipation . . . . .	11	10	kW
Grid dissipation (approx) . . . . .	1.1	1.1	kW
Driving power (approx) . . . . .	2.8	2.8	kW
Output power . . . . .	55	50	kW
Efficiency . . . . .	83	83	%

**RF POWER AMPLIFIER AND OSCILLATOR (Class C telegraphy, key-down conditions, one tube)**

**MAXIMUM RATINGS (Absolute values)**

Anode voltage:			
operating frequency 10 MHz . . . . .	14		kV
operating frequency 30 MHz . . . . .	12		kV
Anode current (mean) (see note 4) . . . . .	15		A
Anode dissipation:			
BR1161 . . . . .	35		kW
BW1161 . . . . .	50		kW
BY1161 . . . . .	60		kW
Grid voltage (negative value) . . . . .	750		V
Grid dissipation . . . . .	1.5		kW

**TYPICAL OPERATING CONDITIONS**

**(For amplifier)**

	BY1161	BR1161	
Anode voltage . . . . .	14	12	kV
Grid voltage . . . . .	-350	-300	V
Peak RF grid drive voltage . . . . .	910	820	V
Anode current . . . . .	11.3	11.0	A
Grid current (approx) . . . . .	2.4	2.4	A
Anode dissipation . . . . .	38	32	kW
Grid dissipation (approx) . . . . .	1.36	1.28	kW
Driving power (approx) . . . . .	2.2	2.0	kW
Output power . . . . .	120	100	kW
Efficiency . . . . .	76	76	%

**RF OSCILLATOR FOR INDUSTRIAL SERVICE (Class C conditions, one tube)**

**MAXIMUM RATINGS (Absolute values)**

Anode voltage:			
operating frequency 10 MHz . . . . .	14		kV
operating frequency 30 MHz . . . . .	12		kV
Anode current (mean) (see note 4) . . . . .	15		A
Anode dissipation:			
BR1161 . . . . .	35		kW
BW1161 . . . . .	50		kW
BY1161 . . . . .	60		kW
Grid voltage (negative value) . . . . .	750		V
Grid dissipation . . . . .	1.5		kW

**TYPICAL OPERATING CONDITIONS**

Anode voltage (see note 6) . . . . .	9.5	11.4	kV
Grid voltage . . . . .	-240	-280	V
from grid resistor . . . . .	220	235	$\Omega$
Peak RF grid drive voltage . . . . .	640	780	V
Anode current . . . . .	8.0	8.7	A
Grid current (approx) . . . . .	1.1	1.2	A
Anode dissipation . . . . .	25	30	kW
Grid dissipation (approx) . . . . .	400	600	W
Driving power (approx) . . . . .	700	935	W
Output power . . . . .	55	75	kW
Efficiency . . . . .	70	72	%
Load resistance . . . . .	850	880	$\Omega$

**RANGE OF CHARACTERISTICS FOR EQUIPMENT DESIGN**

	Min	Max	
Filament current at filament voltage 11 V . . . . .	145	165	A
Amplification factor			
( $V_a = 9.0$ kV, $I_a = 3.0$ A) . . . . .	75	110	
Mutual conductance			
( $V_a = 10.0$ kV, $I_a = 2.5$ A) . . . . .	45	-	mA/V
Grid voltage (negative value)			
( $V_a = 10.0$ kV, $I_a = 0.1$ A) . . . . .	-	160	V
Grid current			
( $V_a = 2.5$ kV, $I_a = 44.0$ A) . . . . .	-	17	A
Grid voltage			
( $V_a = 2.5$ kV, $I_a = 44.0$ A) . . . . .	-	620	V
Grid current			
( $V_a = 0.8$ kV, $I_a = 40.0$ A) . . . . .	-	27	A
Grid voltage			
( $V_a = 0.8$ kV, $I_a = 40.0$ A) . . . . .	-	670	V

## NOTES

1. Connections to the filament are normally made via the flexible leads fitted to the tube. Should RF connections be required, these should be made with flexible conductors to the terminals below the filament leads.
2. The tube must normally be operated at the stated filament voltage. When the operating grid dissipation is less than 400 W the filament voltage should be increased to 11.5 V. Fluctuation in filament voltage must not exceed  $\pm 5\%$ .
3. The filament current must not exceed 300 A, even momentarily, at any time.
4. It is recommended that a resistor of at least 25  $\Omega$  should be connected in series with the anode to limit the surge current in case of flashover (unless adequate protection is already provided by other circuit elements).
5. This corresponds to 35 kW, 50 kW and 60 kW anode dissipation respectively at 100% sine wave modulation.
6. The anode voltage from a 3-phase half-wave rectifier without filter, measured with a moving coil meter.

## HEALTH AND SAFETY HAZARDS

e2v technologies electronic devices are safe to handle and operate, provided that the precautions stated are observed. e2v technologies does not accept responsibility for damage or injury resulting from the use of electronic devices it produces. Equipment manufacturers and users must ensure that adequate precautions are taken. Appropriate warning labels and notices must be provided on equipments incorporating e2v technologies devices and in operating manuals.



### High Voltage

Equipment must be designed so that personnel cannot come into contact with high voltage circuits. All high voltage circuits and terminals must be enclosed and fail-safe interlock switches must be fitted to disconnect the primary power supply and discharge all high voltage capacitors and other stored energy before allowing access. Interlock switches must not be bypassed to allow operation with access doors open.



### RF Radiation

Personnel must not be exposed to excessive RF radiation. A properly designed equipment cabinet with good RF electrical connection between panels will normally provide sufficient protection.



### X-Ray Radiation

This device, when operating at voltages above 5 kV, produces progressively more dangerous X-rays as the voltage is increased; the radiation varies greatly during life. The device envelope provides only limited protection and further shielding may be required. A metal equipment cabinet with overlapping joints will usually provide sufficient shielding, but if there is any doubt an expert in this field should perform an X-ray survey of the equipment.



### Implosion

This tube stores potential energy by virtue of its vacuum. The energy level is low, but there is some hazard from flying fragments if the tube is dropped or subjected to violent impact. The tube must be stored and transported in its approved pack.

## References

1. BS 3192. Specification for safety requirements for radio (including television) transmitting apparatus.
2. TEPAC Publication no. 181. Recommended practice for measurement of X-radiation from power tubes.

# TYPICAL ANODE CHARACTERISTICS

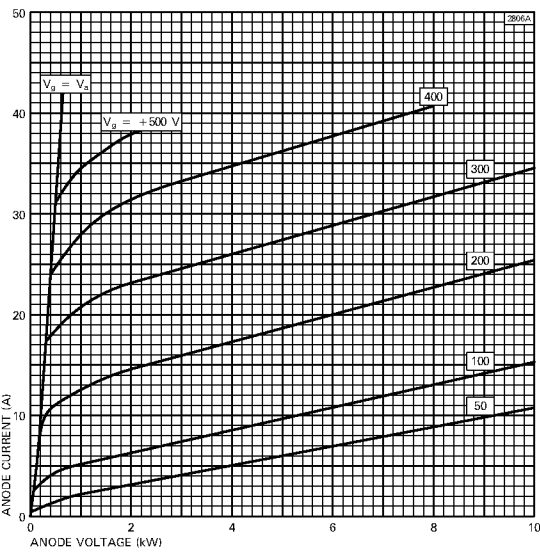

# TYPICAL STRAPPED CHARACTERISTICS

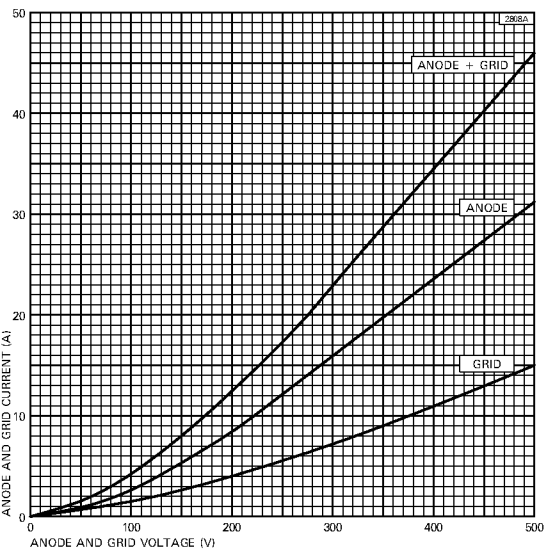

# TYPICAL GRID CHARACTERISTICS

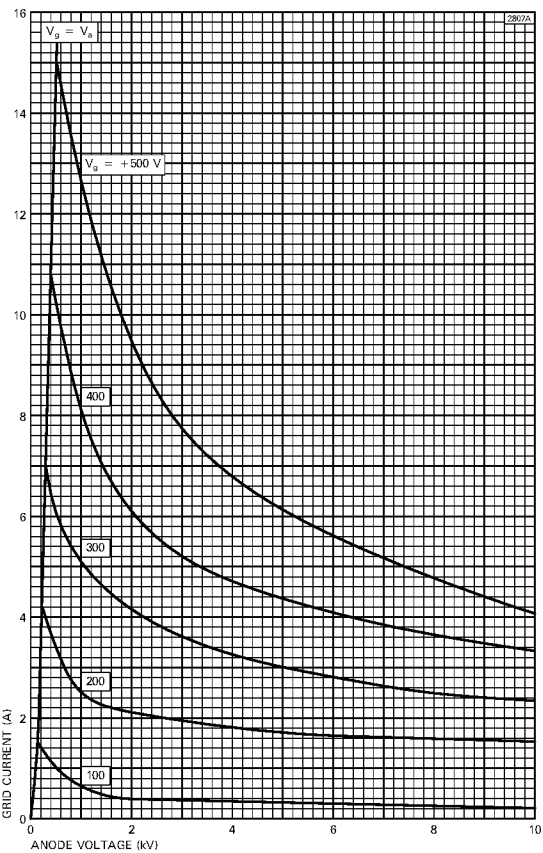

# TYPICAL CONSTANT CURRENT CHARACTERISTICS

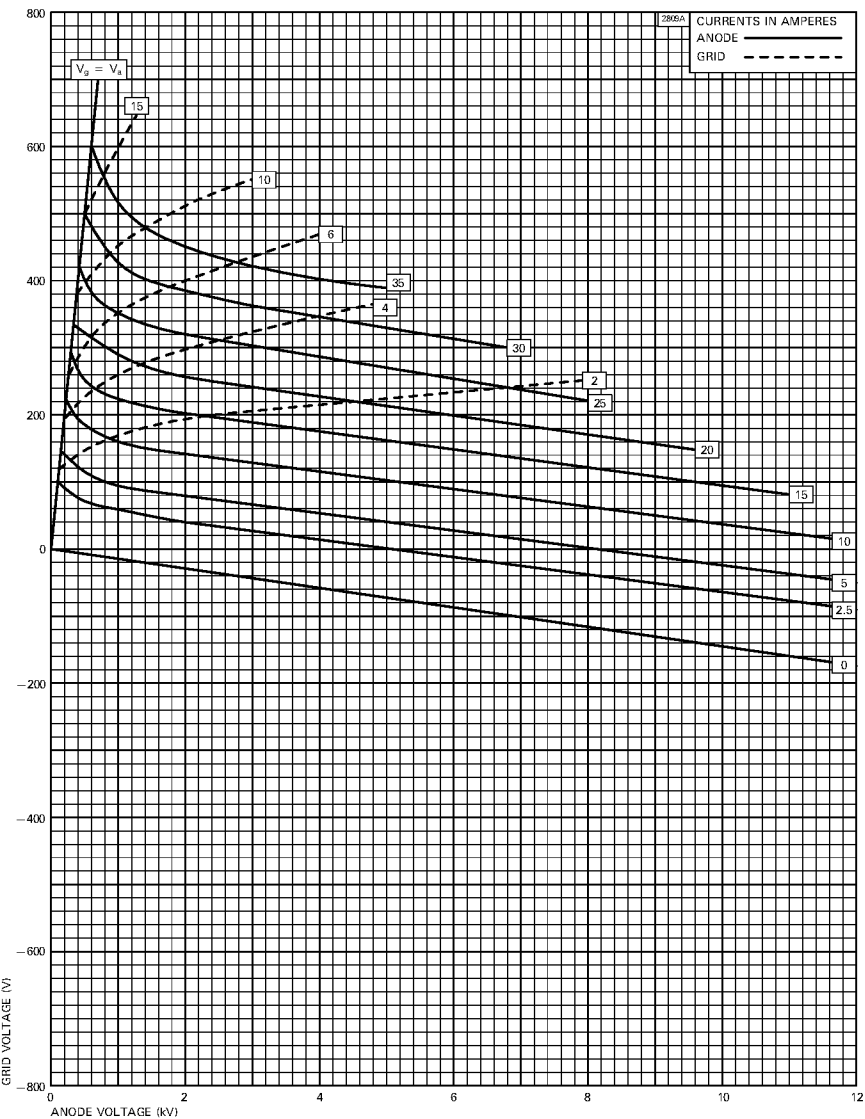

# AIR COOLING REQUIREMENTS FOR BR1161

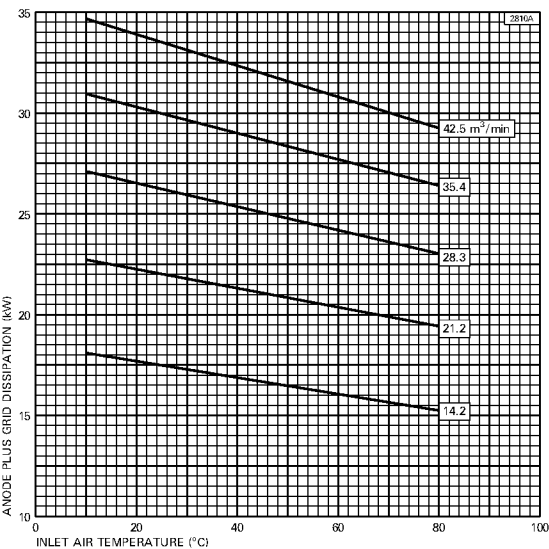

## TYPICAL AIR FLOW CHARACTERISTIC FOR BR1161

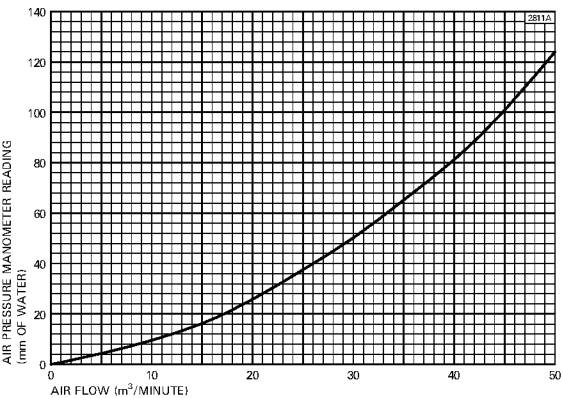

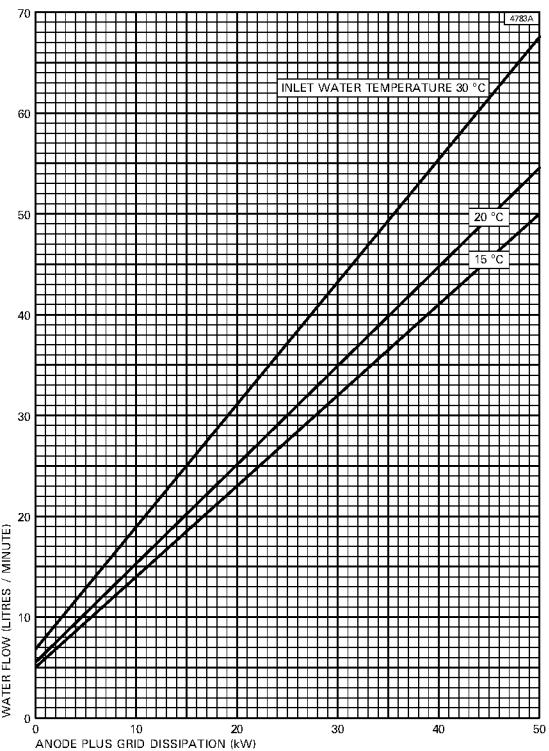



OUTLINE FOR BR1161 (All dimensions without limits are nominal)

2804A

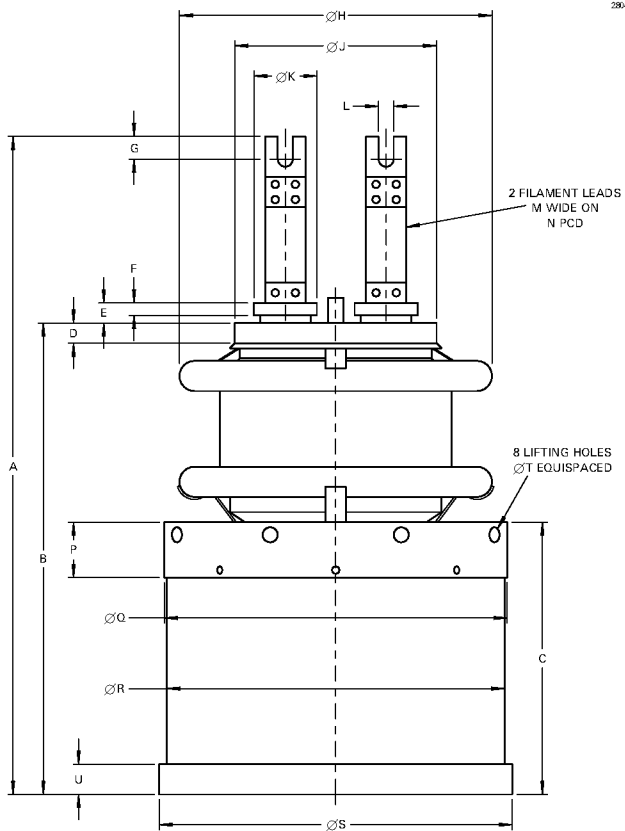

Ref	Millimetres
A	526.0 max
B	375.0 $\pm$ 1.0
C	217.0 + 2.5 - 1.0
D	17.0
E	19.0
F	12.0
G	19.0
H	251.5 max
J	164.5 $\pm$ 0.5
K	50.0 $\pm$ 0.4
L	11.0
M	35.0
N	80.0
P	45.0
Q	274.0 + 1.0 - 0.5
R	270.0
S	282.0 $\pm$ 1.0
T	12.0
U	25.0

OUTLINE FOR BW1161 (All dimensions without limits are nominal)

4867A

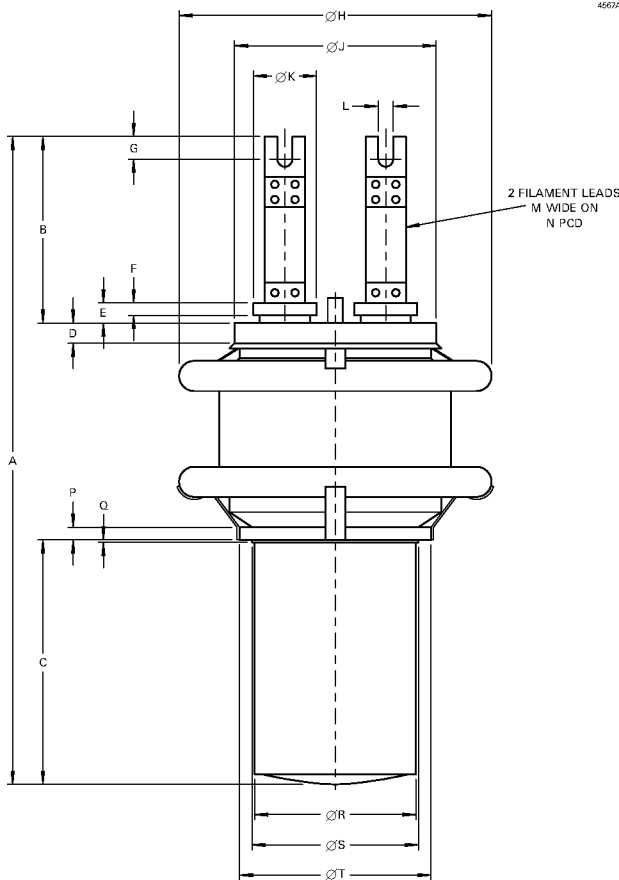

Ref	Millimetres
A	520.0 max
B	150.0
C	195.0
D	17.0
E	19.0
F	12.0
G	19.0
H	251.5 max
J	164.5 ± 0.5
K	50.0 ± 0.4
L	11.0
M	35.0
N	80.0
P	12.7
Q	2.0
R	127.0
S	130.0
T	155.0

# OUTLINE FOR BY1161 (All dimensions without limits are nominal)

2866A

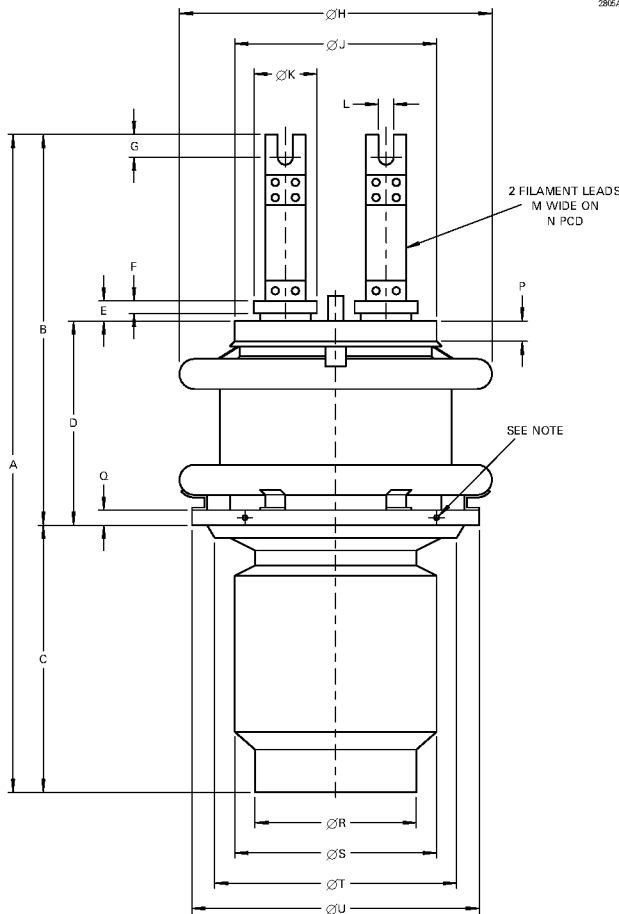

Ref	Millimetres
A	525.0 max
B	314.0 max
C	211.0 max
D	162.0 ± 2.0
E	19.0
F	12.0
G	19.0
H	251.5 max
J	164.5 ± 0.5
K	50.0 ± 0.4
L	11.0
M	35.0
N	80.0
P	17.0
Q	10.0 ± 0.2
R	130.0
S	158.0 ± 1.0
T	192.0 ± 0.2
U	225.0 ± 0.2

## Note

4 holes threaded 4 BA  
 equispaced to accept  
 thermal fuse.