

## BW7386

### Accuracy Constant Current LED Driver

#### Description

The BW7386 is a highly-integrated, low startup current, current mode, and fixed switching frequency PWM controller. These functions enable the LED driver to easily meet the accuracy average LED current requirements. The integrated functions also include the LED open protection, and internal over temperature protection. The COMP pin controls the duty by connected an RC compensation network to ground and forming the closed loop feedback control. To protect the external power MOSFET from being damaged by supply over voltage, the BW7386 OUT pin voltage is clamped to about 17V. The BW7386 improves the performance and reduces the cost of the LED driver. It is a 6-pin SOT-26 package.

#### Features

- Accuracy Constant Current
- Low BOM Cost
- Current Mode/Fixed Frequency Control
- Gate Output Voltage Clamp
- LED Open Protection(OVP)
- Over Current Protection (OCP)
- 300mA Driving Capability for OUT Pin
- RoHS compliant package



**RoHS**  
COMPLIANT

#### Packing & Order Information

3,000/Reel

#### Pin Configurations (Top View)

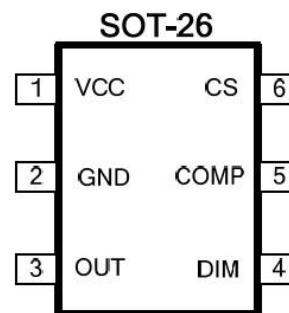

#### Applications

- E26/27, T5/T8 LED Lamp
- Others LED Lighting Applications

#### PIN DESCRIPTIONS

Pin Name	Pin Description
VCC	Power supply pin
GND	Ground pin
OUT	The output driver for driving the external MOSFET
DIM	Dimming Control Pin by Input a DC Voltage
COMP	Feedback compensation network
CS	Current sense pin, connect to sense the MOSFET current

# BW7386

## Accuracy Constant Current LED Driver

### TYPICAL APPLICATION CIRCUITS

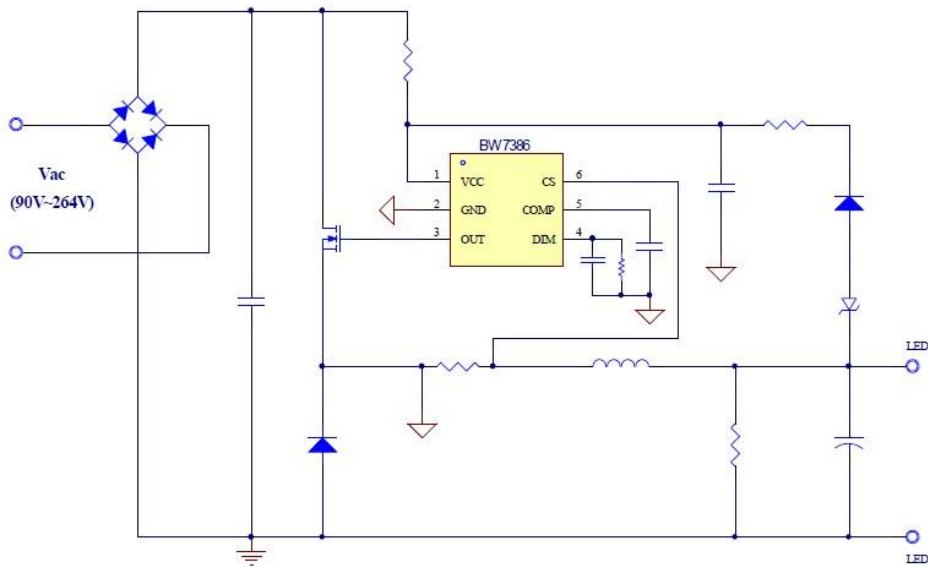

#### ABSOLUTE MAXIMUM RATINGS (Note 1)

Parameter	Symbol	Range	Unit
Power supply pin	$V_{DD}$	30	V
DIM voltage to GND	$V_{DIM}$	-0.3 to 7	V
CS voltage to GND	$V_{CS}$	-0.3 to 7	V
OUT voltage to GND	$V_{OUT}$	15	V
Maximum junction temperature	$T_J$	150	°C
Storage temperature rang	$T_{STG}$	-65 to +150	°C
Lead temperature (Soldering 5 sec)	$T_{LEAD}$	260	°C
Power dissipation @ $T_A=25^{\circ}C$	$P_D$	300	Mw
Thermal resistance junction to ambient (Note 2)	$\theta_{JA}$	333	°C/W
Thermal Resistance	$\theta_{JC}$	106.6	°C/W
ESD rating, Human body mode (Note 3)	$V_{ESD}$	2	kV
ESD rating, machine mode (Note 3)	$V_{ESD}$	200	V

# BW7386

## Accuracy Constant Current LED Driver

### RECOMMENDED OPERATING CONDITIONS (Note 4)

Parameter	Symbol	Operation Conditions	Unit
Supply voltage	V <sub>DD</sub>	26	V
Operating junction temperature range	T <sub>J</sub>	150	°C
Operating ambient temperature range	TOPA	-20 to +85	°C

Note 1: Stresses listed as the above “Absolute Maximum Ratings” may cause permanent damage to the device. These are for stress ratings. Functional operation of the device at these or any other conditions beyond those indicated in the operational sections of the specifications is not implied. Exposure to absolute maximum rating conditions for extended periods may remain possibility to affect device reliability.

Note 2: Thermal Resistance is specified with the component mounted on a low effective thermal conductivity test board in free air at TA=25°C.

Note 3: Devices are ESD sensitive. Handling precaution recommended.

Note 4: The device is not guaranteed to function outside its operating conditions.

### BLOCK DIAGRAM

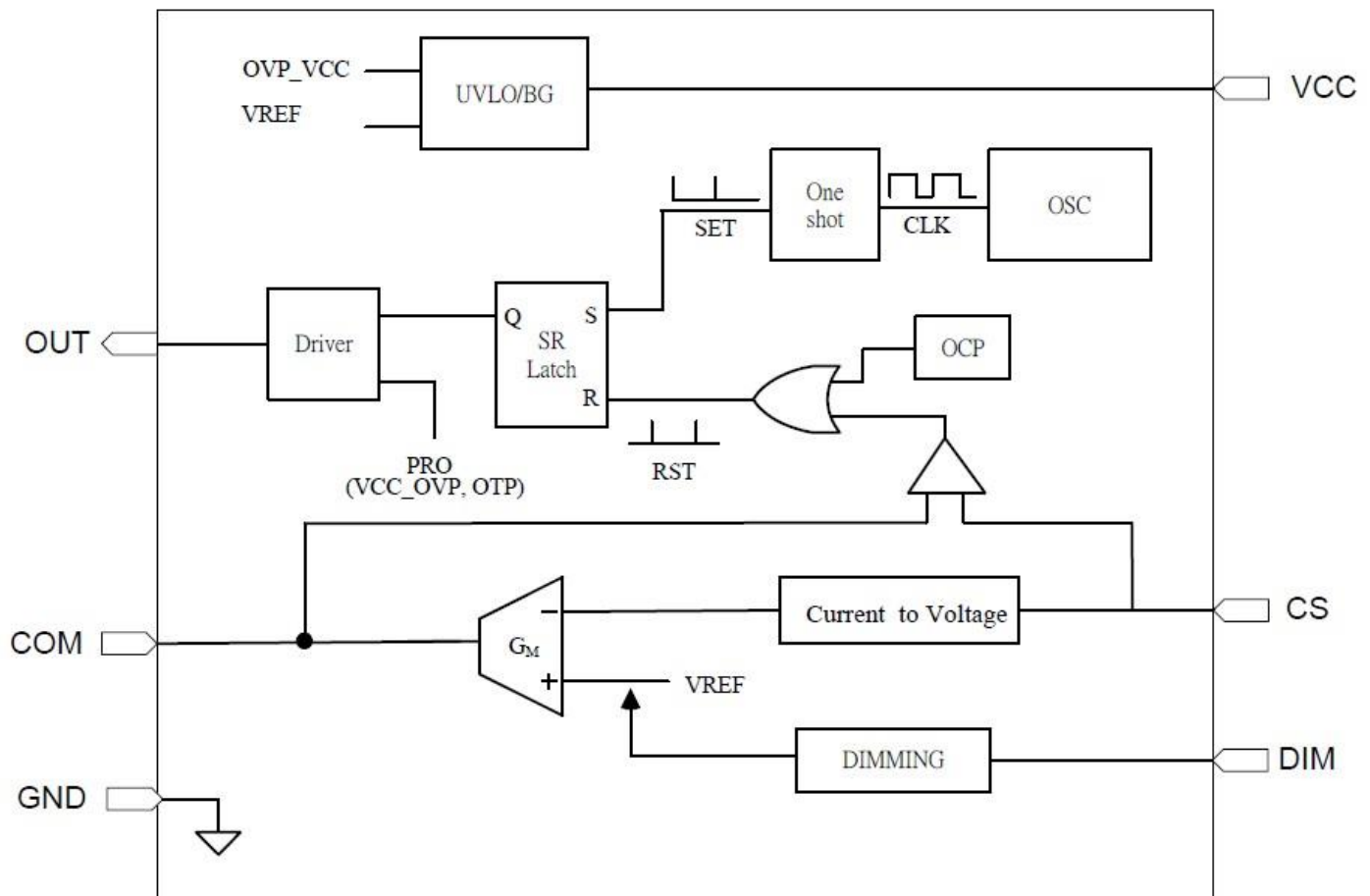

Block Diagram

## BW7386

### Accuracy Constant Current LED Driver

ELECTRICAL CHARACTERISTICS VCC=15V, TA= 25°C, unless otherwise specified.

#### SUPPLY VOLTAGE

Parameter	Symbol	Conditions	Min	Typ.	Max.	Units
Startup Current	V <sub>DD(ST)</sub>	VCC=UVLO on -1V		8		uA
Operating Current	V <sub>COMP</sub>	With 1nF load on OUT pin		1.5	2.5	mA
Operating Current	I <sub>OPA</sub>	With 1nF load on OUT pin Protection Tripped (OCP, OVP,SCP,OTP)		1.2	1.8	mA
UVLO(off)			7	8	8	V
UVLO(on)			17	18	19	V
OVP Level on VCC Pin	OVP		26	28	30	V

#### VOLTAGE FEEDBACK

Parameter	Symbol	Conditions	Min	Typ.	Max.	Units
Feedback Reference Voltage	V <sub>FB</sub>		0.194	0.2	0.206	V
Tran-Conductance				120		uS
Output Sink Current	I <sub>o-sink</sub>			12		uA
Output Source Current	I <sub>o-source</sub>			12		uA

#### CURRENT SENSING

Parameter	Symbol	Conditions	Min	Typ.	Max.	Units
Input Over Voltage Protection	F <sub>OSC</sub>			0.8		V
Open Loop Voltage, CS Pin Open				5		V
Leading-Edge Blanking Time				410		nS
Delay to Output				100		nS

#### SWITCHING FREQUENCY

Parameter	Symbol	Conditions	Min	Typ.	Max.	KHz
Switching Frequency			42	45	48	%
Maximum Duty			90			%
Frequency Jitter Range				+/-6		%
Temp. Stability		-40°C ~125°C			6	%
Voltage Stability		VCC=11V~25V			1	%

#### GATE DRIVER OUTPUT

Parameter	Symbol	Conditions	Min	Typ.	Max.	Units
Rising Time		Load Capacitance = 1000pF		160		nS
Falling Time		Load Capacitance = 1000pF		80		nS
VGATE-Clamp		VCC=25V 17 19 V		17	19	V

## BW7386

### Accuracy Constant Current LED Driver

#### DIM INPUT SECTION

Parameter	Symbol	Conditions	Min	Typ.	Max.	Units
Saturation Threshold Voltage			3.0			V
Linear Dimming Range			0.6		3.0	V
Current Source			270	300	330	uA

#### Thermal Section

Parameter	Symbol	Conditions	Min	Typ.	Max.	Units
Thermal Shutdown	TSD			150		°C

## BW7386

### Accuracy Constant Current LED Driver

#### APPLICATION INFORMATION

##### Start-up Current

The typical start-up current is around 8uA. Very low start-up current allows the PWM controller to increase the value of start-up resistor and then reduce the power dissipation on it.

##### UVLO(Under Voltage Lockout)

A hysteresis UVLO comparator is implemented in BW7386 then the turn-on and turn-off thresholds level are fixed at 18V and 8V respectively. This hysteresis shown in Fig.1 ensures that the start-up capacitor will be adequate to supply the chip during start-up. For quickly startup the LED driver, the start-up resistor should be matched with the startup capacitor. Due to the low UVLO on level, so the turn-on delay time will also never greater than the general PWM IC.

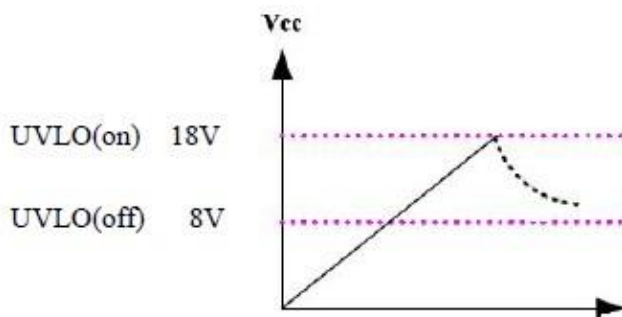

Fig. 1

##### Oscillator

The maximum duty-cycle of internal oscillator is up to 90% for driving high LED voltage string. The frequency of the oscillator is fixed to 45KHZ by internal setting.

##### LEB(Leading-Edge Blanking)

Each time the power MOSFET is switched on, a turn-on spike will inevitably occur at the sense resistor. To avoid fault trigger, a 410ns leading-edge blanking time is built in. Conventional RC filtering can therefore be omitted. During this blanking period, the current-limit comparator is disabled and can not switch off the gate driver.

##### OCP(Over Current Protection)

The BW7386 has an over current protection function on CS pin. An internal circuit detects the current level, when the current is larger than a threshold level, the gate output will keep on low level. Then VCC decreases below UVLO off level, the controller resets again.

##### OVP (Over Voltage Protection) on VCC

To prevent the LED driver from being damaged, the BW7386 is implemented an OVP function on VCC. When the VCC voltage is higher than the OVP threshold voltage 28V, the output gate driver circuit will be shut down immediately to stop the switching of power MOSFET. The VCC pin OVP function is an auto recovery type protection (latch off type optional). If the OVP condition happens, the pulses will be stopped and never recovery unless the VCC pin voltage is down to the UVLO off level. The BW7386 is working in an auto-recovery mode as shown in Fig. 2.

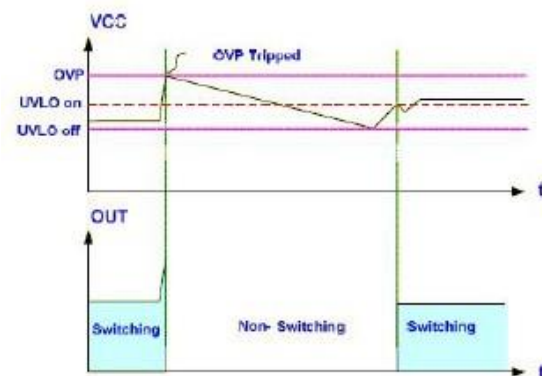

Fig. 2

##### Gate Clamp/Soft Driving

Driver is clamped to 17V by an internal clamping circuit. Those damages usually come from undesired over-voltage gate signals. Under the conditions listed below, the gate output will turn off immediately to protect the power circuit. The BW7386 also has soft driving function to minimize EMI.

## BW7386

### Accuracy Constant Current LED Driver

#### Disclaimer

ALL PRODUCT, PRODUCT SPECIFICATIONS AND DATA ARE SUBJECT TO CHANGE WITHOUT NOTICE TO IMPROVE RELIABILITY, FUNCTION OR DESIGN OR OTHERWISE.

Bruckewell Technology Inc., its affiliates, agents, and employees, and all persons acting on its or their behalf (collectively, "Bruckewell"), disclaim any and all liability for any errors, inaccuracies or incompleteness contained in any datasheet or in any other disclosure relating to any product.

Bruckewell makes no warranty, representation or guarantee regarding the suitability of the products for any particular purpose or the continuing production of any product. To the maximum extent permitted by applicable law, Bruckewell disclaims

- (i) Any and all liability arising out of the application or use of any product.
- (ii) Any and all liability, including without limitation special, consequential or incidental damages.
- (iii) Any and all implied warranties, including warranties of fitness for particular purpose, non-infringement and merchantability.

Statements regarding the suitability of products for certain types of applications are based on Bruckewell's knowledge of typical requirements that are often placed on Bruckewell products in generic applications. Such statements are not binding statements about the suitability of products for a particular application. It is the customer's responsibility to validate that a particular product with the properties described in the product specification is suitable for use in a particular application. Parameters provided in datasheets and/or specifications may vary in different applications and performance may vary over time.

Product specifications do not expand or otherwise modify Bruckewell's terms and conditions of purchase, including but not limited to the warranty expressed therei