

BW9910/A High Brightness LED Driver

Features

- Efficiency > 90%
- Universal rectified 85V_{AC} to 265V_{AC} input range
- Constant current LED driver
- Applications from a few mA to more than 1.0A
- LED string from one to hundreds of diodes
- PWM low-frequency dimming via PWM_D pin
- Input voltage surge ratings up to 500V
- Internal over temperature protection (OTP)
- 7.5V MOSFET drive – BW9910
- 10V MOSFET drive – BW9910A

Typical Applications

- AC/DC or DC/DC LED Driver applications
- RGB backlighting LED Driver
- Backlighting of flat panel displays
- General purpose constant current source
- Signage and decorative LED lighting
- Buck/Buck-Boost/Boost LED driver
- T8/T9/T10 LED tubes
- E26/E27 LED bulbs

Product Description

The BW9910/BW9910A is a PWM high-efficiency LED driver control IC. It allows efficient operation of high brightness (HB) LEDs from voltage sources ranging from 85V_{AC} up to 265V_{AC}. The BW9910/BW9910A controls an external MOSFET at fixed switching frequency up to 300kHz. The frequency can be programmed using a single resistor. The LED string is driven at constant current rather than constant voltage, thus providing constant light output and enhanced reliability. The output current can be programmed between a few mA and up to more than 1.0A.

The BW9910/BW9910A uses a rugged high voltage junction isolated process that can withstand an input voltage surge of up to 500V. Output current to an LED string can be programmed to any value between zero and its maximum value by applying an external control voltage at the linear dimming control input of the BW9910/BW9910A. The BW9910/BW9910A provides a low-frequency PWM dimming input that can accept an external control signal with a duty ratio of 0%~100% and a frequency of up to a few kHz.

The BW9910A allows wider range of external MOSFET which has lower R_{DS(ON)} (drain-source on resistance) at higher V_{GS}. The BW9910/BW9910A is available in SOP-8 and SO8-EP packages.

Typical Application Circuit

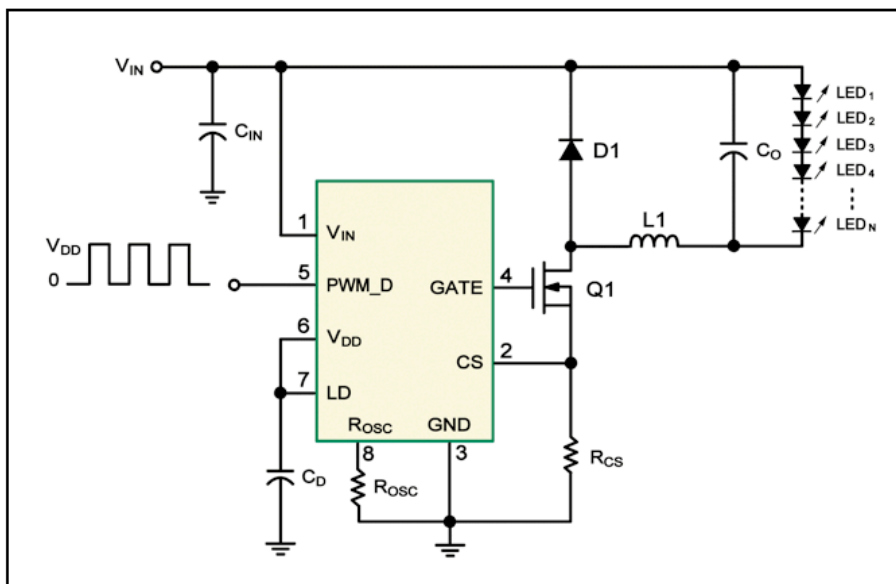



BW9910/A High Brightness LED Driver

Pin Assignments and Ordering Information

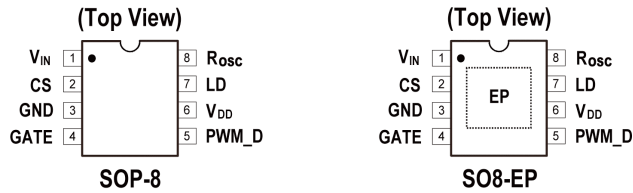

Device	V _{CS} Tolerance	Packaging	Quantity of Tape & Reel
BW9910 MST	±10%	SOP-8	3000
BW9910 MPT	±10%	SO8-EP	3000
BW9910A MST	±10%	SOP-8	3000
BW9910A MPT	±10%	SO8-EP	3000

Pin Descriptions

SOP-8	SO8-EP	Pin Name	Function
1	1	V _{IN}	Input voltage pin. DC input supply voltage.
2	2	CS	Current sensing input pin. Senses LED string current.
3	3	GND	Ground pin. Device ground.
4	4	GATE	Gate driver output pin. Drives the gate of the external MOSFET.
5	5	PWM_D	PWM dimming input pin. Low frequency PWM dimming pin, also enable input. Internal 200kΩ pull-down resistor to GND.
6	6	V _{DD}	Internal/External supply voltage pin. Internally regulated supply voltage. 7.5V nominal for the BW9910 and 10V nominal for the BW9910A. This pin can supply up to 1.0mA for external circuitry. A sufficient storage capacitor is used to provide storage when the rectified AC input is near the zero crossings.
7	7	LD	Linear dimming input pin. Linear dimming by changing the current limit threshold at current sensing comparator.
8	8	R _{OSC}	Oscillator control pin. A resistor connected between this pin and GND sets the PWM frequency.
N/A	EP	EP Pad	Exposed pad. Package bottom. Connect to GND directly underneath the package.



BW9910/A High Brightness LED Driver

Absolute Maximum Ratings ^(Note 1)

Symbol	Parameter	Ratings	Unit
V_{INDC}	DC input supply voltage range, V_{IN} to GND	-0.5 ~ +520	V
V_{CS}	CS input pin voltage range relative to GND	-0.3 ~ +0.45	V
V_{LD}	LD input pin voltage range relative to GND	-0.3 ~ +(V _{DD} + 0.3)	V
V_{PWM_D}	PWM_D input pin voltage range relative to GND	-0.3 ~ +(V _{DD} + 0.3)	V
V_{GATE}	GATE output pin voltage range relative to GND	-0.3 ~ +(V _{DD} + 0.3)	V
	Continuous power dissipation (T _A = +25°C)		
	8 Pin SO (de-rating 6.3mW/°C above +25°C)	0.63	W
	8 Pin SO-EP (de-rating 16mW/°C above +25°C)	1.6	W
T _J	Junction temperature	+150	°C
T _{STG}	Storage temperature range	-65 ~ +150	°C
θ _{JA}	Junction-to-ambient thermal resistance for SOP-8	165	°C/W
θ _{JA(EP)}	Junction-to-ambient thermal resistance for SO8-EP	60	°C/W

Note :

- Exceeding these ratings could cause damage to the device. All voltages are with respect to ground. Currents are positive into, negative out of the specified terminal.

Recommended Operating Conditions

Symbol	Parameter		Min.	Max.	Unit
V_{INDC}	DC input supply voltage range, V_{IN} to GND	BW9910	15	500	V
		BW9910A	20	500	
$V_{EN(LO)}$	PWM_D input pin low voltage range relative to GND		0	1.0	V
$V_{EN(HI)}$	PWM_D input pin high voltage range relative to GND		2.4	V _{DD}	V
T _A	Ambient temperature range for SOP-8 package ^(Note 2)	BW9910 MST	-40	+85	°C
T _{A(EP)}	Ambient temperature range for SO8-EP package ^(Note 2)	BW9910 MPT	-40	+105	°C

Note :

- Maximum ambient temperature range is limited by allowable power dissipation. The exposed pad SO8-EP with its lower thermal impedance allows the variants using this package to extend the allowable maximum ambient temperature range.



BW9910/A High Brightness LED Driver

Electrical Characteristics

(Over recommended operating conditions unless otherwise specified. $T_A = +25^\circ\text{C}$)

Parameter	Symbol	Min.	Typ.	Max.	Unit	Condition
Input DC supply voltage range	V_{INDC}	15		500	V	BW9910
		20		500		BW9910A
Shut down mode supply current	I_{INSD}		0.5	1.0	mA	BW9910
			0.65	1.20		BW9910A
Internally regulated voltage	V_{DD}	7.0	7.5	8.0	V	BW9910
		9.5	10.0	11.0		BW9910A
V_{DD} current available for external circuitry ^(Note 4)	$I_{\text{DD(EXT)}}$			1.0	mA	$V_{\text{IN}} = V_{\text{INDC(MIN)}} \sim 100\text{V}$ (Note 3)
V_{DD} under voltage lockout threshold	V_{UVLO}	6.4	6.7	7.0	V	BW9910
		8.4	9.0	9.6		BW9910A
V_{DD} under voltage lockout hysteresis	ΔV_{UVLO}		500		mV	BW9910
			650			BW9910A
PWM_D pull-down resistance	$R_{\text{PWM_D}}$	150	200	250	k Ω	$V_{\text{PWM_D}} = 5\text{V}$
Current sensing pull in threshold voltage	V_{CS}	225	250	275	mV	Full ambient temperature range (Note 5)
GATE high output voltage	$V_{\text{GATE(HI)}}$	$V_{\text{DD}} - 0.3$		V_{DD}	V	$I_{\text{OUT}} = 10\text{mA}$
GATE low output voltage	$V_{\text{GATE(LO)}}$	0		0.3	V	$I_{\text{OUT}} = -10\text{mA}$
Oscillator frequency	f_{OSC1}	20	26	32	kHz	$R_{\text{OSC}} = 1\text{M}\Omega$
	f_{OSC2}	80	100	120		$R_{\text{OSC}} = 226\text{k}\Omega$
Maximum oscillator PWM duty cycle	$D_{\text{MAX(HF)}}$			100	%	$f_{\text{PWM(HF)}} = 25\text{kHz}$, at GATE, CS tie to GND.
Linear dimming pin voltage range	V_{LD}	0		250	mV	Full ambient temperature range (Note 5), $V_{\text{IN}} = 20\text{V}$
Current sensing blanking interval	t_{BLANK}	160	250	440	ns	$V_{\text{CS}} = 0.5\text{V}$
Delay from CS trip to GATE low	t_{DELAY}			300	ns	$V_{\text{IN}} = 20\text{V}$, $V_{\text{LD}} = 0.15\text{V}$, $V_{\text{CS}} = 0\text{V} \sim 0.22\text{V}$ after t_{BLANK}
GATE output rise time	t_{RISE}		30	50	ns	$C_{\text{GATE}} = 500\text{pF}$
GATE output fall time	t_{FALL}		30	50	ns	$C_{\text{GATE}} = 500\text{pF}$
Thermal shut down	T_{SD}		150		$^\circ\text{C}$	
Thermal shut down hysteresis	ΔT_{SD}		50		$^\circ\text{C}$	

Note :

3. $V_{\text{INDC(MIN)}}$ for the BW9910 is 15V and for the BW9910A it is 20V.

4. Also limited by package power dissipation limit, whichever is lower.

5. Full ambient temperature range for BW9910 MST and BW9910A MST is -40 to $+85^\circ\text{C}$; for BW9910 MPT and BW9910A MPT is -40 to $+105^\circ\text{C}$.



BW9910/A High Brightness LED Driver

Functional Block Diagram

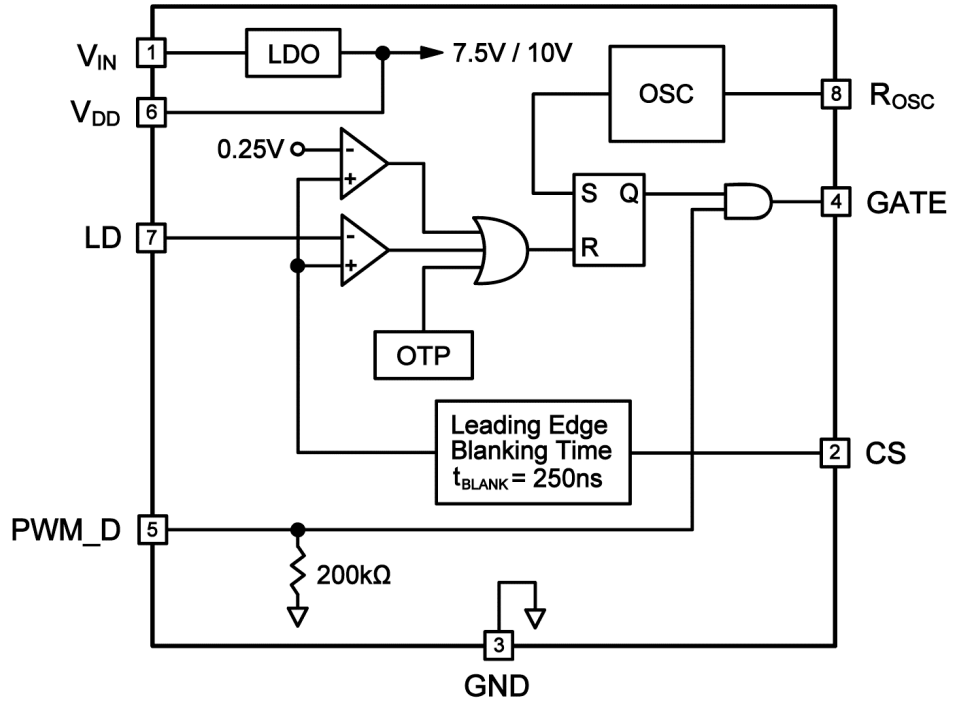



BW9910/A High Brightness LED Driver

Application Information

AC-DC Off-Line Application

The BW9910/BW9910A is a low cost off-line buck or boost converter control IC specifically designed for driving multi-LED strings or arrays. It can be operated from either universal AC line or any DC voltage between 15V and 500V. Optionally, a passive power factor correction circuit can be used in order to pass the AC harmonic limits set by EN61000-3-2 class C for lighting equipment having input power less than 25W. The BW9910/BW9910A can drive up to hundreds of HB LEDs or multiple strings of HB LEDs. The LED arrays can be configured as a series or series/parallel connection. The BW9910/BW9910A regulates constant current that ensures controlled brightness and spectrum of the LEDs, and extends their lifetime, and also allows PWM control of brightness via an enable (PWM_D) pin.

The BW9910/BW9910A can also control brightness of LEDs by programming continuous output current of the LED driver (so-called linear dimming) when a control voltage is applied to the LD pin.

The BW9910/BW9910A is offered in standard 8-pin SOIC and SOIC-EP packages.

The BW9910/BW9910A has a built-in high-voltage linear regulator that powers all internal circuits and can also serve as a bias supply for low voltage and low power external circuitry.

LED Driver Operation

The BW9910/BW9910A can control all basic types of converters, isolated or non-isolated, operating in continuous or discontinuous conduction mode. When the gate signal turns on the external power MOSFET, the LED driver stores the input energy in an inductor or in the primary inductance of a transformer and, depending on the converter type, may partially deliver the energy directly to LEDs. The energy stored in the magnetic component is further delivered to the output during the off-cycle of the power MOSFET producing current through the string of LEDs (Fly-back mode of operation).

When the voltage at the V_{DD} pin exceeds the V_{UVLO} threshold voltage, the gate drive is enabled. The output current is controlled by means of limiting peak current in the external power MOSFET. A current sensing resistor is

connected in series with the source terminal of the MOSFET. The voltage from the sensing resistor is applied to the CS pin of the BW9910/BW9910A. When the voltage at CS pin exceeds a peak current sensing threshold voltage, the gate drive signal terminates, and the power MOSFET turns off. The threshold is internally set to 250mV, or it can be programmed externally by applying voltage to the LD pin. When the soft-start function is required, a capacitor can be connected to the LD pin to allow this voltage to ramp at a desired rate, therefore, assuring that output current of the LED ramps gradually. Additionally, a simple passive power factor correction circuit, consisting of 3 diodes and 2 capacitors, can be added as shown in the typical application circuit diagram of Figure 6.

Supply Current

A current of 1.0mA is needed to start the BW9910/BW9910A. As shown in the block diagram on page 5, this current is internally generated in the BW9910/BW9910A without using bulky startup resistors typically required in the off-line applications. Moreover, in many applications the BW9910/BW9910A can be continuously powered using its internal linear regulator that provides a regulated voltage of 7.5V/10V for all internal circuits.

Setting Lighting Output

When the buck converter topology of Figure 5 is selected, the peak CS voltage is a good representation of the average current in the LED. However, there is a certain error associated with this current sensing method that needs to be accounted for. This error is introduced by the difference between the peak and the average current in the inductor. For example, if the peak-to-peak ripple current in the inductor is 150mA, to get a 500mA LED current, the sensing resistor should be as follows :

$$R_{CS} = \frac{250\text{mV}}{500\text{mA} + 0.5 \times 150\text{mA}} = 0.43\Omega$$

Dimming

Dimming can be accomplished in two ways, separately or combined, depending on the application. Light output of the LED can be controlled either by linear change of its current, or by switching the current on and off while maintaining it constant. The second dimming method

BW9910/A High Brightness LED Driver

(so-called PWM dimming) controls the LED brightness by varying the duty ratio of the output current.

The linear dimming can be implemented by applying a control voltage from 0 to 250mV to the LD pin. This control voltage overrides the internally set 250mV threshold level of the CS pin and programs the output current accordingly. For example, a potentiometer connected between V_{DD} and ground can program the control voltage at the CS pin. Applying a control voltage higher than 250mV will not change the output current setting. When higher current is desired, select a smaller sensing resistor.

The PWM dimming scheme can be implemented by applying an external PWM signal to the PWM_D pin. The PWM signal can be generated by a microcontroller or a pulse generator with a duty cycle proportional to the amount of desired light output. This signal enables and disables the converter modulating the LED current in the PWM fashion. In this mode, LED current can be in one of the two states: zero or the nominal current set by the current sense resistor. It is not possible to use this method to achieve average brightness levels higher than the one set by the current sense threshold level of the BW9910/BW9910A. By using the PWM control method of the BW9910/BW9910A, the light output can be adjusted between zero and 100%. The accuracy of the PWM dimming method is limited only by the minimum gate pulse width, which is a fraction of a percentage of the low frequency duty cycle. PWM dimming of the LED light can be achieved by turning on and off the converter with low frequency 50Hz to 1kHz TTL logic level signal.

Programming Operating Frequency

The operating frequency of the oscillator is programmed between 25kHz and 300kHz using an external resistor connected to the R_{OSC} pin.

Equation :

$$f_{OSC} = \frac{25000}{R_{OSC} + 22} \quad (1)$$

where f_{OSC} unit is kHz. R_{OSC} unit is in k Ω and shall be 820k Ω ~ 1M Ω for the case of $V_{OUT} < 7V$ because it has to satisfy the condition of $t_{ON} > t_{BLANK}$. The efficiency can be improved as well.

Power Factor Correction

When the input power to the LED driver does not exceed 25W, a simple passive power factor correction circuit can be added to the BW9910/BW9910A typical application circuit in Figure 2 in order to pass the AC line harmonic limits of the EN61000-3-2 standard for class C equipment. The typical application circuit diagram shows how this can be done without affecting the rest of the circuit significantly. A simple circuit consisting of 3 diodes and 2 capacitors is added across the rectified AC line input to improve the line current harmonic distortion and to achieve a power factor greater than 0.85.

Inductor Design

The buck circuit is usually selected and it has two operation modes: continuous and discontinuous conduction modes. A buck power stage can be designed to operate in continuous mode for load current above a certain level usually 15% to 30% of full load. Usually, the input voltage range, the output voltage and load current are defined by the power stage specification. This leaves the inductor value as the only design parameter to maintain continuous conduction mode. The minimum value of inductor to maintain continuous conduction mode can be determined by the following example.

Referring to the typical buck application circuit in Figure 5, the value can be calculated from the desired peak-to-peak LED ripple current in the inductor. Typically, such ripple current is selected to be 30% of the nominal LED current. In the example given here, the nominal current I_{LED} is 350mA. The next step is to determine the total voltage drop across the LED string. For example, when the string consists of 10 high brightness LEDs and each diode has a forward voltage drop of 3.3V at its nominal current, i.e. the total LED voltage drop V_{LEDS} is 33V.

Equation :

$$D = \frac{V_{LEDS}}{V_{IN}} \quad (2)$$

$$t_{ON} = \frac{D}{f_{OSC}} \quad (3)$$

$$L \geq \frac{(V_{IN} - V_{LEDS}) \times t_{ON}}{0.3 \times I_{LED}} \quad (4)$$

$$R_{CS} = \frac{0.25}{I_{LED} + [0.5 \times (I_{LED} \times 0.3)]} \quad (5)$$

where I_{LED} unit is Ampere.

BW9910/A High Brightness LED Driver

Assuming the nominal rectified input voltage $V_{IN} = 120V \times 1.414 = 169V$, the switching duty ratio can be determined as follows :

$$D = \frac{V_{LEDS}}{V_{IN}} = \frac{33}{169} = 0.195 \quad (6)$$

Then, in this example, given the switching frequency, $f_{OSC} = 50kHz$, the required on-time of the MOSFET transistor can be calculated as below :

$$t_{ON} = \frac{D}{f_{OSC}} = 3.91\mu s \quad (7)$$

The required minimum value of the inductor is given by :

$$L_{MIN} = \frac{(V_{IN} - V_{LEDS}) \times t_{ON}}{0.3 \times I_{LED}} = 5.06mH \quad (8)$$

Input Bulk Capacitor

An input filter capacitor should be designed to hold the rectified AC voltage above twice the LED string voltage throughout the AC line cycle. Assuming 15% relative voltage ripple across the capacitor, a simplified formula for the minimum value of the bulk input capacitor is given by :

Equation :

$$C_{IN} \geq \frac{P_{IN} \times (1 - D_{CH})}{\sqrt{2} \times V_{LINE(MIN)} \times 2f_L \times \Delta V_{DC(MAX)}} \quad (9)$$

where

D_{CH} : C_{IN} capacity charge work period, generally about 0.20 ~ 0.25,

f_L : input frequency for full range ($85V_{RMS} \sim 265V_{RMS}$),

$\Delta V_{DC(MAX)}$ should be set 10% ~ 15% of $\sqrt{2}V_{LINE(MIN)}$

If the capacitor has a 15% voltage ripple then a simplified formula for the minimum value of the bulk input capacitor approximates to :

$$C_{MIN} = \frac{I_{LED} \times V_{LEDS} \times 0.06}{V_{IN}^2} \quad (10)$$

$C_{MIN} = 24\mu F$, a value $33\mu F/250V$ can be used.

A passive PFC circuit at the input requires using two series connected capacitors at the place of calculated C_{MIN} . Each of these identical capacitors should be rated for $\frac{1}{2}$ of the input voltage and have twice as much capacitance.

Enable Function

The BW9910/BW9910A can be turned off by pulling the PWM_D pin to ground. When the device is disabled, the BW9910/BW9910A draws quiescent current of less than 1.0mA.

Output Open Circuit Protection

When the buck topology is used, and the LED is connected in series with the inductor, there is no need for any protection against an open circuit condition in the LED string. Open LED connection means no switching and can be continuous. In this case, since the output voltage will be the same as input voltage, if there is a capacitor connected across the output, this capacitor should be able to withstand the peak value of the input voltage.

Thermal Shut Down

Thermal protection is added due to buck topology can generate large heat when operated with high voltage input. The over temperature protection is activated to shut down external MOSFET when the junction temperature (T_J) reaches $150^\circ C$. There is a $50^\circ C$ hysteresis to re-start the MOSFET.

DC-DC Low Voltage Applications

Boost LED Driver

BW9910/BW9910A can also be used in boost configurations – at reduced accuracy. The accuracy can be improved by measuring the LED current with an Op-Amp and use the Op Amp's output to drive the LD pin.

Refer to Figure 1, a boost LED driver is used when the total voltage drop of the output LED string is higher than the input supply voltage. For example, the boost topology can be appropriate when input voltage is supplied by a 48V power supply and the LED string consists of twenty HB LEDs, as the case may be for a street light.

BW9910/A High Brightness LED Driver

In a boost converter, when the external MOSFET is ON the energy is stored in the inductor which is then delivered to the output when the external MOSFET switches OFF. If the energy stored in the inductor is not fully depleted by the next switching cycle (continuous conduction mode) the DC conversion between input and output voltage is given by :

$$\frac{V_{LEDS}}{V_{IN}} = \frac{1}{1-D} \quad (11)$$

From the switching frequency, f_{OSC} , the on-time of the MOSFET can be calculated :

$$t_{ON} = \frac{D}{f_{OSC}} \quad (12)$$

From this the required inductor value can be determined by :

$$L \geq \frac{V_{IN} \times t_{ON}}{0.3 \times I_{LED}} \quad (13)$$

The boost topology LED driver requires an output capacitor to deliver current to the LED string during the time that the external MOSFET is on. In boost LED driver topologies if the LEDs should become open circuit, damage may occur to the power switch and so some form of detection should be present to provide over-voltage detection/protection.

Figure 1. DC-DC Boost LED Driver

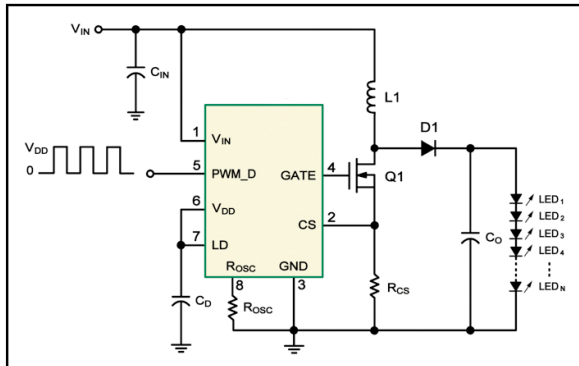

Buck-Boost (Fly-Back) LED Driver

Refer Figure 2, the buck-boost power conversion topology can be used when the forward voltage drop of the LED string is higher, equal or lower than the input supply voltage. For example, the buck-boost topology can be appropriate when input voltage is supplied by 24V system bus for trucks (voltage at supply battery is between 18V and 32V) and output string consists of six to nine HB LEDs, as the case may be for tail and break signal lights.

In the buck-boost converter, the energy from the input source is first stored in the inductor or fly-back transformer when the switching transistor is ON. The energy is then delivered to the output during the OFF time of the transistor. When the energy stored in the fly-back inductor is not fully depleted by the next switching cycle (continuous conduction mode) the DC conversion between input and output voltage is given by :

$$\frac{V_{LEDS}}{V_{IN}} = \frac{D}{1-D} \quad (14)$$

or

$$D = \frac{V_{LEDS}}{V_{IN} + V_{LEDS}} \quad (15)$$

The output voltage can be either higher or lower than the input voltage, depending on duty ratio.

Let us discuss the above example of 24V battery system LED driver that needs to drive six HB LEDs ($V_F = 3.3V$) at 350mA.

Knowing the nominal input voltage $V_{IN} = 24V$, the nominal duty ratio can be determined as below :

$$D = \frac{3.3 \times 6}{24 + 3.3 \times 6} = 0.45$$

Then, given the switching frequency, in this example $f_{OSC} = 50kHz$, the required on-time of the MOSFET transistor can be calculated :

$$t_{ON} = \frac{D}{f_{OSC}} = 9\mu s$$

BW9910/A High Brightness LED Driver

The required minimum value of the inductor is given by :

$$L_{\text{MIN}} = \frac{V_{\text{IN}} \times t_{\text{ON}}}{0.3 \times I_{\text{LED}}} = 2.05\text{mH}$$

So, use 2.2mH

Output Capacitor

Unlike the buck topology, the buck-boost converter requires an output filter capacitor to deliver power to the LED string during the ON time of the MOSFET.

In order to reduce the current ripple on the LED, this capacitor must have impedance that is much lower than the dynamic impedance R_{OUT} of the LED string. If we assume $R_{\text{OUT}} = 3\Omega$ in our example, in order to attenuate the switching ripple by a factor of 10, a capacitor with equivalent series resistance (ESR) of 0.3Ω is needed. A chip SMT tantalum capacitor can be selected for this purpose.

Figure 2. DC-DC Buck-Boost LED Driver (BW9910 for 24V Battery System)

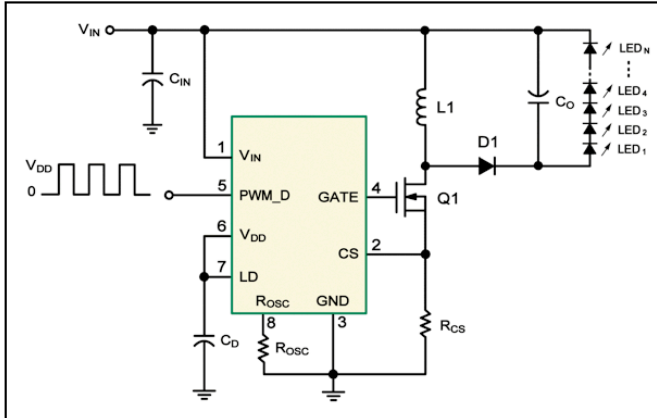

Buck LED Driver

The buck power conversion topology can be used when the LED string voltage is needed to be lower than the input supply voltage. The design procedure for a buck LED driver outlined in the previous sections can be applied to the low voltage LED drivers as well. However, the designer must keep in mind that the input voltage must be maintained higher than 2 times the forward voltage drop across the LEDs. This limitation is related to the output current instability that may develop when the BW9910/BW9910A buck converter operates at a duty cycle greater than 0.5. This instability reveals itself as an

oscillation of the output current at a sub-harmonic of the switching frequency.

Benefiting from the BW9910/BW9910A inherited high voltage feature, rectified DC high voltage ($V_{\text{DC}} = V_{\text{AC}} \times 1.414$) can be directly fed into power pin to achieve high duty cycle, which is only limited by $V_{\text{OUT}} / V_{\text{IN}}$, to optimize design efficiency. This solution can easily achieve above 90% efficiency. However, if the duty cycle is configured to reach above more than 50%, some instability called sub-harmonics oscillation (SBO) will occur.

The best solution is to adopt the so-called constant off-time operation as shown in Figure 4 and 6. To set operating frequency, the resistor (R_{OSC}) is connected to ground by default. This resistor can alternatively be connected to gate of MOSFET to force the BW9910/BW9910A to enter constant off-time mode which will decrease duty cycle from 50% by increase total period, $t_{\text{ON}} + t_{\text{OFF}}$. Normally, fixed frequency design is chosen as shown in Figure 3 because it has better efficiency.

For general LED lighting application, PFC becomes a necessary factor in order to meet the international standard of solid state lighting. If passive valley-fill PFC is chosen, then the BW9910/BW9910A is biased right after passive PFC stage.

The DC voltage rail V_{IN} , is halved and it will easily create a more than 50% duty cycle for the same LED loading due to $V_{\text{OUT}} / V_{\text{IN}}$ ratio is doubled. A SBO noise can be generated. In this case, the constant off-time mode as shown in Figure 6 should be chosen.

Example :

$V_{\text{IN}} : V_{\text{AC}} 110\text{V}$ with passive PFC

$V_{\text{OUT}} : \text{Consisting of } 1\text{W HB LED with nominal } V_{\text{F}} = 3.3\text{V}$

$V_{\text{IN(MIN)}} : \text{After rectified and passing PFC stage, the actual DC rail will become}$

$$V_{\text{IN(MIN)}} = 110\text{V} \times 1.414 / 2 = 77.7\text{V}_{\text{DC}}$$

The duty cycle, $D = V_{\text{OUT}} / V_{\text{IN(MIN)}}$, will reach above 50% when voltage drop of LED string, as the V_{OUT} is more than $77.7/2 = 38.8\text{V}$. Another word, if any string consisting of $38.8/3.3 \approx 12$ LEDs in a series, SBO will occur.

BW9910/A High Brightness LED Driver

In this case, the resistor (R_{OSC}) should be connected between pin 8, R_{OSC} , and pin 4, GATE to set the BW9910/BW9910A operate in constant off-time mode to avoid SBO.

Figure 3. Fixed Frequency Mode

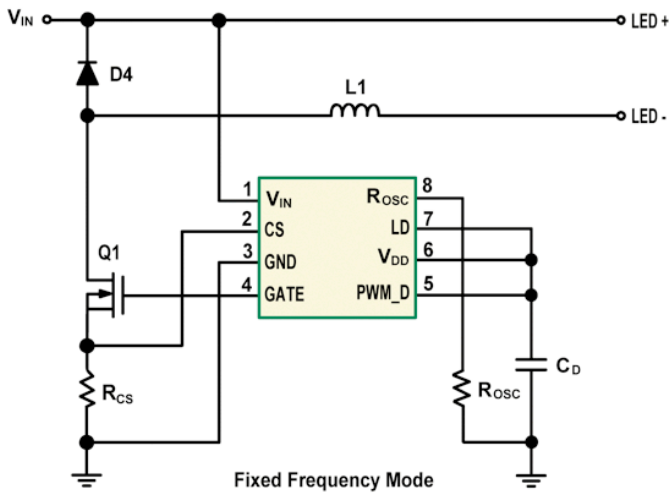

Figure 4. Constant Off-Time Mode

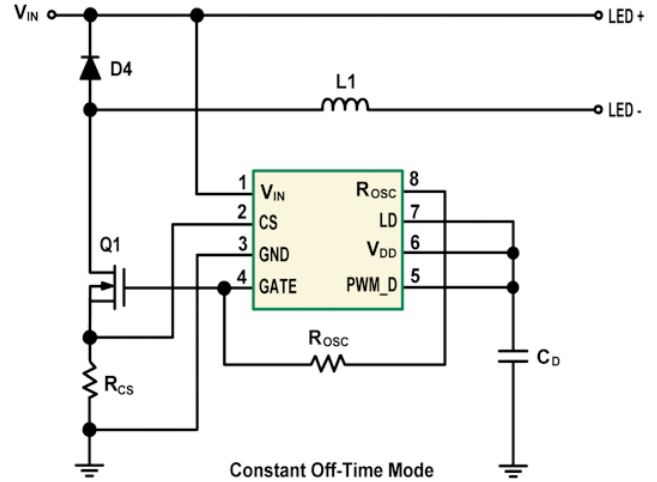
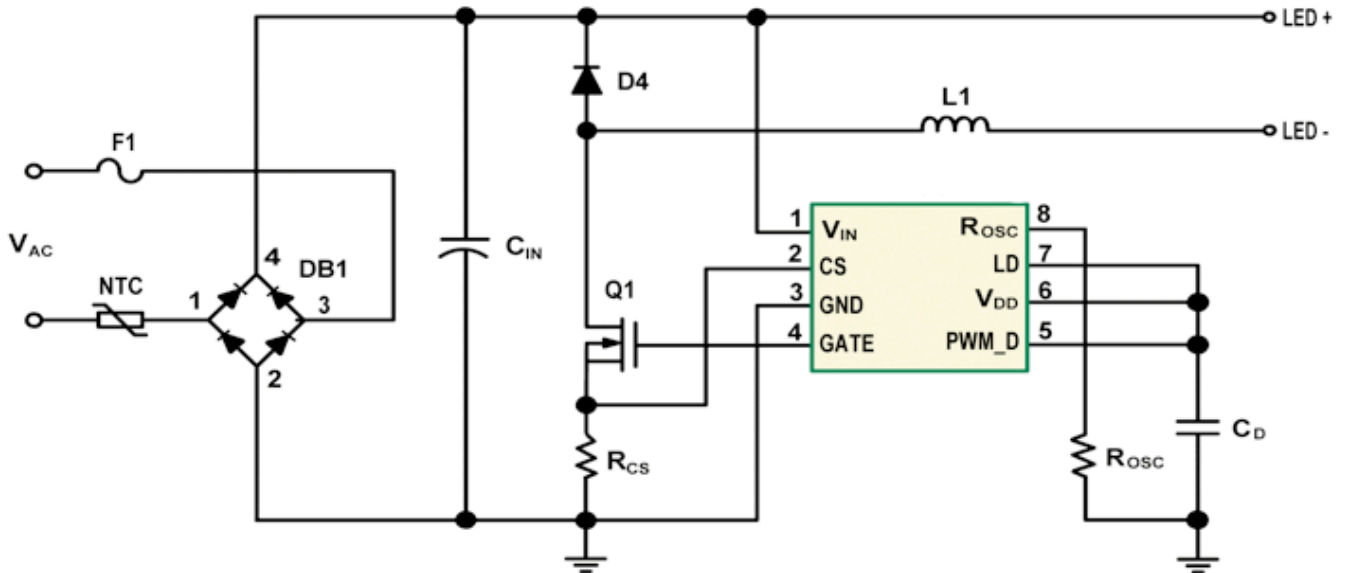
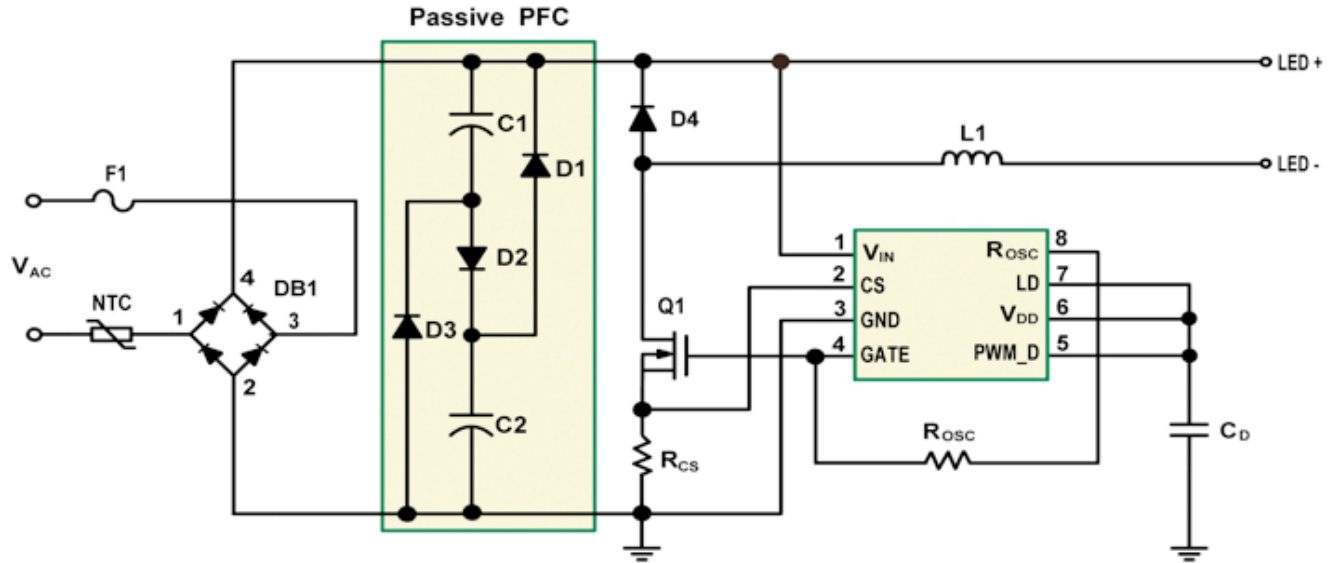

Figure 5. Typical Application Circuit without PFC in Fixed Frequency Mode



BW9910/A High Brightness LED Driver

Figure 6. Typical Application Circuit with Valley-Fill PFC in Constant Off-Time mode



BW9910/A High Brightness LED Driver

Package Outline Dimensions

Package Type : SOP-8 / SO8-EP

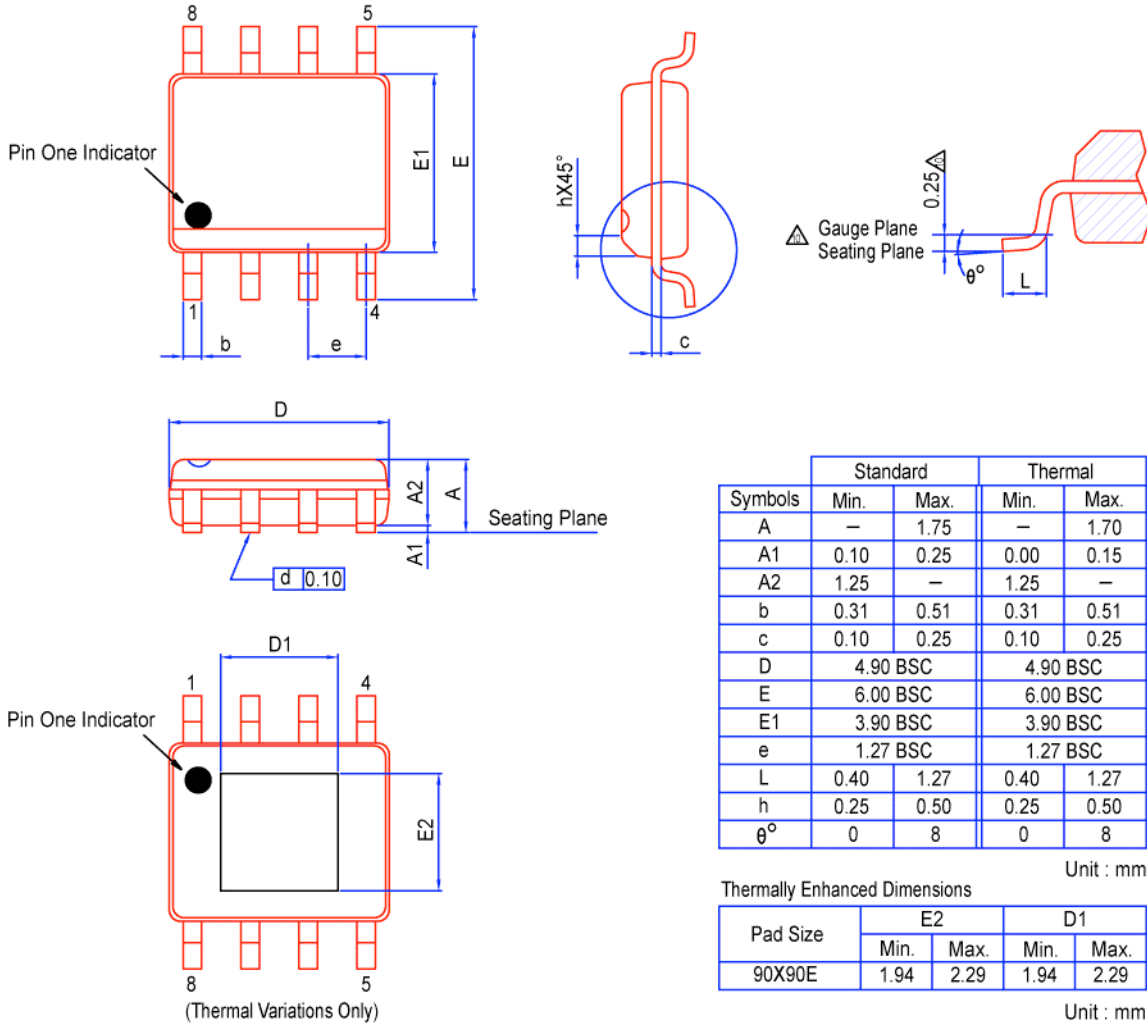

Marking Information

SOP-8	SO8-EP	SOP-8	SO8-EP
<p>BW9910 XYWWZ</p>	<p>BW9910 XYWWZ</p>	<p>BW9910A XYWWZ</p>	<p>BW9910A XYWWZ</p>

X = A/T Site, YY = Year, WW = Working Week, Z = Device Version



BW9910/A High Brightness LED Driver

Legal Disclaimer Notice

Disclaimer

ALL PRODUCT, PRODUCT SPECIFICATIONS AND DATA ARE SUBJECT TO CHANGE WITHOUT NOTICE TO IMPROVE RELIABILITY, FUNCTION OR DESIGN OR OTHERWISE.

Bruckewell Technology Inc., its affiliates, agents, and employees, and all persons acting on its or their behalf (collectively, "Bruckewell"), disclaim any and all liability for any errors, inaccuracies or incompleteness contained in any datasheet or in any other disclosure relating to any product.

Bruckewell makes no warranty, representation or guarantee regarding the suitability of the products for any particular purpose or the continuing production of any product. To the maximum extent permitted by applicable law, Bruckewell disclaims

- (i) Any and all liability arising out of the application or use of any product.
- (ii) Any and all liability, including without limitation special, consequential or incidental damages.
- (iii) Any and all implied warranties, including warranties of fitness for particular purpose, non-infringement and merchantability.

Statements regarding the suitability of products for certain types of applications are based on Bruckewell's knowledge of typical requirements that are often placed on Bruckewell products in generic applications.

Such statements are not binding statements about the suitability of products for a particular application. It is the customer's responsibility to validate that a particular product with the properties described in the product specification is suitable for use in a particular application. Parameters provided in datasheets and/or specifications may vary in different applications and performance may vary over time.

Product specifications do not expand or otherwise modify Bruckewell's terms and conditions of purchase, including but not limited to the warranty expressed therein.