

Technical Data

DIODE



maximum ratings

Voltage, Reverse (VR)	600.0	V	NO.	BYW88-600
Voltage, Reverse Peak (VRM)	600.0	V	TYPE	SILICON
Current at VR = 0V (IO)		A		
Current Average Rectified (IF)	12.0	A		
Current Surge Peak (IZM)		A	CASE	DO-4_UNF
Current, Surge (IFM) at tp = 10 ms	230.0	A		CATHODE TO STUD
Max. Power Dissipation (PT) at TC = °C		W		
Max. Thermal Resistance (Rth J-C)	2.0	°C/W		
Max. Junction Temperature (TJ)	150.0	°C		

PERFORMANCE CHARACTERISTICS at $T_c = 25^\circ\text{C}$, unless otherwise noted

NO.	SYMBOL	CONDITIONS	MIN.	MAX.	UNITS
1.	IR	VR = 600.0 V	-	50.0	μA
2.	IR	VR = 600.0 V, TJ = 125.0° C	-	3.0	mA
3.	VF	IF = 35.0 A (1)	-	1.25	V
4.					
5.					
6.					
7.					
8.					
9.					
10.					
11.					
12.					
13.					
14.					
15.					
16.					
17.					
18.					
19.					
20.					

Notes (1) pulse-tested $t_p \leq 300 \mu\text{s}$, duty cycle $\leq 2\%$

DIMENSIONS
in mm

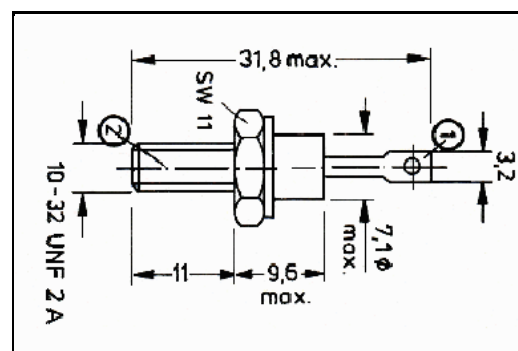

Marking BYW88-600
Customer GENERAL PURPOSE