

RoHS Compliant Product
A suffix of "-C" specifies halogen & lead-free

FEATURES

- Standard Zener Breakdown Voltage Range: 2.4V to 43V
- Steady State Power Rating of 500 mW
- Small Body Outline Dimensions: 3.70 mm x 1.60 mm
- Low Body Height: 1.05 mm
- Package Weight: 10.00 mg / unit
- ESD Rating of Class 3 (> 16 KV) per Human Body Model

MECHANICAL DATA

- Case: SOD-123, Void-Free, Transfer-Molded Plastic.
- Finish: All External Surfaces are Corrosion Resistant.
- Maximum Case Temperature for Soldering Purpose: 260 °C for 10 Seconds
- Polarity: Cathode Indicated by Polarity Band
- Flammability Rating: UL94V-0
- Mounting Position: Any

PACKAGE INFORMATION

Package	MPQ	Leader Size
SOD-123	3K	7' inch

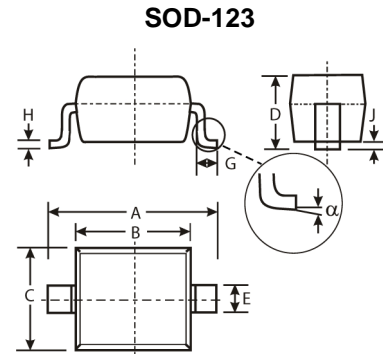

SOD-123		
Dim	Min	Max
A	3.55	3.85
B	2.55	2.85
C	1.40	1.70
D	-	1.35
E	0.55 Typical	
G	0.25	-
H	0.11 Typical	
J	-	0.10
α	0°	8°
All Dimensions in mm		

MAXIMUM RATINGS ($T_A = 25^\circ\text{C}$ unless otherwise specified)

Parameter	Symbol	Value	Unit
Forward Voltage @ $I_F=10\text{mA}$ ²	V_F	0.9	V
Power Dissipation ¹ , Derate above 25°C.	P_D	500	mW
Thermal Resistance Junction to Ambient Air ¹	$R_{\theta JA}$	357	°C / W
Operating and Storage Temperature Range	T_J, T_{STG}	-65 ~ 150	°C

Note:

1. Device mounted on ceramic PCB; 7.6mm×9.4mm×0.87mm with pad areas 25mm².
2. Short duration test pulse used in minimize self-heating effect.
3. $f = 1 \text{ K Hz}$.

ELECTRICAL RATINGS ($T_A = 25^\circ\text{C}$ unless otherwise specified)

TYPE NUMBER	MARKING	ZENER VOLTAGE RANGE ²				MAXIMUM ZENER IMPEDANCE ³			MAXIMUM REVERSE CURRENT ²		Temperature Coefficient of Zener Voltage @ $I_Z = 5 \text{ mA}$ mV / °C	
		V_Z			@ I_Z	Z_{ZT} @ I_Z	Z_{ZK} @ I_{ZK}		I_R	V_R		
		Min	Nom	Max			Ω	Ω			mA	μA
		V	V	V	mA	Ω	Ω	mA	μA	V	Min	Max
BZT52C2V4	WX	2.2	2.4	2.6	5	100	600	1	50	1	-3.5	0
BZT52C2V7	W1	2.5	2.7	2.9	5	100	600	1	20	1	-3.5	0
BZT52C3V0	W2	2.8	3	3.2	5	95	600	1	10	1	-3.5	0
BZT52C3V3	W3	3.1	3.3	3.5	5	95	600	1	5	1	-3.5	0
BZT52C3V6	W4	3.4	3.6	3.8	5	90	600	1	5	1	-3.5	0
BZT52C3V9	W5	3.7	3.9	4.1	5	90	600	1	3	1	-3.5	0
BZT52C4V3	W6	4.0	4.3	4.6	5	90	600	1	3	1	-3.5	0
BZT52C4V7	W7	4.4	4.7	5	5	80	500	1	3	2	-3.5	0.2
BZT52C5V1	W8	4.8	5.1	5.4	5	60	480	1	2	2	-2.7	1.2
BZT52C5V6	W9	5.2	5.6	6	5	40	400	1	1	2	-2	2.5
BZT52C6V2	WA	5.8	6.2	6.6	5	10	150	1	3	4	0.4	3.7
BZT52C6V8	WB	6.4	6.8	7.2	5	15	80	1	2	4	1.2	4.5
BZT52C7V5	WC	7	7.5	7.9	5	15	80	1	1	5	2.5	5.3
BZT52C8V2	WD	7.7	8.2	8.7	5	15	80	1	0.7	5	3.2	6.2
BZT52C9V1	WE	8.5	9.1	9.6	5	15	100	1	0.5	6	3.8	7
BZT52C10	WF	9.4	10	10.6	5	20	150	1	0.2	7	4.5	8
BZT52C11	WG	10.4	11	11.6	5	20	150	1	0.1	8	5.4	9
BZT52C12	WH	11.4	12	12.7	5	25	150	1	0.1	8	6	10
BZT52C13	WI	12.4	13	14.1	5	30	170	1	0.1	8	7	11
BZT52C15	WJ	13.8	15	15.6	5	30	200	1	0.1	10.5	9.2	13
BZT52C16	WK	15.3	16	17.1	5	40	200	1	0.1	11.2	10.4	14
BZT52C18	WL	16.8	18	19.1	5	45	225	1	0.1	12.6	12.4	16
BZT52C20	WM	18.8	20	21.2	5	55	225	1	0.1	14	14.4	18
BZT52C22	WN	20.8	22	23.3	5	55	250	1	0.1	15.4	16.4	20
BZT52C24	WO	22.8	24	25.6	5	70	250	1	0.1	16.8	18.4	22
BZT52C27	WP	25.1	27	28.9	2	80	300	0.5	0.1	18.9	21.4	25.3
BZT52C30	WQ	28	30	32	2	80	300	0.5	0.1	21	24.4	29.4
BZT52C33	WR	31	33	35	2	80	325	0.5	0.1	23.1	27.4	33.4
BZT52C36	WS	34	36	38	2	90	350	0.5	0.1	25.2	30.4	37.4
BZT52C39	WT	37	39	41	2	130	350	0.5	0.1	27.3	33.4	41.2
BZT52C43	WU	40	43	46	5	100	700	1	0.1	32	10	12

Notes:

- Valid provided that device terminals are keep at ambient temperature.
- Test with pulses. period = 5ms, pulse width = 300 μA
- f = 1KHz

CHARACTERISTIC CURVES

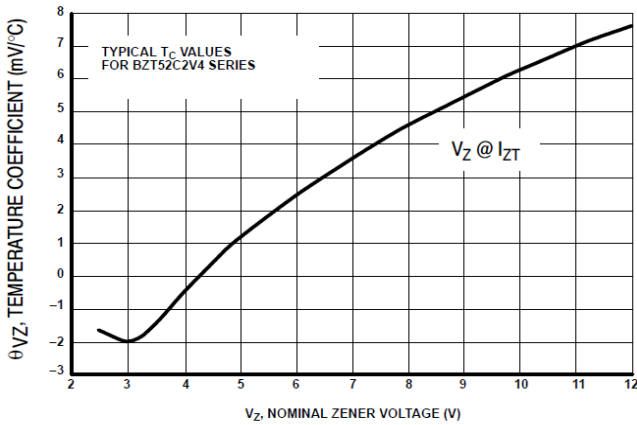

Figure 1. Temperature Coefficients
(Temperature Range -55°C to $+150^{\circ}\text{C}$)

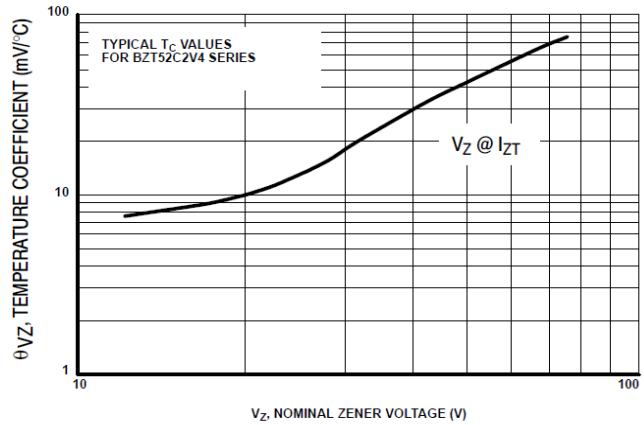

Figure 2. Temperature Coefficients
(Temperature Range -55°C to $+150^{\circ}\text{C}$)

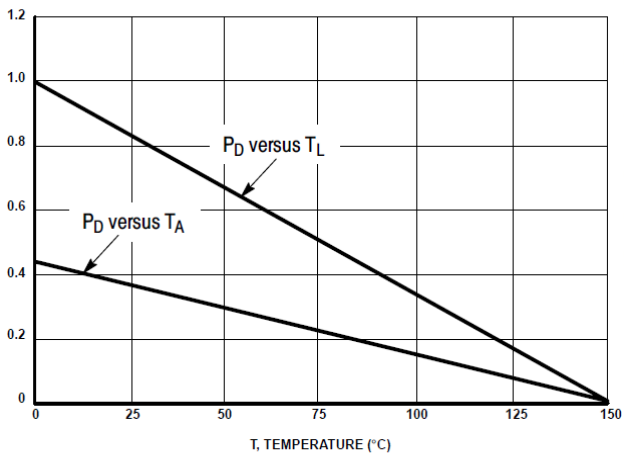

Figure 3. Steady State Power Derating

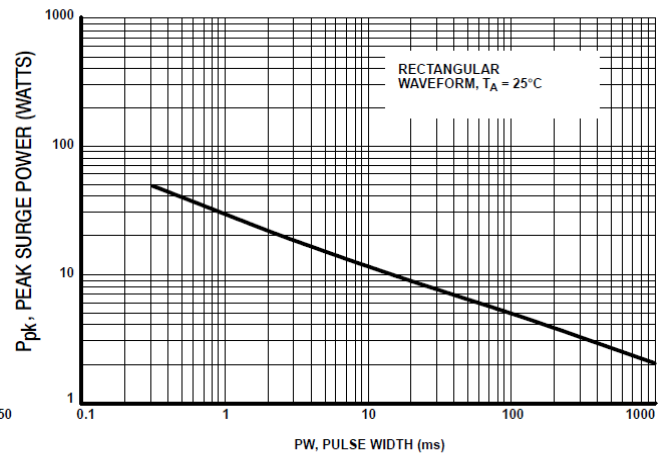

Figure 4. Maximum Nonrepetitive Surge Power

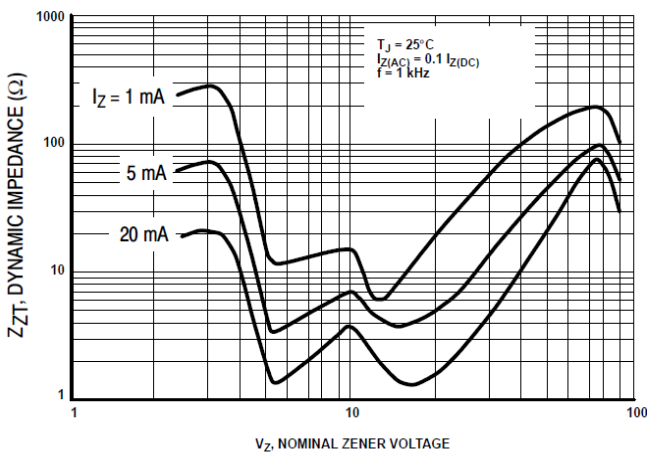

Figure 5. Effect of Zener Voltage on Zener Impedance

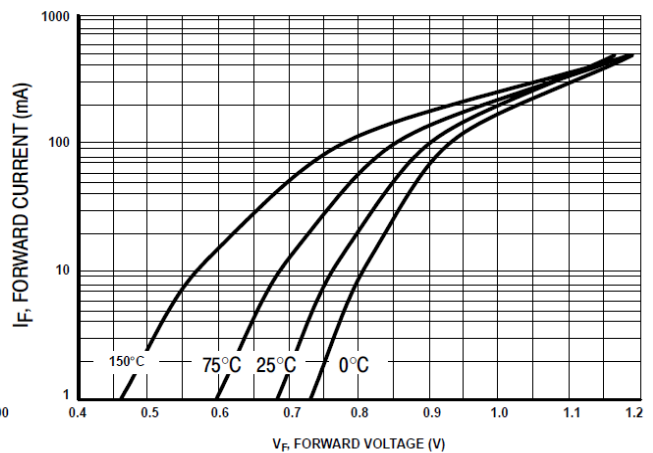

Figure 6. Typical Forward Voltage

CHARACTERISTIC CURVES

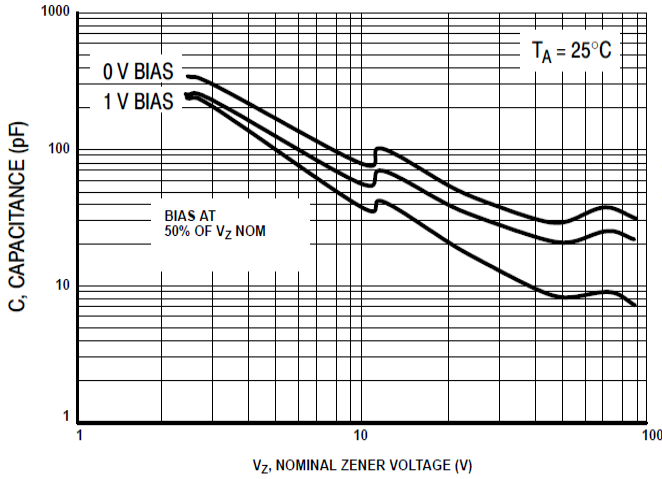

Figure 7. Typical Capacitance

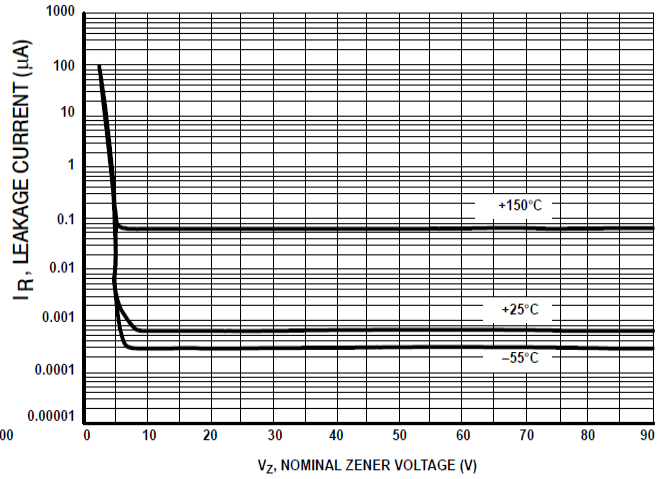
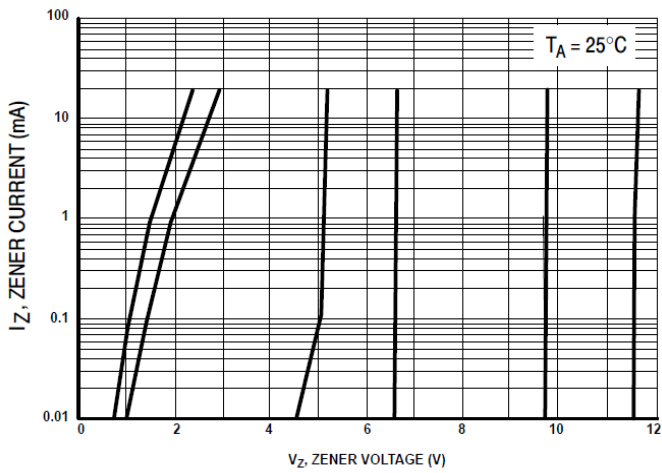
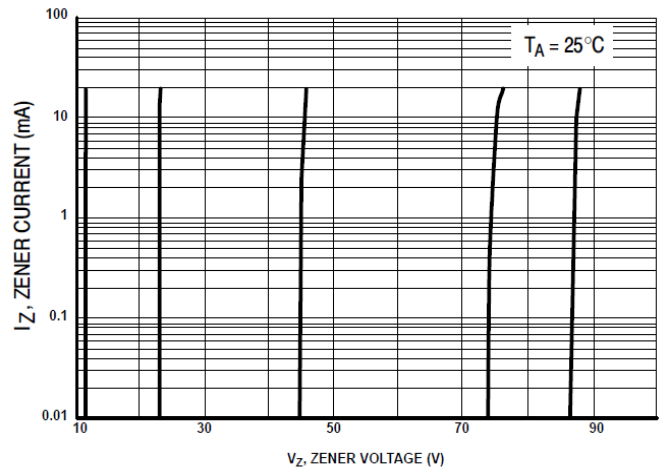

Figure 8. Typical Leakage Current



**Figure 9. Zener Voltage versus Zener Current
(V_Z Up to 12 V)**



**Figure 10. Zener Voltage versus Zener Current
(12 V to 91 V)**