



REGULATOR DIODES



A range of diffused silicon diodes in plastic envelopes, intended for use as voltage regulator and transient suppressor diodes in medium power regulators and transient suppression circuits.

The series consists of the following types: BZX70-C7V5 to BZX70-C75.

QUICK REFERENCE DATA

			voltage regulator	transient suppressor	
Working voltage (5% range)	V_Z	nom.	7,5 to 75	—	V
Stand-off voltage	V_R		—	5,6 to 56	V
Total power dissipation	P_{tot}	max.	2,5	—	W
Non-repetitive peak reverse power dissipation	P_{RSM}	max.	—	700	W

MECHANICAL DATA

Dimensions in mm

Fig. 1 SOD-18.

The rounded end indicates the cathode.

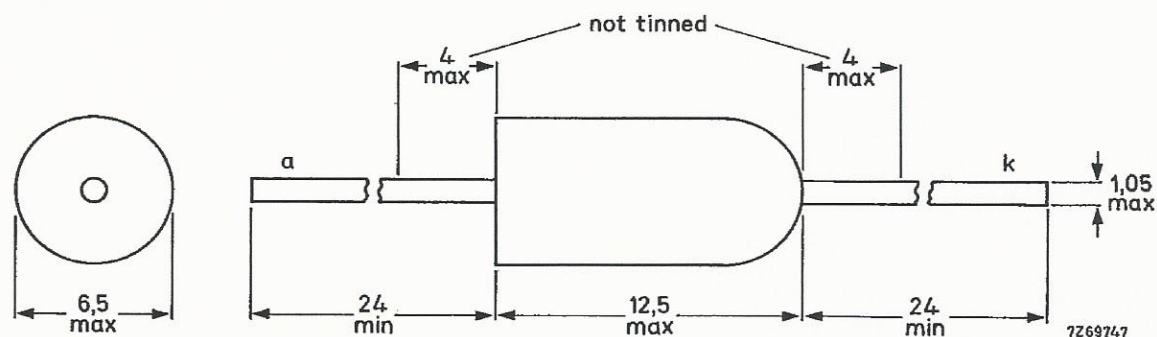

RATINGS

Limiting values in accordance with the Absolute Maximum System (IEC 134)

Peak working current	I_{ZM}	max.	5 A
Average forward current (averaged over any 20 ms period)	$I_{F(AV)}$	max.	1 A
Non-repetitive peak reverse current $T_j = 25\text{ °C}$ prior to surge; $t_p = 1\text{ ms}$ (exponential pulse); BZX70-C7V5 to BZX70-C75	I_{RSM}	max.	44 to 6 A
Total power dissipation at $T_{amb} = 25\text{ °C}$; with 10 mm tie-points	P_{tot}	max.	2,5 W
Non-repetitive peak reverse power dissipation $T_j = 25\text{ °C}$ prior to surge; $t_p = 1\text{ ms}$ (exponential pulse)	P_{RSM}	max.	700 W
Storage temperature	T_{stg}		-55 to + 150 °C
Junction temperature	T_j	max.	150 °C

THERMAL RESISTANCE

From junction to ambient in free air

see Figs 4 and 5

CHARACTERISTICS

Forward voltage $I_F = 1\text{ A}$; $T_{amb} = 25\text{ °C}$	V_F	<	1,5 V
--	-------	---	-------

OPERATION AS A VOLTAGE REGULATOR

Dissipation and heatsink considerations

a. Steady-state conditions

The maximum permissible steady-state dissipation $P_{s \max}$ is given by the relationship

$$P_{s \max} = \frac{T_{j \max} - T_{\text{amb}}}{R_{\text{th } j-a}}$$

where: $T_{j \max}$ is the maximum permissible operating junction temperature

T_{amb} is the ambient temperature

$R_{\text{th } j-a}$ is the total thermal resistance from junction to ambient

b. Pulse conditions (see Fig. 2)

The maximum permissible pulse power $P_{p \max}$ is given by the formula

$$P_{p \max} = \frac{(T_{j \max} - T_{\text{amb}}) - (P_s \cdot R_{\text{th } j-a})}{R_{\text{th } t}}$$

where: P_s is any steady-state dissipation excluding that in pulses

$R_{\text{th } t}$ is the effective transient thermal resistance of the device between junction and ambient.

It is a function of the pulse duration t_p and duty factor δ .

δ is the duty factor (t_p/T)

The steady-state power P_s when biased in the zener direction at a given zener current can be found from Fig. 3. With the additional pulse power dissipation $P_{p \max}$ calculated from the above expression, the total peak zener power dissipation $P_{\text{tot}} = P_{\text{ZRM}} = P_s + P_p$. From Fig. 3 the corresponding maximum repetitive peak zener current at P_{tot} can now be read. This repetitive peak zener current is subject to the absolute maximum rating. For pulse durations longer than the temperature stabilization time of the diode t_{stab} , the maximum permissible repetitive peak dissipation P_{ZRM} is equal to the steady-state power P_s . The temperature stabilization time for the BZX70 is 100 seconds.

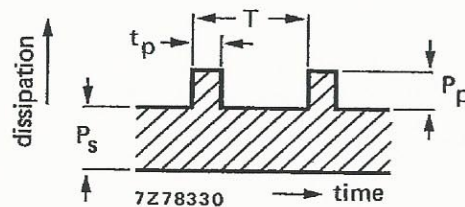

Fig. 2.

NOTES WHEN OPERATING AS A TRANSIENT SUPPRESSOR

1. Recommended stand-off voltage is defined as being the maximum reverse voltage to be applied without causing conduction in the avalanche mode or significant reverse dissipation.
2. Maximum clamping voltage is the maximum reverse avalanche breakdown voltage which will appear across the diode at the specified pulse duration and junction temperature.
3. Duration of an exponential pulse is defined as the time taken for the pulse to fall to 37% of its initial value. It is assumed that energy content does not continue beyond twice this time.

BZX70 SERIES



CHARACTERISTICS – WHEN USED AS VOLTAGE REGULATOR DIODES; $T_{amb} = 25\text{ }^{\circ}\text{C}$

BZX70-...	working voltage $*V_Z$ V		differential resistance $*r_Z$ Ω		temperature coefficient $*S_Z$ mV/ $^{\circ}\text{C}$	test I_Z mA	reverse current at I_R μA	reverse voltage V_R V
	min.	max.	typ.	max.	typ.		max.	
C7V5	7.0	7.9	0.45	3.5	3.0	50	50	2.0
C8V2	7.7	8.7	0.45	3.5	4.0	50	20	5.6
C9V1	8.5	9.6	0.55	4.0	5.5	50	10	6.2
C10	9.4	10.6	0.75	4.0	7.0	50	10	6.8
C11	10.4	11.6	0.8	4.5	7.5	50	10	7.5
C12	11.4	12.7	0.85	5.0	8.0	50	10	8.2
C13	12.4	14.1	0.9	6.0	8.5	50	10	9.1
C15	13.8	15.6	1.0	8.0	10	50	10	10
C16	15.3	17.1	2.4	9.0	11	20	10	11
C18	16.8	19.1	2.5	11	12	20	10	12
C20	18.8	21.2	2.8	12	14	20	10	13
C22	20.8	23.3	3.0	13	16	20	10	15
C24	22.7	25.9	3.4	14	18	20	10	16
C27	25.1	28.9	3.8	18	20	20	10	18
C30	28	32	4.5	22	25	20	10	20
C33	31	35	5.0	25	30	20	10	22
C36	34	38	5.5	30	32	20	10	24
C39	37	41	12	35	35	10	10	27
C43	40	46	13	40	40	10	10	30
C47	44	50	14	50	45	10	10	33
C51	48	54	15	55	50	10	10	36
C56	52	60	17	63	55	10	10	39
C62	58	66	18	75	60	10	10	43
C68	64	72	18	90	65	10	10	47
C75	70	79	20	100	70	10	10	51

*At test I_Z ; measured using a pulse method with $t_p \leq 100\ \mu\text{s}$ and $\delta \leq 0.001$ so that the values correspond to a T_j of approximately $25\text{ }^{\circ}\text{C}$.

Regulator diodes

CHARACTERISTICS – WHEN USED AS TRANSIENT SUPPRESSOR DIODES; $T_{amb} = 25\text{ }^{\circ}\text{C}$

clamping voltage at $t_p = 500\text{ }\mu\text{s}$ exp. pulse $V_{(CL)R}$ V		non-repetitive peak reverse current I_{RSM} A	reverse current at recommended stand-off voltage I_R mA		V_R V	BZX70-...
typ.	max.		max.			
9	10	20	0.5	5.6		C7V5
10	11.2	20	0.5	6.2		C8V2
11	12.5	20	0.5	6.8		C9V1
12	14	20	0.1	7.5		C10
13.5	15.5	20	0.1	8.2		C11
15	17.5	20	0.1	9.1		C12
17	19	20	0.1	10		C13
19	21	20	0.1	11		C15
21	23	20	0.1	12		C16
23	26	20	0.1	13		C18
22	26	10	0.1	15		C20
25	29	10	0.1	16		C22
28	33	10	0.1	18		C24
32	38	10	0.1	20		C27
36	43	10	0.1	22		C30
41	48	10	0.1	24		C33
47	54	10	0.1	27		C36
44	52	5	0.1	30		C39
49	58	5	0.1	33		C43
56	65	5	0.1	36		C47
63	72	5	0.1	39		C51
71	82	5	0.1	43		C56
80	93	5	0.1	47		C62
89	104	5	0.1	51		C68
98	116	5	0.1	56		C75



SOLDERING AND MOUNTING INSTRUCTIONS

1. When using a soldering iron, diodes may be soldered directly into the circuit, but heat conducted to the junction should be kept to a minimum.
2. Diodes may be dip-soldered at a solder temperature of 245 °C for a maximum soldering time of 5 seconds. The case temperature during dip-soldering must not at any time exceed the maximum storage temperature. These recommendations apply to a diode with the anode end mounted flush on a printed-circuit board having punched-through holes. For mounting the anode end onto a printed-circuit board, the diode must be spaced at least 5 mm from the underside of the printed-circuit board having punched-through holes, or 5 mm from the top of the printed circuit board having plated-through holes.
3. Care should be taken not to bend the leads nearer than 1,5 mm from the seal; exert no axial pull when bending.