

### Features

- Planar Die Construction
- 350mW Power Dissipation
- 2.4V – 51V Nominal Zener Voltage
- 5% Standard Vz Tolerance
- Designed for Surface Mount Application
- Plastic Material – UL Recognition Flammability Classification 94V-0

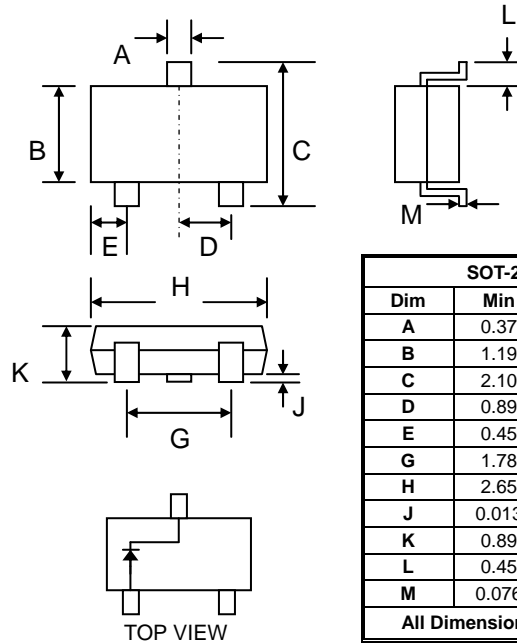

SOT-23		
Dim	Min	Max
A	0.37	0.51
B	1.19	1.40
C	2.10	2.50
D	0.89	1.05
E	0.45	0.61
G	1.78	2.05
H	2.65	3.05
J	0.013	0.15
K	0.89	1.10
L	0.45	0.61
M	0.076	0.178
All Dimensions in mm		

### Mechanical Data

- Case: SOT-23, Molded Plastic
- Terminals: Plated Leads Solderable per MIL-STD-202, Method 208
- Polarity: See Diagram
- Weight: 0.008 grams (approx.)
- Mounting Position: Any
- Marking: Device Code
- **Lead Free: For RoHS / Lead Free Version, Add “-LF” Suffix to Part Number, See Page 5**

### Maximum Ratings @ $T_A=25^{\circ}\text{C}$ unless otherwise specified

Characteristic	Symbol	Value	Unit
Peak Pulse Power Dissipation at $T_A = 25^{\circ}\text{C}$ (Note 1)	$P_D$	350	mW
Forward Voltage @ $I_F = 10\text{mA}$	$V_F$	0.9	V
Thermal Resistance Junction to Ambient (Note 1, 2)	$R_{JA}$	357	$^{\circ}\text{C}/\text{W}$
Operating and Storage Temperature Range	$T_j, T_{STG}$	-65 to +150	$^{\circ}\text{C}$

Note: 1. Mounted on FR-4 PCB with minimum recommended pad layout.  
 2. Thermal resistance measurement obtained via infrared scan method.

# BZX84C2V4 – BZX84C51

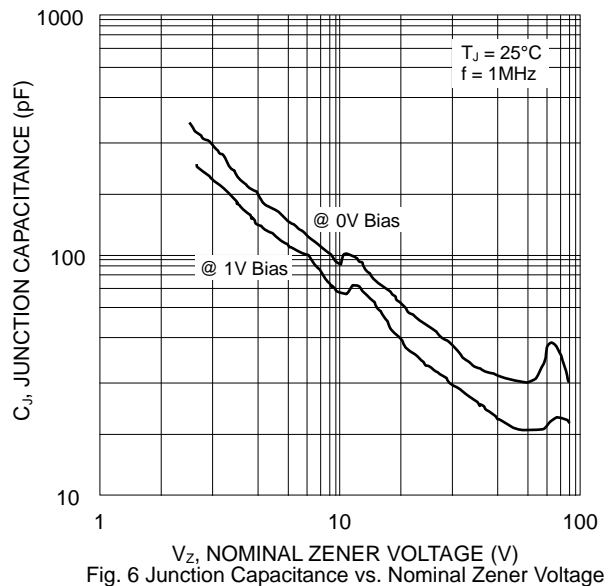
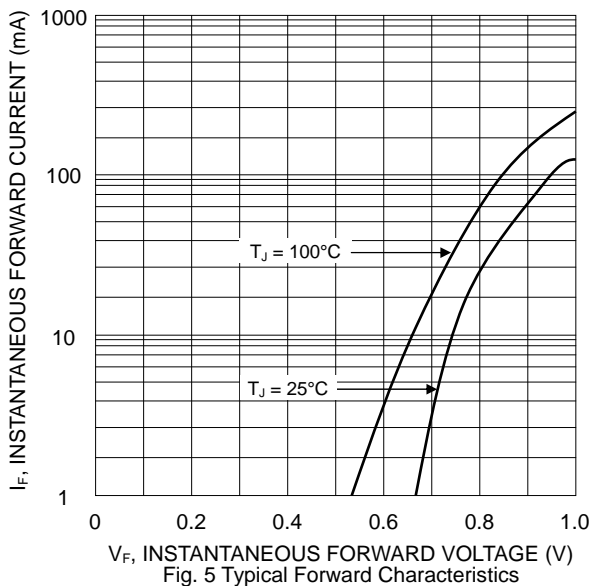
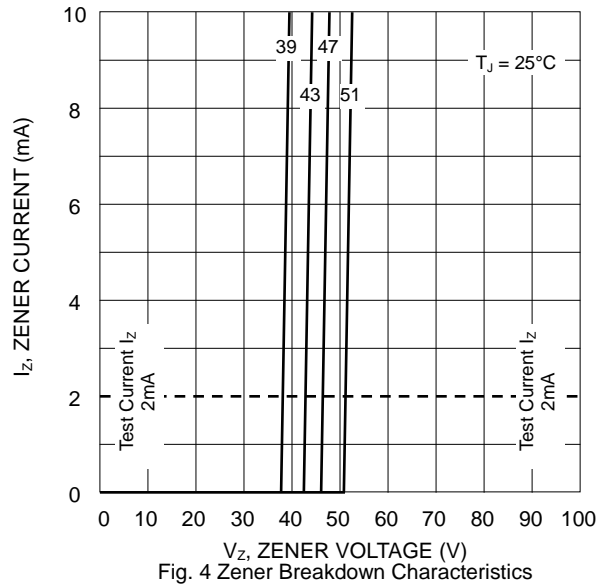
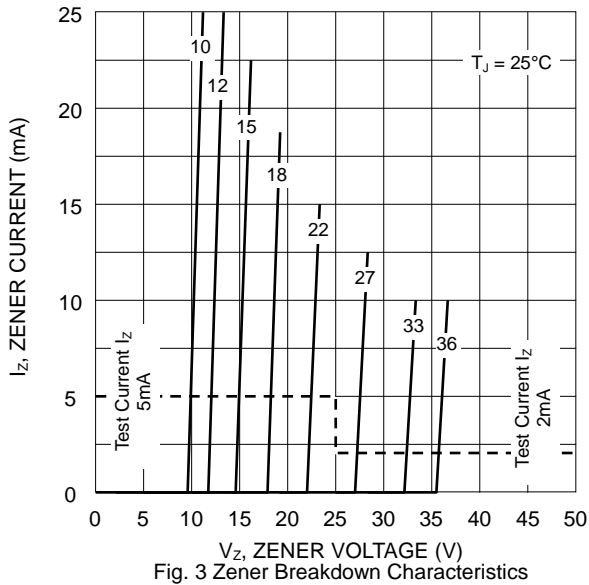
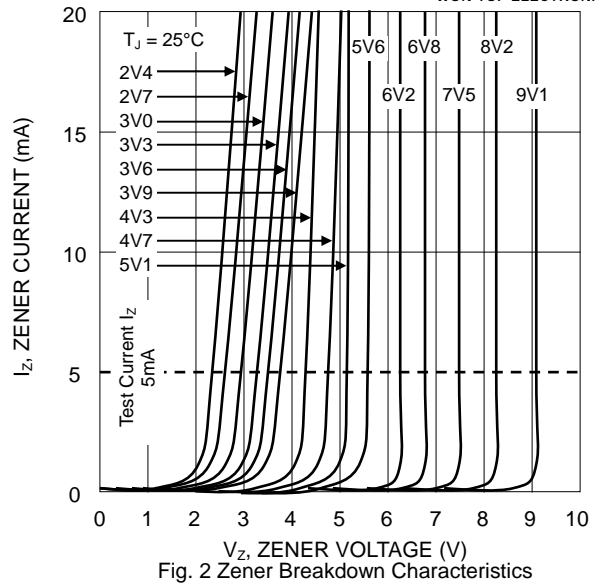
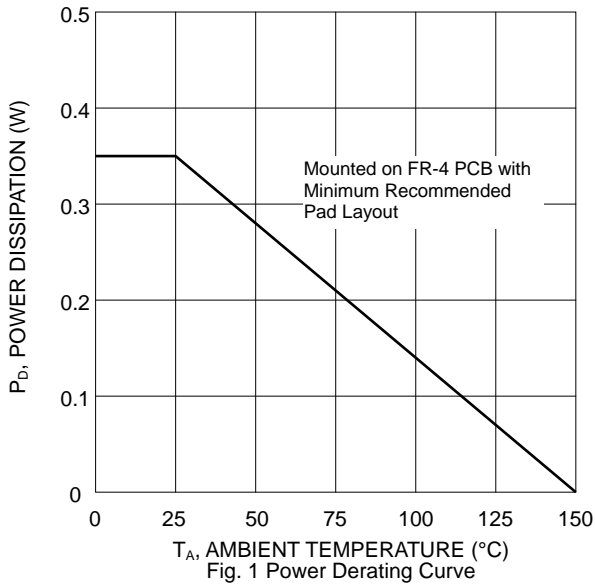

**Electrical Characteristics (@T<sub>A</sub>=25°C unless otherwise specified) Table 1**

Type Number (Note 1)	Device Marking Code (Note 2)		Zener Voltage Range (Note 3)			Maximum Zener Impedance (Note 4)				Max Reverse Leakage Current		Temp. Coefficient of Zener Voltage @ I <sub>ZT</sub> (mV/K)	
			V <sub>Z</sub> @ I <sub>ZT</sub>			Z <sub>ZT</sub> @ I <sub>ZT</sub>		Z <sub>ZK</sub> @ I <sub>ZK</sub>		I <sub>R</sub>	@ V <sub>R</sub>		
	TW	CN	Nom (V)	Min (V)	Max (V)	( )	(mA)	( )	(mA)	(μA)	(V)	Min	Max
BZX84C2V4	W1	Z11	2.4	2.2	2.6	100	5.0	600	1.0	50	1.0	-3.5	0
BZX84C2V7	W2	Z12	2.7	2.5	2.9	100	5.0	600	1.0	20	1.0	-3.5	0
BZX84C3V0	W3	Z13	3.0	2.8	3.2	95	5.0	600	1.0	10	1.0	-3.5	0
BZX84C3V3	W4	Z14	3.3	3.1	3.5	95	5.0	600	1.0	5.0	1.0	-3.5	0
BZX84C3V6	W5	Z15	3.6	3.4	3.8	90	5.0	600	1.0	5.0	1.0	-3.5	0
BZX84C3V9	W6	Z16	3.9	3.7	4.1	90	5.0	600	1.0	3.0	1.0	-3.5	0
BZX84C4V3	W7	Z17	4.3	4.0	4.6	90	5.0	600	1.0	3.0	1.0	-3.5	0
BZX84C4V7	W8	Z1	4.7	4.4	5.0	80	5.0	500	1.0	3.0	2.0	-3.5	0.2
BZX84C5V1	W9	Z2	5.1	4.8	5.4	60	5.0	480	1.0	2.0	2.0	-2.7	1.2
BZX84C5V6	WA	Z3	5.6	5.2	6.0	40	5.0	400	1.0	1.0	2.0	-2.0	2.5
BZX84C6V2	WB	Z4	6.2	5.8	6.6	10	5.0	150	1.0	3.0	4.0	0.4	3.7
BZX84C6V8	WC	Z5	6.8	6.4	7.2	15	5.0	80	1.0	2.0	4.0	1.2	4.5
BZX84C7V5	WD	Z6	7.5	7.0	7.9	15	5.0	80	1.0	1.0	5.0	2.5	5.3
BZX84C8V2	WE	Z7	8.2	7.7	8.7	15	5.0	80	1.0	0.7	5.0	3.2	6.2
BZX84C9V1	WF	Z8	9.1	8.5	9.6	15	5.0	100	1.0	0.5	6.0	3.8	7.0
BZX84C10	WG	Z9	10	9.4	10.6	20	5.0	150	1.0	0.2	7.0	4.5	8.0
BZX84C11	WH	Y1	11	10.4	11.6	20	5.0	150	1.0	0.1	8.0	5.4	9.0
BZX84C12	WI	Y2	12	11.4	12.7	25	5.0	150	1.0	0.1	8.0	6.0	10.0
BZX84C13	WK	Y3	13	12.4	14.1	30	5.0	170	1.0	0.1	8.0	7.0	11.0
BZX84C15	WL	Y4	15	13.8	15.6	30	5.0	200	1.0	0.05	10.5	9.2	13.0
BZX84C16	WM	Y5	16	15.3	17.1	40	5.0	200	1.0	0.05	11.2	10.4	14.0
BZX84C18	WN	Y6	18	16.8	19.1	45	5.0	225	1.0	0.05	12.6	12.4	16.0
BZX84C20	WO	Y7	20	18.8	21.2	55	5.0	225	1.0	0.05	14.0	14.4	18.0
BZX84C22	WP	Y8	22	20.8	23.3	55	5.0	250	1.0	0.05	15.4	16.4	20.0
BZX84C24	WR	Y9	24	22.8	25.6	70	5.0	250	1.0	0.05	16.8	18.4	22.0
BZX84C27	WS	Y10	27	25.1	28.9	80	2.0	300	0.5	0.05	18.9	21.4	25.3
BZX84C30	WT	Y11	30	28.0	32.0	80	2.0	300	0.5	0.05	21.0	24.4	29.4
BZX84C33	WU	Y12	33	31.0	35.0	80	2.0	325	0.5	0.05	23.1	27.4	33.4
BZX84C36	WW	Y13	36	34.0	38.0	90	2.0	350	0.5	0.05	25.2	30.4	37.4
BZX84C39	WX	Y14	39	37.0	41.0	130	2.0	350	0.5	0.05	27.3	33.4	41.2
BZX84C43	WY	Y15	43	40.0	46.0	150	2.0	375	0.5	0.05	30.1	37.6	46.6
BZX84C47	WZ	Y16	47	44.0	50.0	170	2.0	375	0.5	0.05	32.9	42.0	51.8
BZX84C51	XA	Y17	51	48.0	54.0	180	2.0	400	0.5	0.05	35.7	46.6	57.2

- Note: 1. Type numbers listed have standard tolerance on the nominal zener voltage of ±5%.  
 2. TW: Marking code for Taiwan plant. CN: Marking code for China plant.  
 3. Measured with pulse test current I<sub>Z</sub> at ambient temperature 25°C.  
 4. f = 1KHz

## MARKING INFORMATION

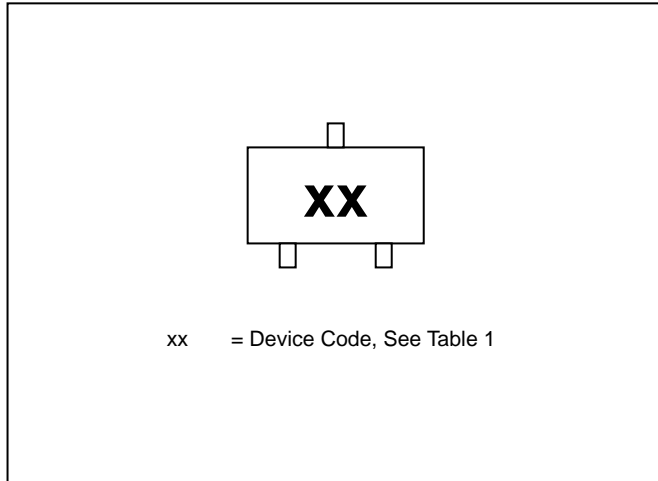

## RECOMMENDED FOOTPRINT

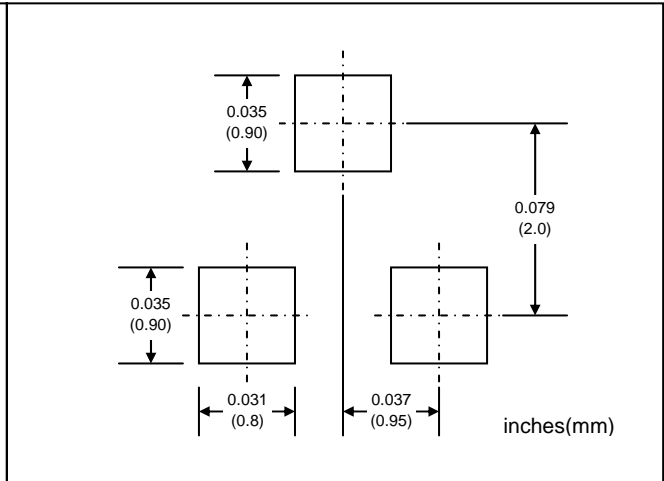

## PACKAGING INFORMATION

### TAPE & REEL

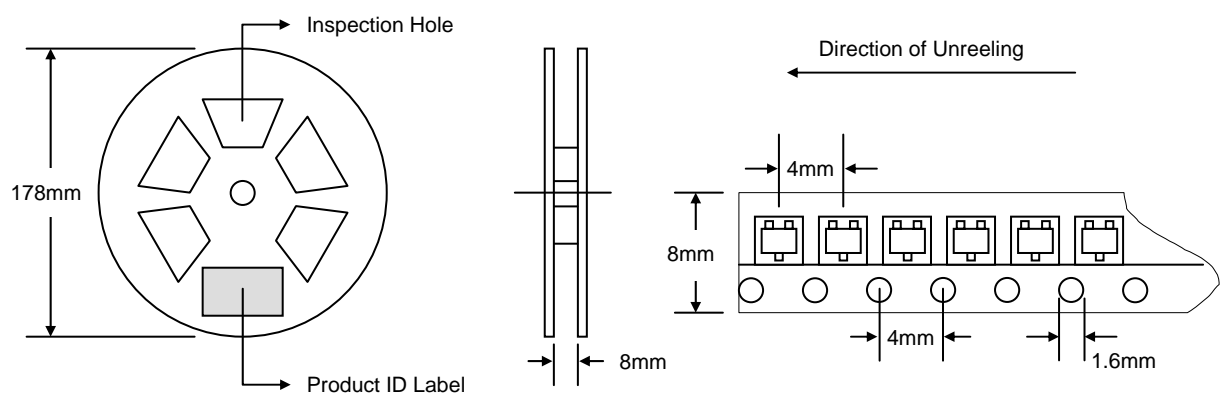

Reel Diameter (mm)	Quantity (PCS)	Inner Box Size L x W x H (mm)	Quantity (PCS)	Carton Size L x W x H (mm)	Quantity (PCS)	Approx. Gross Weight (KG)
178	3,000	187 x 187 x 65	15,000	390 x 240 x 420	150,000	10.0

**Note:** 1. Anti-static plastic reel, white, water clear or blue color. Inspection hole might be varied in different alignment.  
2. Components are packed in accordance with EIA standard 481-1 and 481-2.

## ORDERING INFORMATION

Product No.	Package Type	Shipping Quantity
BZX84Cxx-T1	SOT-23	3000/Tape & Reel

1. Shipping quantity given is for minimum packing quantity only. For minimum order quantity, please consult the Sales Department.
2. **To order RoHS / Lead Free version (with Lead Free finish), add "-LF" suffix to part number above. For example, BZX84C2V4-T1-LF.**

WON-TOP ELECTRONICS and  are registered trademarks of Won-Top Electronics Co., Ltd (WTE). WTE has checked all information carefully and believes it to be correct and accurate. However, WTE cannot assume any responsibility for inaccuracies. Furthermore, this information does not give the purchaser of semiconductor devices any license under patent rights to manufacturer. WTE reserves the right to change any or all information herein without further notice.

**WARNING:** DO NOT USE IN LIFE SUPPORT EQUIPMENT. WTE power semiconductor products are not authorized for use as critical components in life support devices or systems without the express written approval.

**Won-Top Electronics Co., Ltd.**  
No. 44 Yu Kang North 3rd Road,  
Chine Chen Dist., Kaohsiung 806, Taiwan  
**Phone:** 886-7-822-5408 or 886-7-822-5410  
**Fax:** 886-7-822-5417  
**Email:** sales@wontop.com  
**Internet:** <http://www.wontop.com>

*We power your everyday.*