

THIS DRAWING IS UNPUBLISHED. RELEASED FOR PUBLICATION 20
 © COPYRIGHT 20 BY TYCO ELECTRONICS CORPORATION. ALL RIGHTS RESERVED.

LOC		DIST		REVISIONS			
P	LTR	DESCRIPTION	DATE	DWN	APVD		
-	-	AI	REVISED PER ECO-09-010030	23APR2009	SS	MS	

- 1. CABLE DIAMETER RANGE: $\varnothing 4.5 - \varnothing 6.9$
- 2. 36.9 IN-LBS TORQUE RECOMMENDED FOR DOME NUT.
- 3. INTERFACIAL SEAL IS SECURED TO HOUSING WITH ADHESIVE.

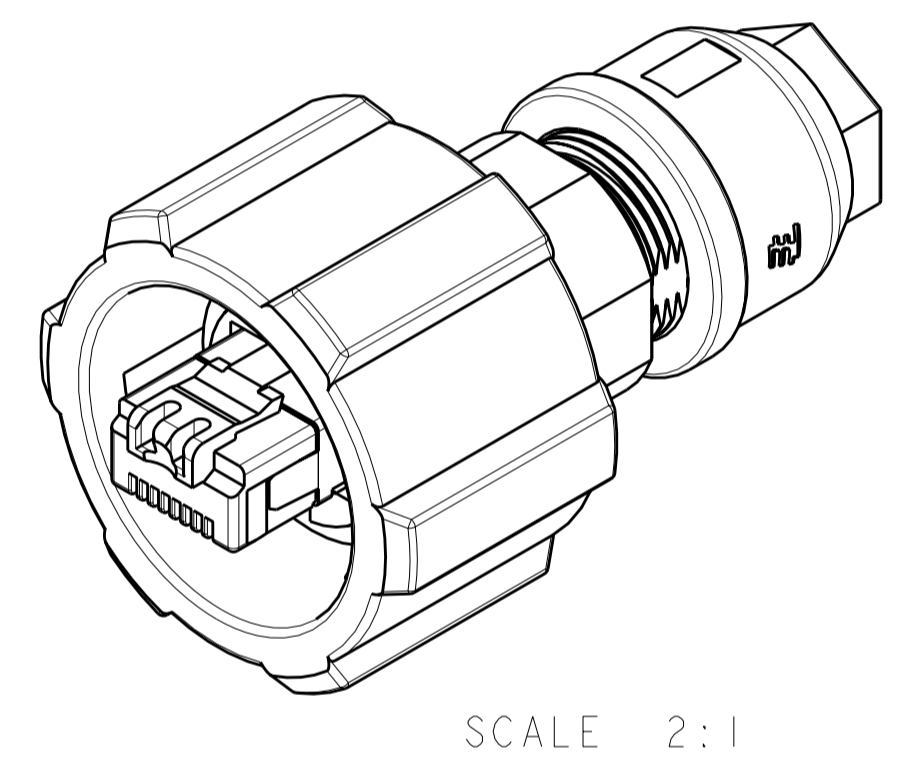
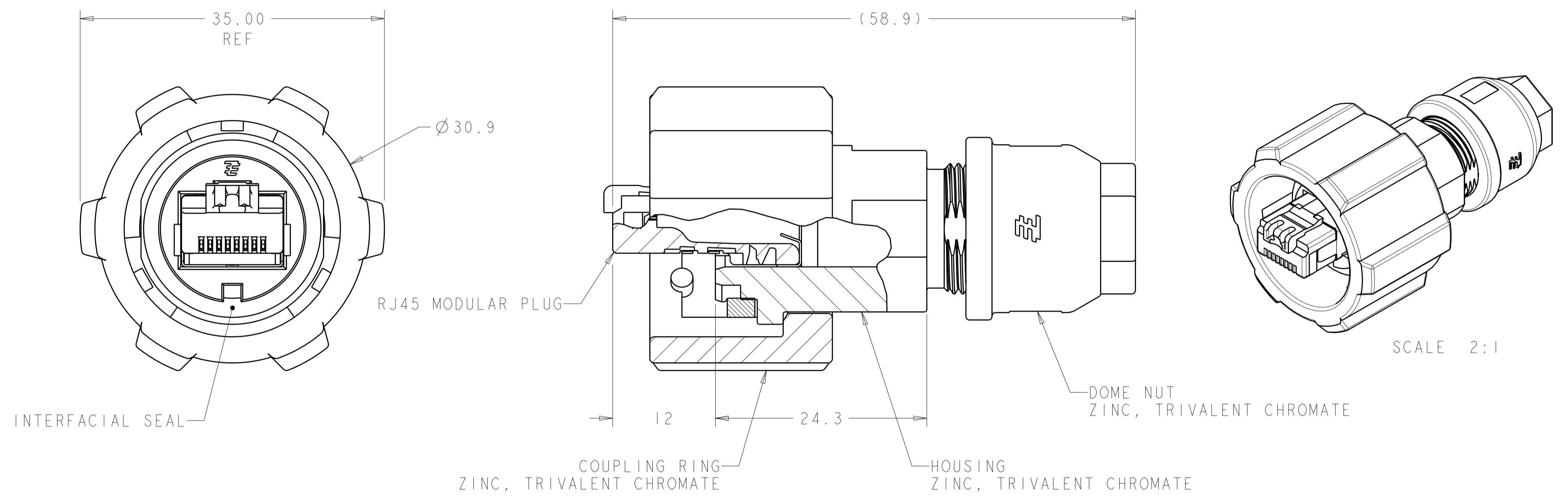

SOLID WIRE	2008614-2
STRANDED WIRE	2008614-1
WIRE TYPE	PART NUMBER

<small>THIS DRAWING IS A CONTROLLED DOCUMENT FOR TYCO ELECTRONICS CORPORATION. IT IS SUBJECT TO CHANGE AND THE CONTROLLING ENGINEERING ORGANIZATION SHOULD BE CONTACTED FOR THE LATEST REVISION.</small>		DWN S. WELDON 26MAR2008 CHK C. HERTZLER 26MAR2008 APVD C. HERTZLER 26MAR2008	Tyco Electronics Tyco Electronics Harrisburg, PA 17105-3608
DIMENSIONS: mm 	TOLERANCES UNLESS OTHERWISE SPECIFIED: 0 PLC ±1.0 1 PLC ±0.2 2 PLC ±0.10 3 PLC ±0.000 4 PLC ±0.0000 ANGLES ±1° FINISH	PRODUCT SPEC 108-2198 APPLICATION SPEC 114-13136 WEIGHT - CUSTOMER DRAWING	NAME PLUG KIT, SHIELDED, INDUSTRIAL CIRCULAR ETHERNET CONNECTOR SIZE A2 CAGE CODE 00779 DRAWING NO. C-2008614 RESTRICTED TO - SCALE 3:1 SHEET OF REV.

www.DataSheet4U.com