

Doc. Version	Draft B
Total Page	20
Date	2006/05/11

Product Specification

7.0" COLOR TFT-LCD MODULE

MODEL NAME: C070VW01 V0

- <◆>Draft Version
- < >Preliminary Specification
- < >Final Specification

© 2006 AU Optronics
All Rights Reserved
DO NOT COPY

Record of Revision

Version	Revise Date	Page	Content
Draft A	2005/11/25		First draft.
Draft B	2006/05/11	4	C. - Updated weight
		5	D.1.a - Updated connector type and part number
		7	D.2 - Updated VCOM
		8	D.3.c – Updated CCFL voltage and current
		8	D.3.a – Updated AVDD, VCOM & input reference voltage
		8	D.3.C – Updated Lamp Start Voltage at -30°C
		9	Note 6 – Updated IL
		13	E & note 1 – Updated IL
		13	E – Added Response Time Max.
		13	Note 2 – Updated testing condition
		14	Note 5 – Updated definition of white and black data
		17	Updated back view outline drawing
		19	I.1 – Updated Typical Application Circuit
			I.2 – Updated Power On/Off Sequence

Contents

A. Summary	4
B. Features	4
C. Physical Specifications	4
D. Electrical Specifications	5
1. Pin Assignment.....	5
2. Absolute Maximum Ratings.....	7
3. Electrical Characteristics	7
E. Optical specifications.....	13
F. Reliability Test Items	14
G. Outline Dimension	16
H. Packing Form.....	18
I. Application Notes.....	18
1. Typical Application Circuit.....	19
2. Power On/Off Sequence.....	20

Internal Use Only

A. Summary

The AUO Color amorphous silicon Thin Film Transistor LCD module is an active matrix Liquid Crystal Display produced by making the most of AUO's expertise in Flat Panel Display technologies having a 16:9 aspect ratio which main application is Navigation of automotive field.

B. Features

- I 7" panel with 16:9 aspect ratio
- I WVGA resolution (800x480) with stripe RGB pixel design
- I 600nits high brightness with dual CCFL
- I High contrast by Super Wide View technology
- I TN-normally white mode

C. Physical Specifications

NO.	Item	Unit	Specification	Remark
1	Display Resolution	dot	800RGB(H)×480(V)	
2	Active Area	mm	152.40(H)×91.44(V)	
3	Screen Size	inch	7.0(Diagonal)	
4	Pixel Pitch	mm	0.1905(H)×0.1905(V)	
5	Color Configuration	--	R. G. B. Stripe	Note 1
6	Color Depth	--	262K Colors	Note 2
7	Overall Dimension	mm	165(H) × 104(V) × 12.7(T)	Note 3
8	Weight	g	240	
9	Panel surface treatment	--	AG(25% haze) & with SWV film	
10	Display Mode	--	Normally White	
11	Backlight Unit	--	Dual CCFL	

Note 1: Below figure shows the dot stripe arrangement.

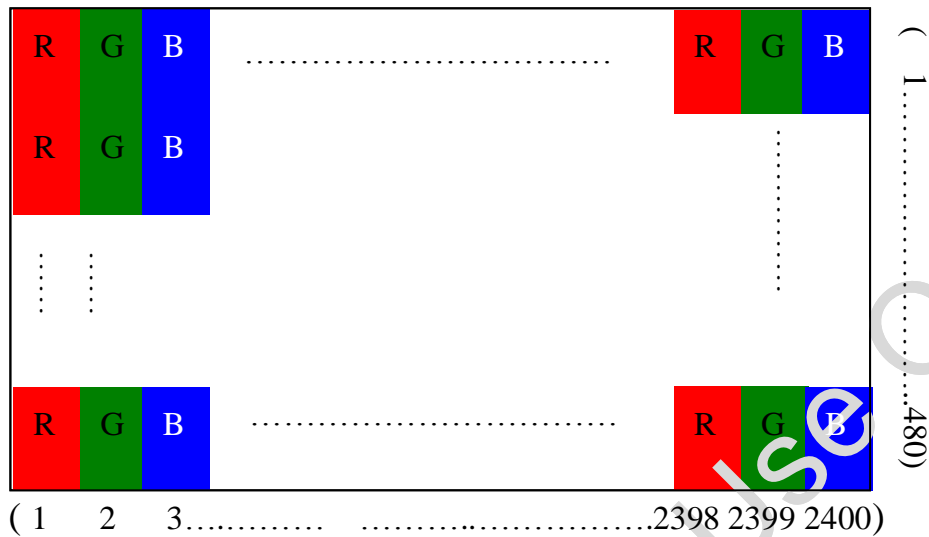

Note 2: The 262K color display depends on 6-bit data signal input.

Note 3: Not including the backlight cable and screw height. Refer to Section G, "Outline Dimension – Back View" for further information.

D. Electrical Specifications

1. Pin Assignment

a. TFT-LCD panel driving section

Connector type: 62684-501100ALF (FCI CONN 50PIN) or compatible

Pin No	Symbol	I/O	Function
1	GND	P	Ground for gate driver
2	VCC	P	Digital voltage for gate driver
3	VGL	P	TFT low voltage
4	VGH	P	TFT high voltage
5	STVL	I/O	Start pulse signal input/output (Vertical)
6	STVR	I/O	Start pulse signal input/output (Vertical)
7	CKV	I	CLK (Vertical)
8	U/D	I	Up or Down display control
9	OEV	I	Output enable
10	VCOM	I	VCOM voltage
11	DIO1	I/O	Start pulse signal input/output (Horizontal)

12	AVDD	P	Analog voltage for source driver
13	AVSS	P	Analog ground for source driver
14	GND	P	Digital ground for source driver
15	VCC (DVDD)	P	Digital voltage for source driver
16	EDGSL	I	Select raising edge or raising/falling edge
17	CLK	I	Sample CLK
18	SHL(R/L)	I	Right or Left display control
19	R0	I	Red data
20	R1	I	Red data
21	R2	I	Red data
22	R3	I	Red data
23	R4	I	Red data
24	R5	I	Red data
25	G0	I	Green Data
26	G1	I	Green Data
27	G2	I	Green Data
28	G3	I	Green Data
29	G4	I	Green Data
30	G5	I	Green Data
31	V1	I	Reference voltage
32	V2	I	Reference voltage
33	V3	I	Reference voltage
34	V4	I	Reference voltage
35	V5	I	Reference voltage
36	V6	I	Reference voltage
37	V7	I	Reference voltage
38	V8	I	Reference voltage
39	V9	I	Reference voltage
40	V10	I	Reference voltage
41	B0	I	Blue Data
42	B1	I	Blue Data
43	B2	I	Blue Data
44	B3	I	Blue Data
45	B4	I	Blue Data
46	B5	I	Blue Data

47	LD (OEH)	I	Latch and switch data to output (need these if TCON embedded?)
48	REV	I	Control data are inverted or not
49	POL	I	Polarity selection
50	DIO2	I/O	Start pulse signal input/output (Horizontal)

I: Input pin; O: Output pin; P: Power pin

b. Backlight driving section

Connector type: JST BHR-04S-1 or compatible

No.	Symbol	I/O	Description
1	HI	I	Power supply for backlight unit (High voltage)
2	GND	-	Ground for backlight unit
3	GND	-	Ground for backlight unit
4	HI	I	Power supply for backlight unit (High voltage)

2. Absolute Maximum Ratings

Items	Symbol	Product Specification			Unit
		Min.	Typ.	Max.	
Power Voltage	VCC	-0.3		5	V
	AVDD	-0.5		12	V
	VGH	-0.3		18	V
	VGL	-15		0.3	V
	VGH-VGL			33	V
Input Signal Voltage	Vi	-0.3		Vcc+0.3	V
	Vref(V1~V5)	0.4AVDD		AVDD+0.3	V
	Vref(V6~V10)	-0.3		0.6AVDD	V
	VCOM	4.0		4.4	V
Operating Temperature	Topa	-30		85	°C
Storage Temperature	Tstg	-40		95	°C

3. Electrical Characteristics

a. Typical operating conditions

Items	Symbol	Product Specification			Unit
		Min.	Typ.	Max.	

Power Voltage	VCC	3.0	3.3	3.6	V
	AVDD	9.7	9.8	9.9	V
	VGH	14.0	15.0	16.0	V
	VCOM	4.0	4.2	4.4	V
	VGL	-6.5	-7	-7.5	V
Input Reference Voltage	V1~V5	0.4AVDD	—	AVDD-0.1	V
	V6~V10	0.1	—	0.6AVDD	V
Input H/L level Voltage	VIH	0.8VCC	—	VCC	V
	VIL	0	—	0.2VCC	V

Note: The panel is designed to prevent the current leakage for the best display performance. If shorter discharge time is desired when system power off, then extra discharge circuit may be required at customer's side.

b. Current Consumption

Parameter	Symbol	Condition	Min.	Typ.	Max.	Unit
Current For Driver	IGH	VGH=15V		100	150	uA
	IGL	VGL=-7V		-100	-150	uA
	ICC	VCC=3.3V		3.5	5	mA
	IDD	AVDD=9.8V		20	30	mA

c. CCFL Backlight driving condition

Parameter	Symbol	Condition	Min.	Typ.	Max.	Unit
Voltage	VL		558	620	682	Vrms
Current	IL			4.5		mA
Frequency	FL			60	80	KHz
		T=25°C		890	1,100	Vrms
		T=0°C		1,160	1,440	Vrms
Lamp Start Voltage	Vs	T=-30°C		1200	1500	Vrms
Discharge Stabilization Time	Ts				3	min
Discharge Time lag	Td	Note 5			1	sec
Lamp life time		Note 6	10,000	-		Hr

Note 1: Panel surface temperature should be kept less than content of "D.2. Absolute maximum ratings".

Note 2: The lamp frequency should be selected as different as possible from display horizontal synchronous signal to avoid interference.

Note 3: Values of "Lamp Voltage", "Lamp power consumption" and "Starting voltage" are

defined on condition of the LCD module derived by NF[AS-114B] circuit which measured from connectors of product(as below figure). However this isn't the values that we can assure stability of starting lamp on condition that the module is installed in your set.

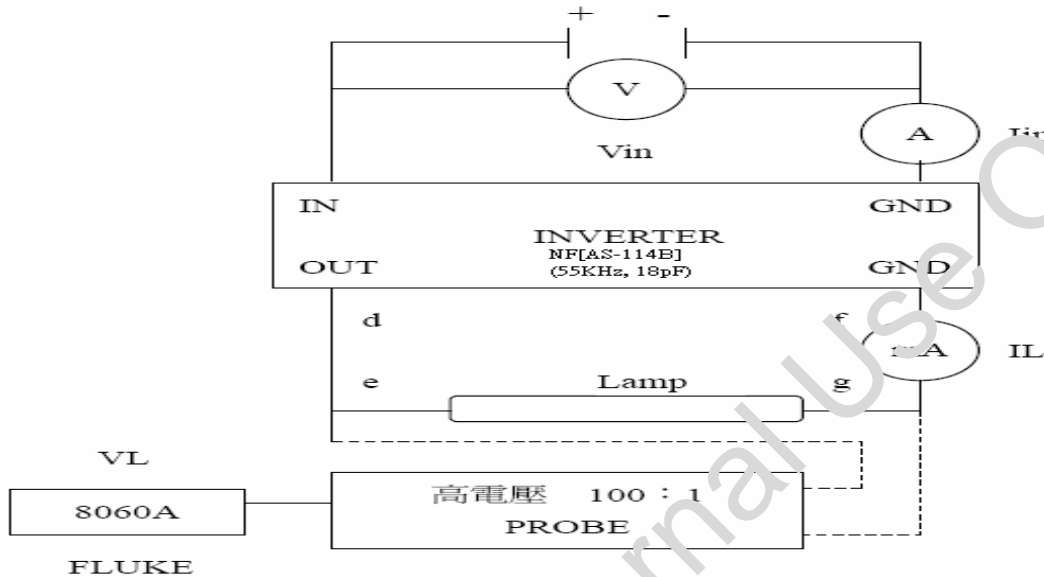

Note 4: The "MAX" of "Starting voltage" means the minimum voltage to light normally in the LCD module. The voltage should be supplied continually for 1 minute at least.

Note 5: "Discharge Time Lag" is the time needed to start discharge when the over 1500Vrms voltage is continuously applied to both end of the lamp. Before testing, the lamp is left in the dark room (ambient temperature: 25+/- 2oC, ambient luminance: less than 0.1lux) for 24Hrs after lightened for 1 minute at lated lamp current.

Note 6: The "Lamp life time" is defined as the time for the module brightness to decrease to 50% of original at Ta=25°C, IL=4.5mA

d. AC Timing Conditions

Characteristics (VCC=3.3V, AVDD=9.8V, AVSS=GND=0V, TA=25°C)

Parameter	Symbol	Min.	Typ.	Max.	Unit
CLK frequency	Fclk		40	42	MHz
CLK pulse width	TCW	8			ns
Data set-up time	Tsu	4			ns
Data hold time	Thd	2			ns
Propagation delay of DIO2/1	Tphl	6	10	15	ns
Time that the last data to LD	Tld	1			Tcw

Pulse width of LD	Twld	2			Tcw
Time that LD to DIO1/2	Tlds	5			Tcw
POL set-up time	Tpsu	6			ns
POL hold time	Tphd	6			ns
OEV pulse width	TOEV		12		Tcw
CKV pulse width	TCKV	16	28	40	Tcw
Horizontal display start	TSH		0		Tcw/3
Horizontal display timing range	TDH		800		Tcw/3
STV setup time	TSUV	400			ns
STV hold time	THDV	400			ns
STV pulse width	TSTV			1	TDH
Horizontal lines per field	TV	512	525	610	TDH
Vertical display start	TSV		3		TDH
Vertical display timing range	TDV		480		TDH

e. Timing Diagrams

■ Timing Diagram 1 (CHNSL="1" , Default)

<< EDGSL="0", Default >>

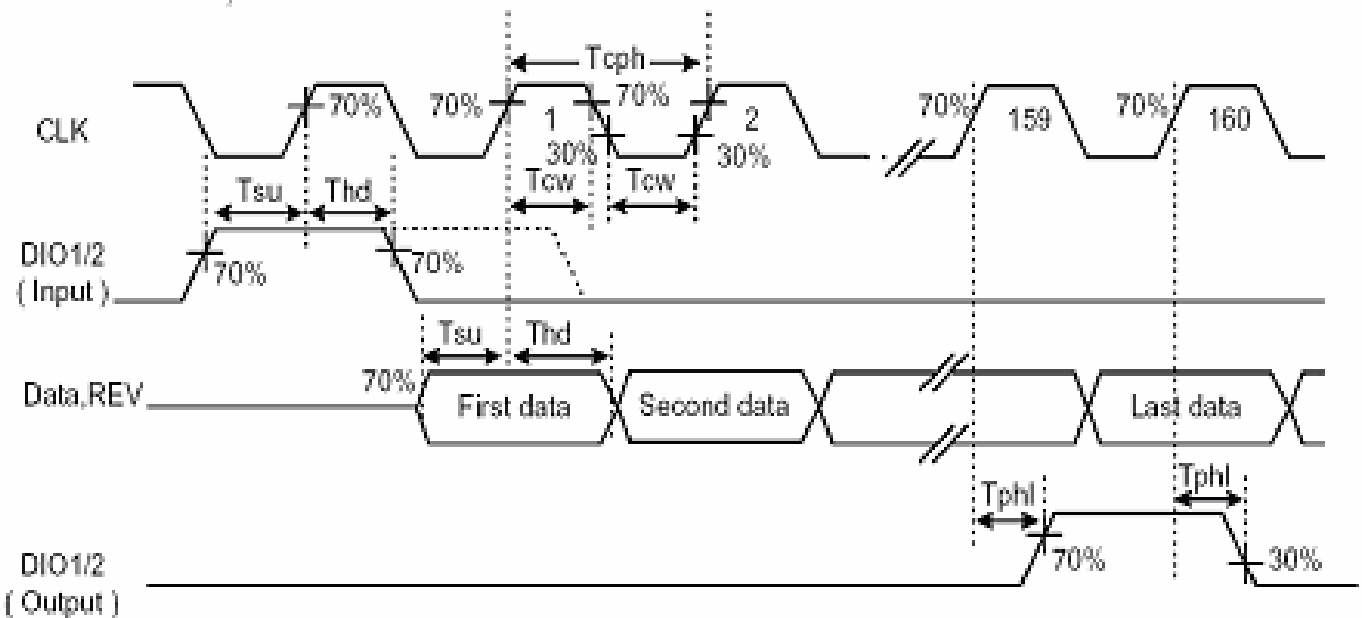

Figure 1. Operation Mode 1

<< EDGSL = "1" >>

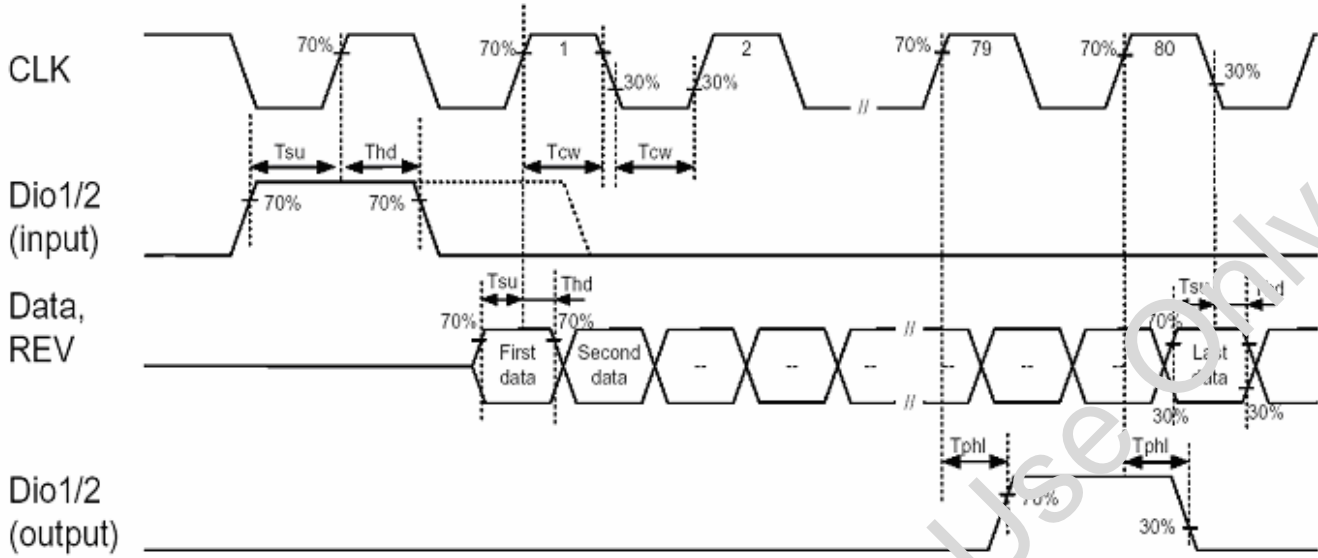

Figure 2. Operation Mode 1

■ Timing Diagram 2

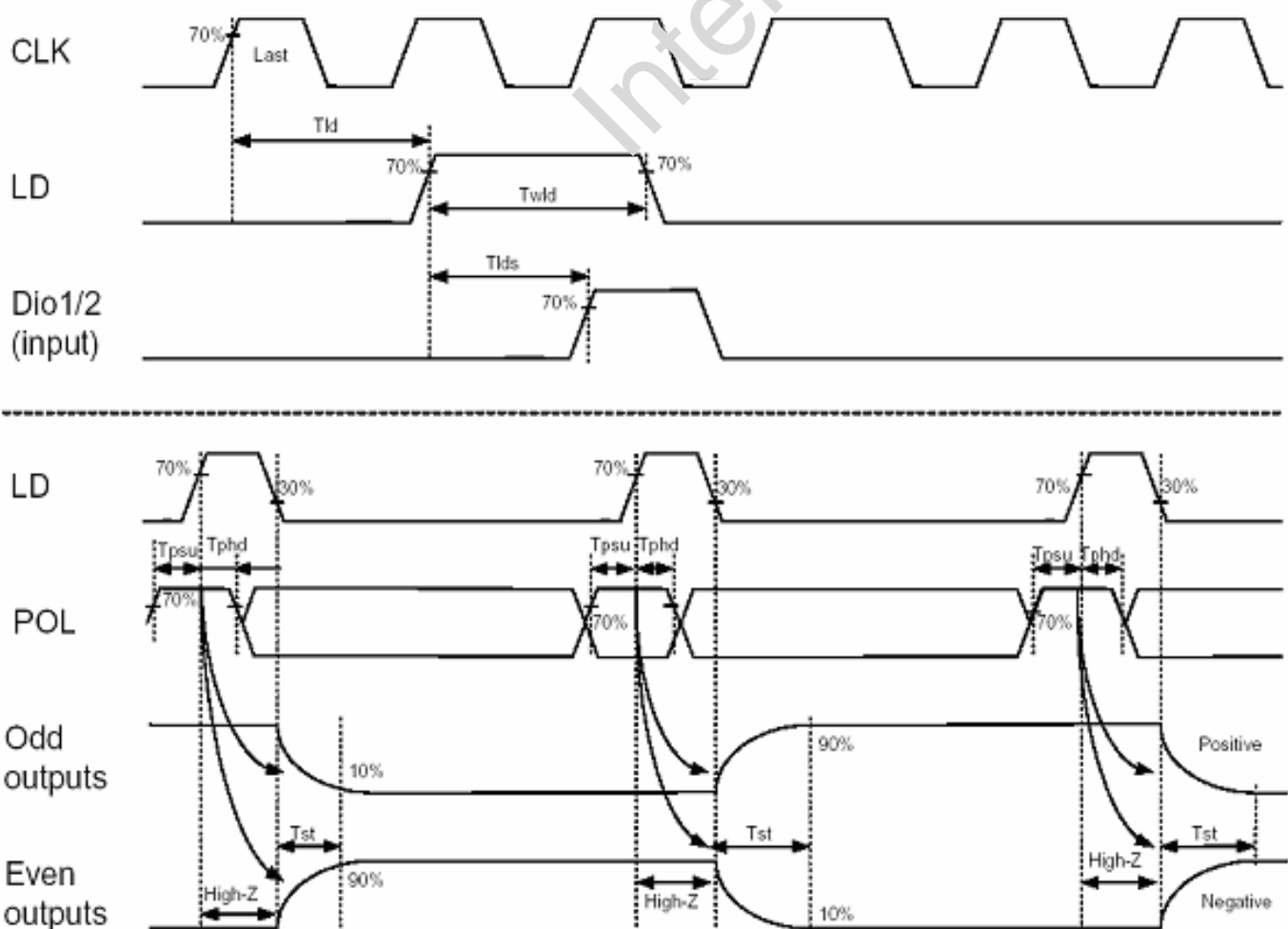

Figure 3. Horizontal Timing

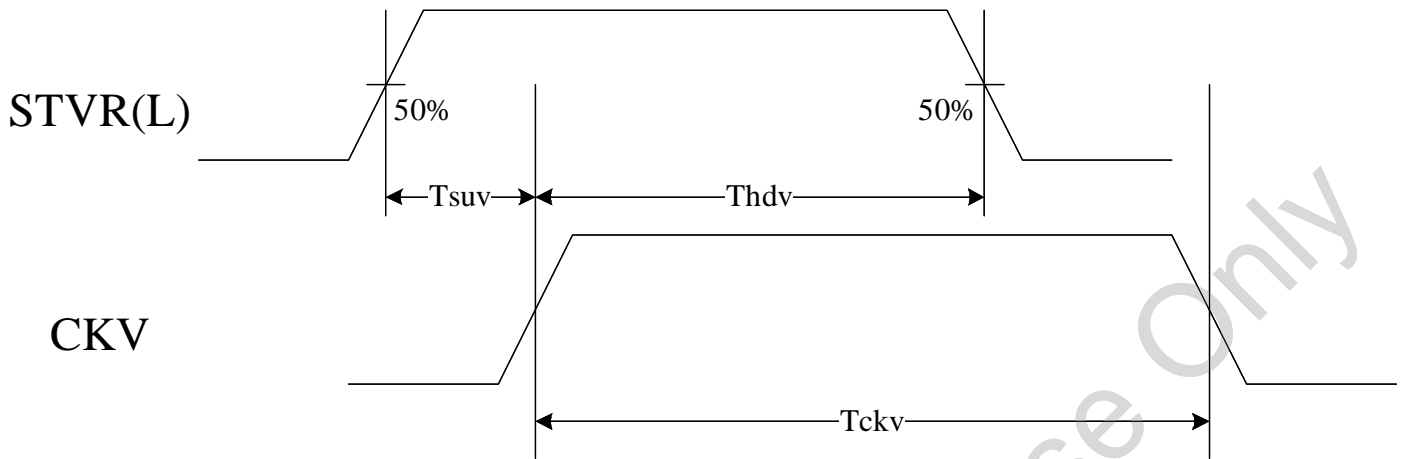

Figure 4. Vertical shift clock timing

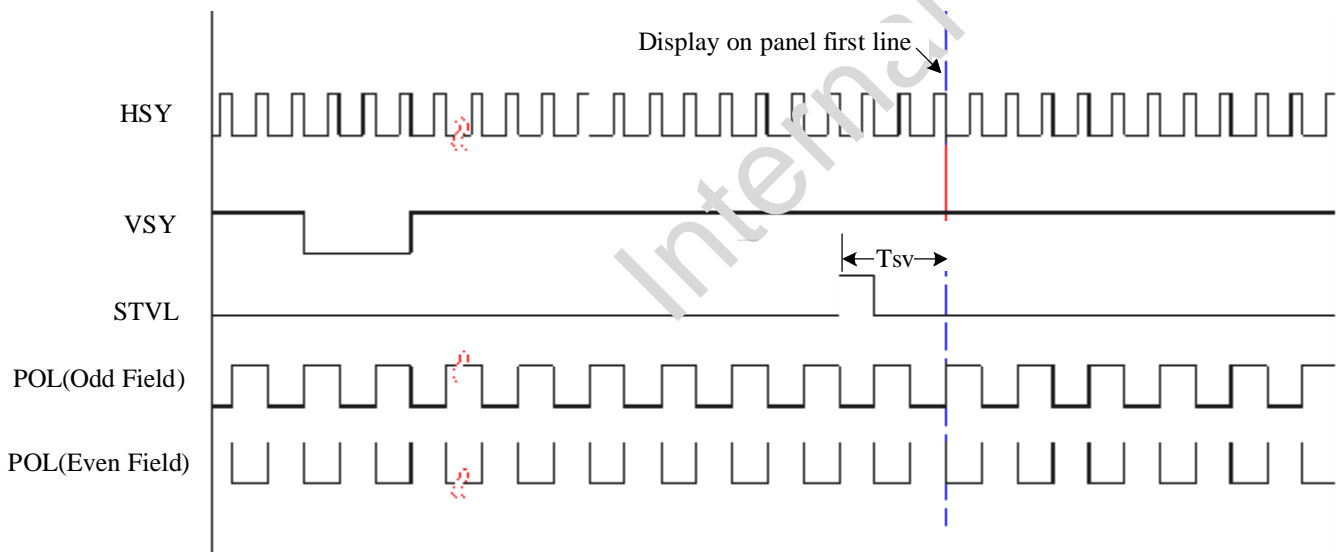

Figure 5. Vertical timing (from up to down)

E. Optical specifications

Item		Symbol	Condition	Min.	Typ.	Max.	Unit	Remark
Response time	Rise	Tr	$\theta=0^\circ$	-	6	10	ms	Note 3,5
	Fall	Tf		-	10	20	ms	
Contrast ratio		CR	At optimized Viewing angle	200	300	-		Note 4, 5
Viewing angle	Top		$CR \geq 10$	30	40	-	deg.	Note 5
	Bottom			50	60	-		
	Left			50	60	-		
	Right			50	60	-		
Viewing angle	Top		$CR \geq 5$	40	50	-	deg.	Note 5
	Bottom			60	70	-		
	Left			60	70	-		
	Right			60	70	-		
Brightness		Y_L	$I_L=4.5mA, 25^\circ C$	600	650	-	nit	Note 6
White chromaticity		x	$\theta=0^\circ$	0.26	0.31	0.36		Note 6
		y	$\theta=0^\circ$	0.28	0.33	0.38		

Note 1: Ambient temperature $=25^\circ C$, and lamp current $I_L = 4.5 \text{ mA}$. To be measured in the dark room.

Note 2: To be measured on the center area of panel with a viewing cone of 1° by Topcon luminance meter BM-5A, after 15 minutes operation.

Note 3: Definition of response time:

The response time is defined as the time interval between the 10% and 90% of amplitudes. The output signals of photo detector are measured when the input signals are changed from "black" to "white"(falling time) and from "white" to "black"(rising time).

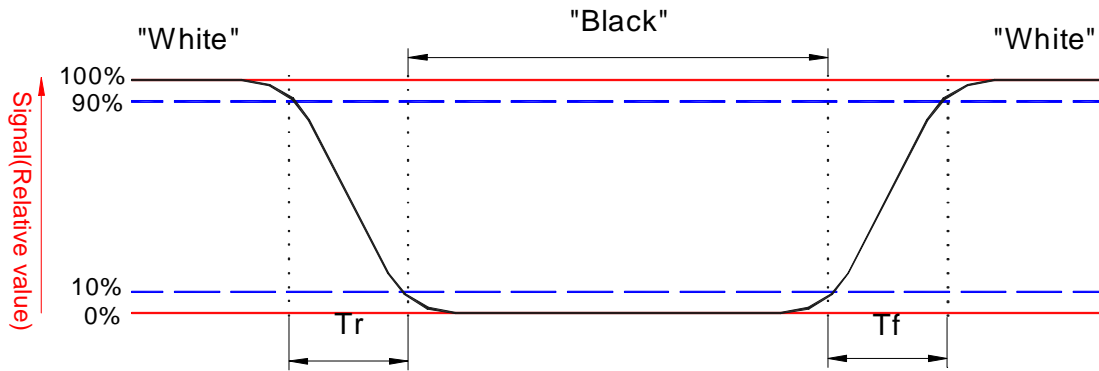

Note 4. Definition of contrast ratio:

Contrast ratio is calculated with the following formula.

$$\text{Contrast ratio (CR)} = \frac{\text{Photo detector output when LCD is at "White" state}}{\text{Photo detector output when LCD is at "Black" state}}$$

Note 5. Black reference voltage data =V1 or V10

White reference voltage data =V5 or V6

(For definition of V1, V5, V6 & V10, please refer to section I.1)

The 100% transmission is defined as the transmission of LCD panel when all the input terminals of module are electrically opened.

Note 6. Brightness and White Chromaticity are measured at the center area of the panel at white frame.

Note 7. For definition of viewing angle please refer to figure as below.

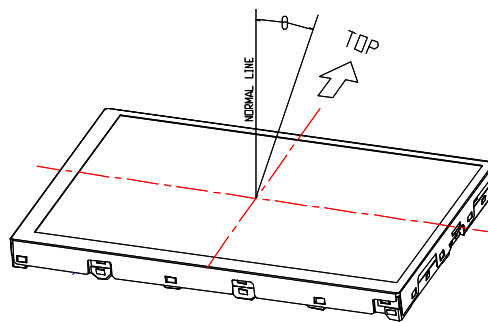

F. Reliability Test Items

No.	Test items	Conditions		Remark
1	High temperature storage	Ta= 95°C	240Hrs	
2	Low temperature storage	Ta= -40°C	240Hrs	
3	High temperature operation	Ta= 85°C	240Hrs	

4	Low temperature operation	Ta= -30°C	240Hrs	
5	High temperature and high	Ta= 60°C, 90% RH	240Hrs	Operation
6	Heat shock	-30°C ~85°C /200 cycles 1Hrs/cycle		Non-operation
7	Electrostatic discharge	±200V,200pF(0Ω), once for each terminal		Non-operation
8	Vibration	Frequency range	: 10~55Hz	
		Stroke	: 1.5mm	
		Sweep	: 10 ~ 55 ~ 10Hz	
		2 hours for each direction of X,Y,Z (6 hours for total)		
9	Mechanical shock	100G, 6ms, ±X,±Y,±Z 3 times for each direction		
10	Vibration (with carton)	Random vibration: 015G ² /Hz from 5~200Hz -6dB/octave from 200~500Hz		
11	Drop (with carton)	Height: 60cm 1 corner, 3 edges, 6 surfaces		

Note 1: Ta: Ambient temperature.

Note 2: In the standard conditions, no display function NG is allowed. All the cosmetic specification is judged before the reliability stress.

G. Outline Dimension

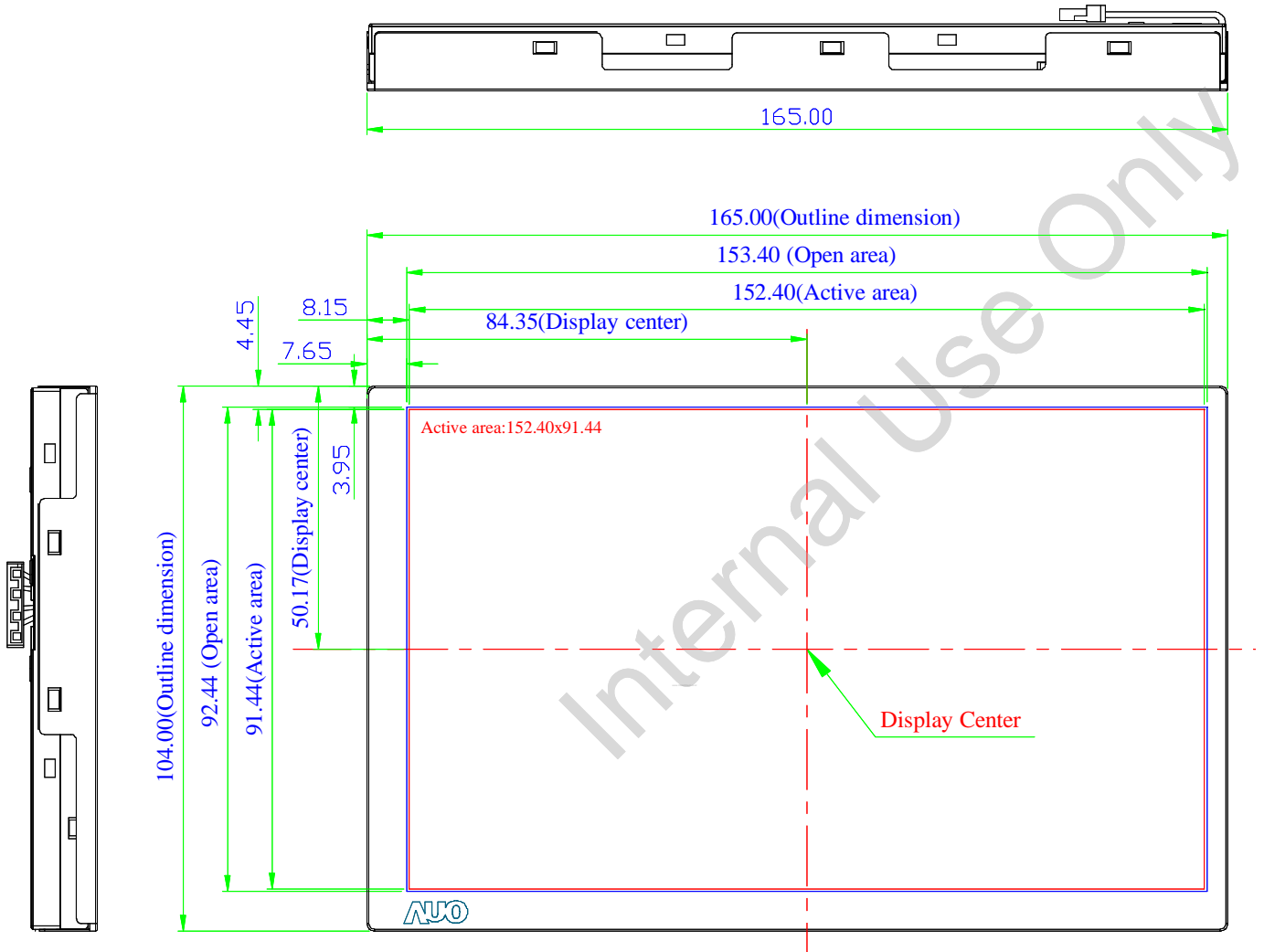

Figure 6. Front View

NOTES:

- 1.General tolerance is $\pm 0.3\text{mm}$.
- 2.Power Connector: JST BHR-04VS-1
- 3.Lamp connector Pin out: Pin 1 and Pin 4(High voltage/color: pink);
Pin 2 and Pin 3(GND/color: White) and Lamp #1: Pin 1, 2; Lamp #2: Pin 3, 4
- 4.Recommend using M3.0, pitch 0.4mm depth 3.0mm Max. screw to fix the module.
- 5.Recommend using depth 3.6mm Max. screw to fix the Control board.
- 6.Driving Connector: 62684-501100ALF (FCI CONN 50PIN)

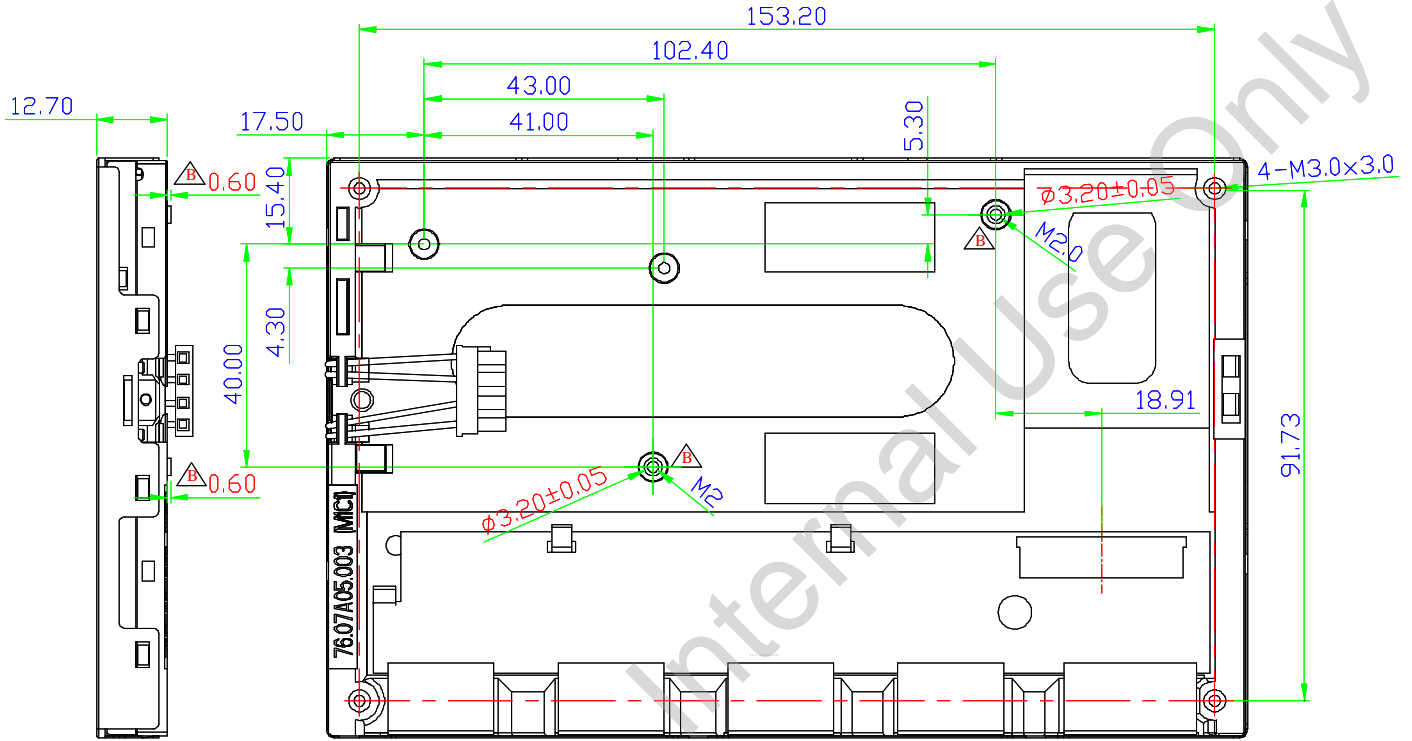
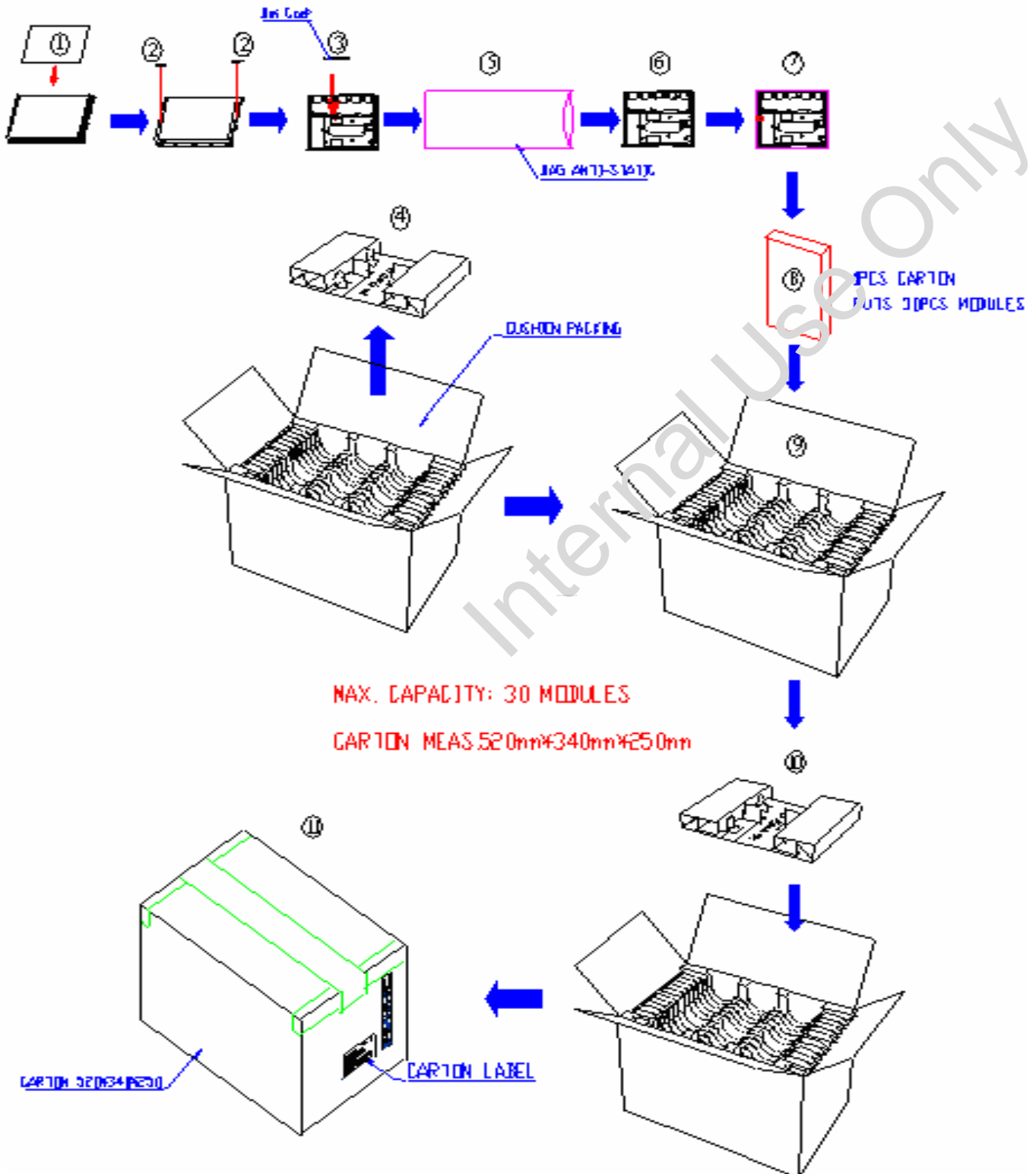

Figure 7. Back View

H. Packing Form



I. Application Notes

1. Typical Application Circuit

Gamma circuit: (When gamma value be setup at 2.2)

Gamma circuit:

	AVDD	9.80
00H	V1	9.70
10H	V2	8.08
20H	V3	7.56
30H	V4	7.16
3FH	V5	5.93
3FH	V6	4.33
30H	V7	2.88
20H	V8	2.42
10H	V9	1.80
00H	V10	0.10

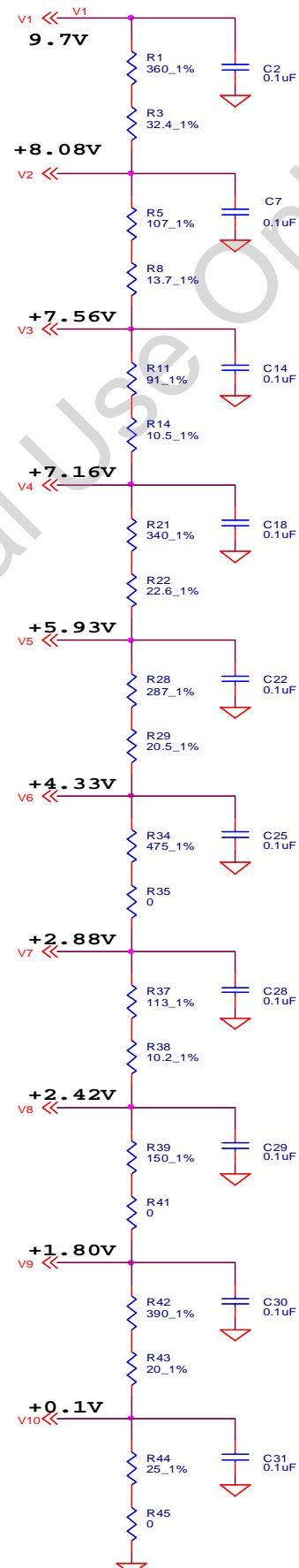

2. Power On/Off Sequence

* Power on/off Sequence *

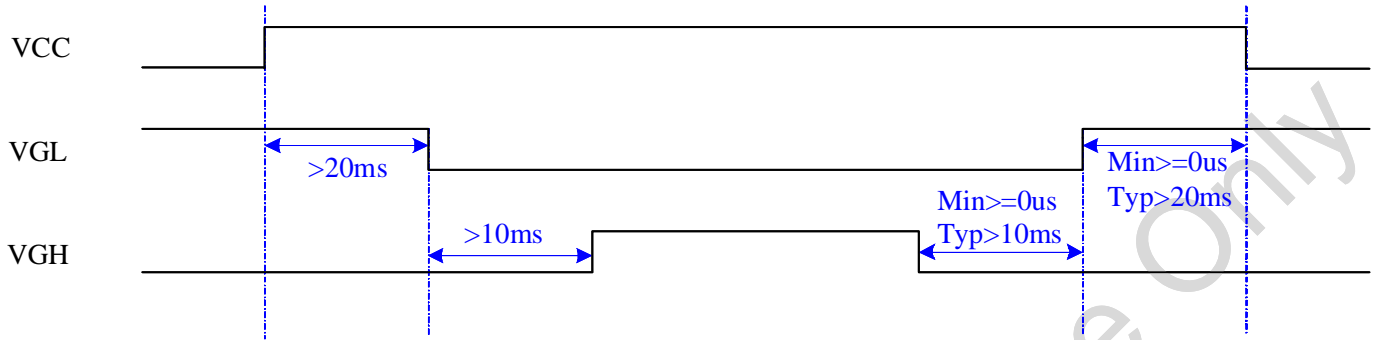

Internal Use Only