

C30659 Series – 900/1060/1550/1550E **Si and InGaAs APD Preamplifier Modules**

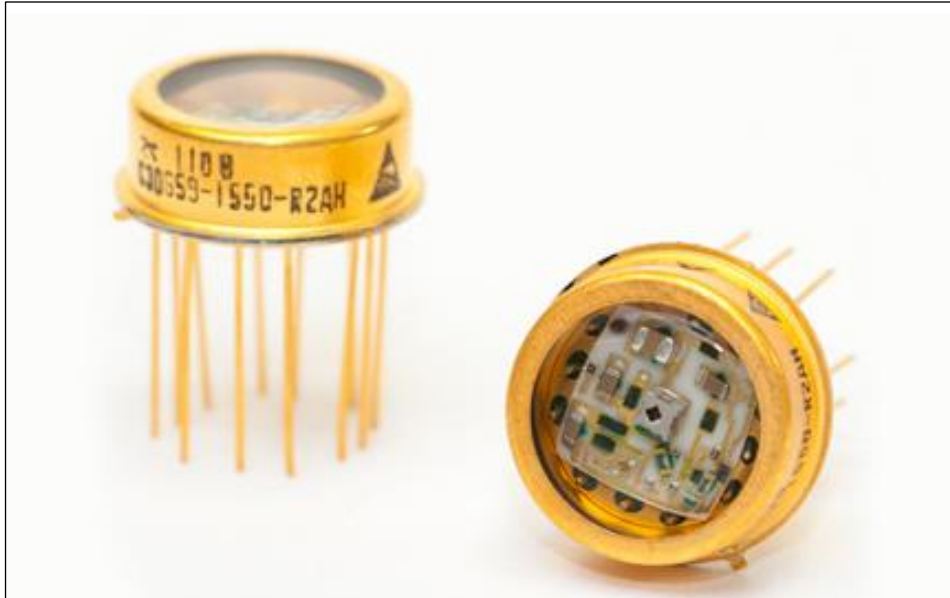

Key Features

- System bandwidths of 50 MHz and 200MHz
- Ultra low noise equivalent power (NEP)
- Spectral response range:
 - With Si APD: 400 to 1100 nm
 - With InGaAs APD: 1100 to 1700 nm
- Typical power consumption: 150 mW
- ± 5 V amplifier operating voltages
- 50 Ω AC load capability (AC-Coupled)
- Hermetically-sealed TO-8 package
- High reliability
- Fast overload recovery
- Pin-to-pin compatible with the C30950 Series
- Light entry angle, over 130°
- Model 1550E exhibits enhanced damage threshold
- RoHS-compliant

Excelitas' C30659-1550E InGaAs APD Preamplifier Modules exhibit enhanced damage threshold and greater resilience when exposed to higher optical power densities.

Excelitas Technologies' C30659 Series includes a Si or InGaAs Avalanche Photodiode (APD) with a hybrid preamplifier, in the same hermetically-sealed TO-8 package, to allow for ultra-low noise operation.

The Si APDs used in these devices are the same as used in Excelitas' C30817EH, C30902EH, C30954EH and C30956EH products, while the InGaAs APDs are used in the C30645EH and C30662EH products. These detectors provide very good response between 830 and 1550 nm and very fast rise- and fall-times at all wavelengths. The preamplifier section of the module uses a very low noise GaAs FET front end designed to operate at higher transimpedance than Excelitas' regular C30950 Series.

The C30659 is pin-to-pin compatible with the C30950 Series with a negative output. An emitter follower is used as an output buffer stage. To obtain the wideband characteristics, the output of these devices should be capacitively- or AC-coupled to a 50 Ω termination. The module must not be DC-coupled to loads of less than 2,000 Ohms. For field use, it is recommended that a temperature-compensated HV supply be employed to maintain a constant responsivity over temperature.

Excelitas' InGaAs C30659-1550E Preamplifier Modules, with 1550 nm peak response, are designed to exhibit higher damage thresholds, thus providing greater resilience when exposed to high optical power densities.

Customization of the C30659 Series of APD Preamplifier Modules is available to meet your specific design challenges; modifications include bandwidth and gain optimization, use of different APDs, FC-connectorized packaging.

Applications

- Range finding
- LIDAR
- Confocal microscopy

Si and InGaAs APD Preamplifier Modules

Table 1. Performance Specifications – C30659-900 Models (900 nm peak response Si APD)Test conditions: Case temperature = 22°C, $V_{amp} = \pm 5$ V, $HV = V_{op}$ (see Note 1), $R_L = 50 \Omega$ AC coupled

Detector Type	C30659-900-R8AH (C30817EH APD)			C30659-900-R5BH (C30902EH APD)			Units
	Min	Typical	Max	Min	Typical	Max	
Active diameter		0.8			0.5		mm
Active area		0.5			0.2		mm ²
Nominal field of view α (see Figure 8)		147			148		Degrees
Nominal field of view α' (see Figure 8)		151			151		Degrees
System bandwidth, f_{-3dB}	40	50		175	200		MHz
Bandwidth range		50			200		MHz
Temperature coefficient of V_{op} for constant gain		2.2			0.7		V/°C
V_{op} for specified responsivity	275	Note 1	435	180	Note 1	260	V
Temperature sensor sensitivity (Note 2)	-1.8	-2.1	-2.4	-1.8	-2.1	-2.4	mV/°C
Responsivity							
at 830 nm		2700			460		kV/W
at 900 nm		3000			400		kV/W
R_f (Internal feedback resistor)		82			12		k Ω
Noise equivalent power (NEP) (Note 3)							
Average from 100 kHz to f_{-3dB} , $\Delta f = 1.0$ Hz							
at 830 nm		14	17		35	55	fW/ $\sqrt{\text{Hz}}$
at 900 nm		12	15		40	65	fW/ $\sqrt{\text{Hz}}$
Output spectral noise voltage							
Averaged from 100 kHz to f_{-3dB}		35	45		15	25	nV/ $\sqrt{\text{Hz}}$
Output impedance	33	40	50	33	40	50	Ω
Rise time, t_r ($\lambda = 830$ and 900 nm) 10% to 90% points		7			2		ns
Fall time, t_f ($\lambda = 830$ and 900 nm) 90% to 10% points		7			2		ns
Recovery time after overload (Note 4)			150			150	ns
Output voltage swing (1 k Ω load) (Note 5)	2	3		2	3		V
Output voltage swing (50 Ω load) (Note 5)	0.7	0.9		0.7	0.9		V
DC output offset voltage	-1	0.25	1	-1	0.25	1	V
Positive supply current (V_+)		20	35		20	35	mA
Negative supply current (V_-)		10	20		10	20	mA

Notes:

1. A specific value of V_{op} is supplied with each device. The V_{op} value will be within the specified range.
2. $I_f = 0.1$ mA at 25°C.
3. NEP is calculated as the output spectral noise voltage divided by the typical responsivity.
4. 0 dBm with 250 ns pulses.
5. Pulsed operation.

Si and InGaAs APD Preamplifier Modules

Table 2. Performance Specifications – C30659-1060 Models (1060 nm optimized response Silicon APD)Test conditions: Case temperature = 22 °C, $V_{amp} = \pm 5$ V, $HV = V_{op}$ (see Note 1), $R_L = 50 \Omega$ AC coupled

Detector type	C30659-1060-3AH (C30956EH APD)			C30659-1060-R8BH (C30954EH APD)			Units
	Min	Typical	Max	Min	Typical	Max	
Active diameter		3.0			0.8		mm
Active area		7.1			0.5		mm ²
Nominal field of view α (see Figure 8)		136			149		Degrees
Nominal field of view α' (see Figure 8)		154			153		Degrees
System bandwidth, f_{-3dB}	40	50		175	200		MHz
Bandwidth range		50			200		MHz
Temperature coefficient of V_{op} for constant gain		2.2			2.2		V/°C
V_{op} for specified responsivity	275	Note 1	425	275	Note 1	425	V
Temperature sensor sensitivity (Note 2)	-1.8	-2.1	-2.4	-1.8	-2.1	-2.4	mV/°C
Responsivity							
at 900 nm		450			370		kV/W
at 1060 nm		280			200		kV/W
R_f (Internal feedback resistor)		22			12		k Ω
Noise equivalent power (NEP) (Note 3)							
Average from 100 kHz to f_{-3dB} , $\Delta f = 1.0$ Hz							
at 900 nm		55	90		55	80	fW/ $\sqrt{\text{Hz}}$
at 1060 nm		90	125		100	150	fW/ $\sqrt{\text{Hz}}$
Output spectral noise voltage							
Averaged from 100 kHz to f_{-3dB}		25	35		20	30	nV/ $\sqrt{\text{Hz}}$
Output impedance	33	40	50	33	40	50	Ω
Rise time, t_r ($\lambda = 900$ and 1060 nm) 10% to 90% points		7			2		ns
Fall time, t_f ($\lambda = 900$ and 1060 nm) 90% to 10% points		7			2		ns
Recovery time after overload (Note 4)			150			150	ns
Output voltage swing (1 k Ω load) (Note 5)	2	3		2	3		V
Output voltage swing (50 Ω load) (Note 5)	0.7	0.9		0.7	0.9		V
DC output offset voltage	-1	0.25	1	-1	0.25	1	V
Positive supply current (V_+)		20	35		20	35	mA
Negative supply current (V_-)		10	20		10	20	mA

Notes:

1. A specific value of V_{op} is supplied with each device. The V_{op} value will be within the specified range.
2. $I_f = 0.1$ mA at 25 °C.
3. NEP is calculated as the output spectral noise voltage divided by the typical responsivity.
4. 0 dBm with 250 ns pulses.
5. Pulsed operation.

C30659 Series – 900/1060/1550/1550E

Si and InGaAs APD Preamplifier Modules

Table 3. Performance Specifications – C30659-1550/1550E Models (1550 nm peak response InGaAs APD)
 Test conditions: Case temperature = 22 °C, $V_{amp} = \pm 5$ V, $HV = V_{op}$ (see Note 1), $R_L = 50 \Omega$ AC coupled

Detector type	C30659-1550-R2AH C30659-1550E-R2AH (C30662EH APD)			C30659-1550-R08BH C30659-1550E-R08BH (C30645EH APD)			Units
	Min	Typical	Max	Min	Typical	Max	
Parameter							
Active diameter		0.2			0.08		mm
Active area		0.03			0.005		mm ²
Nominal field of view α (see Figure 8)		145			145		Degrees
Nominal field of view α' (see Figure 8)		146			146		Degrees
System bandwidth, f_{-3dB}	40	50		175	200		MHz
Bandwidth range		50			200		MHz
Temperature coefficient of V_{op} for constant gain		0.2			0.2		V/°C
V_{op} for specified responsivity	40	Note 1	70	40	Note 1	70	V
Temperature sensor sensitivity (Note 2)	-1.8	-2.1	-2.4	-1.8	-2.1	-2.4	mV/°C
Responsivity							
at 1300 nm		300			80		kV/W
at 1550 nm		340			90		kV/W
R_f (Internal feedback resistor)		68			18		k Ω
Noise equivalent power (NEP) (Note 3)							
Average from 100 kHz to f_{-3dB} , $\Delta f = 1.0$ Hz							
at 1300 nm		150	180		250	375	fW/ \sqrt{Hz}
at 1550 nm		130	160		220	330	fW/ \sqrt{Hz}
Output spectral noise voltage							
Averaged from 100 kHz to f_{-3dB}		45	55		20	30	nV/ \sqrt{Hz}
Output impedance	33	40	50	33	40	50	Ω
Rise time, t_r ($\lambda = 1300$ and 1550 nm) 10% to 90% points		7			2		ns
Fall time, t_f ($\lambda = 1300$ and 1550 nm) 90% to 10% points		7			2		ns
Recovery time after overload (Note 4)			150			150	ns
Output voltage swing (1 k Ω load) (Note 5)	2	3		2	3		V
Output voltage swing (50 Ω load) (Note 5)	0.7	0.9		0.7	0.9		V
DC output offset voltage	-1	0.25	1	-1	0.25	1	V
Positive supply current (V_+)		20	35		20	35	mA
Negative supply current (V_-)		10	20		10	20	mA

Notes:

1. A specific value of V_{op} is supplied with each device. The V_{op} value will be within the specified range.
2. $I_f = 0.1$ mA at 25 °C.
3. NEP is calculated as the output spectral noise voltage divided by the typical responsivity.
4. 0 dBm with 250 ns pulses.
5. Pulsed operation.

Si and InGaAs APD Preamplifier Modules



Table 4. Absolute – Maximum Ratings, Limiting Values

Detector type	C30659-900-R8AH (Silicon APD)		C30659-900-R5BH (Silicon APD)		C30659-1060 Models (Silicon APD)		C30659-1550 Models (InGaAs APD)		C30659-1550E Models (InGaAs APD)		Units
	Min	Max	Min	Max	Min	Max	Min	Max	Min	Max	
Photodiode bias voltage (Note 1) at $T_A = +70^\circ\text{C}$ at $T_A = -40^\circ\text{C}$		600		350		600		100		100	V
		300		210		300		50		50	V
Incident radiant flux, Φ_M , (Note 2) average (Note 3) peak (Note 4) peak (Note 5)		0.1		0.1		0.1		2		2	mW
		50		50		50					mW
							4		1000		kW/cm ²
Case temperature storage, T_{stg} operating, T_A	-50	100	-50	100	-50	100	-50	100	-50	100	°C
	-40	70	-40	70	-40	70	-40	70	-40	70	°C
Preamplifier bias voltage	±4.5	±5.5	±4.5	±5.5	±4.5	±5.5	±4.5	±5.5	±4.5	±5.5	V

Notes:

1. The operating voltage (V_{op}) must remain below the breakdown voltage (V_{br}), these values are worst-case estimates.
2. As demonstrated in laboratory conditions.
3. Based on 0.5 W electrical power on the high voltage (HV) supply.
4. Test with 50 ns pulse width.
5. Tested at 1060 nm, 10 ns pulse width and 1 kHz pulse repetition rate.

Figure 1. Schematic Block Diagram – C30659 Series

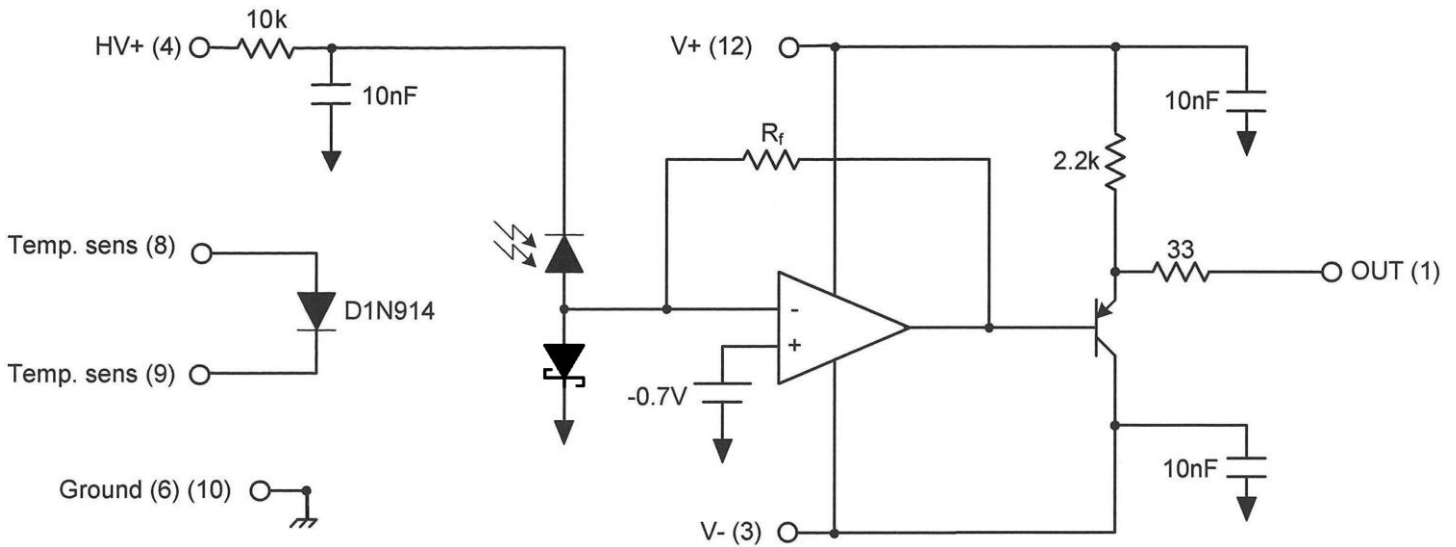

Figure 2. Typical Spectral Responsivity

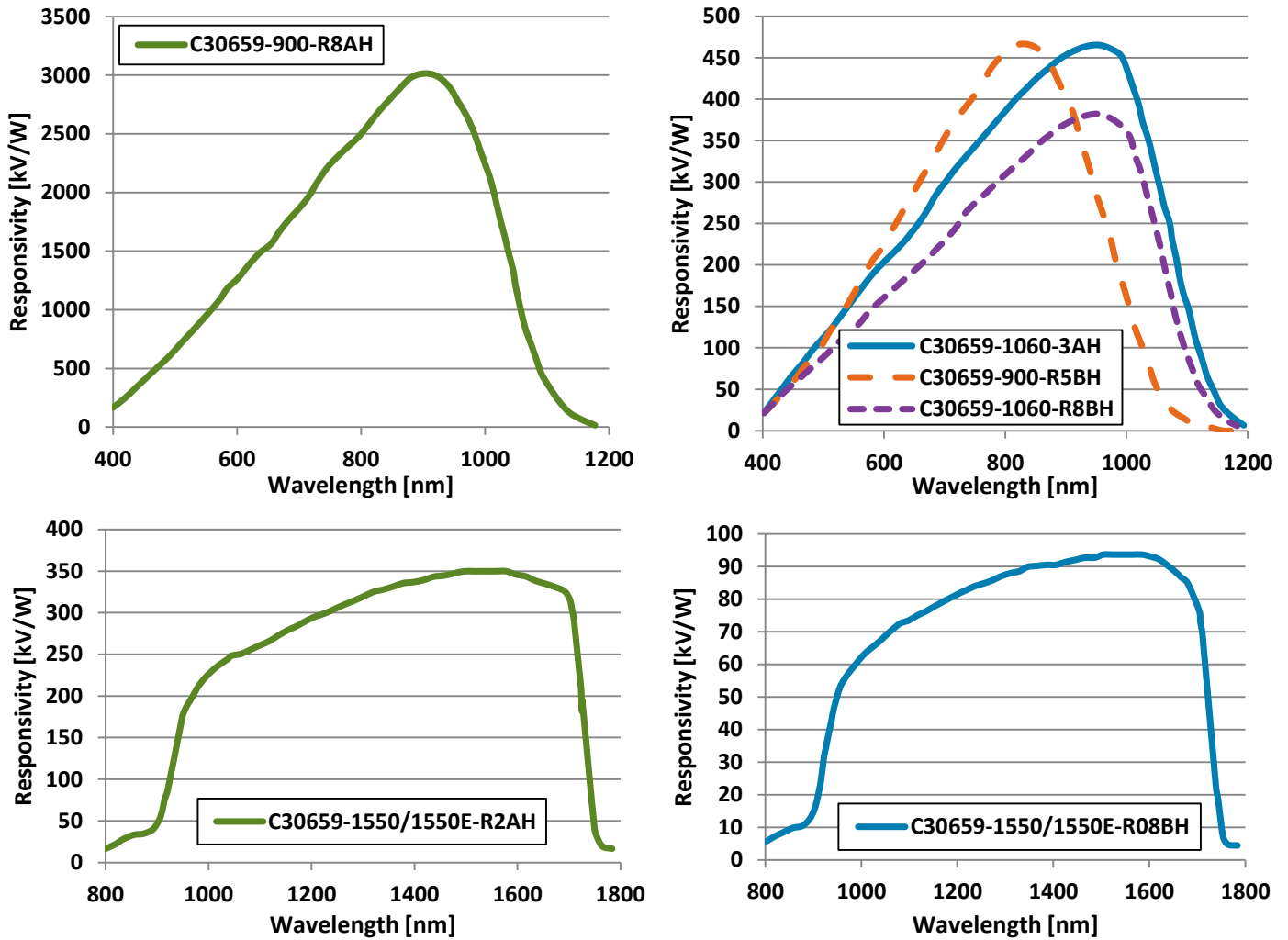
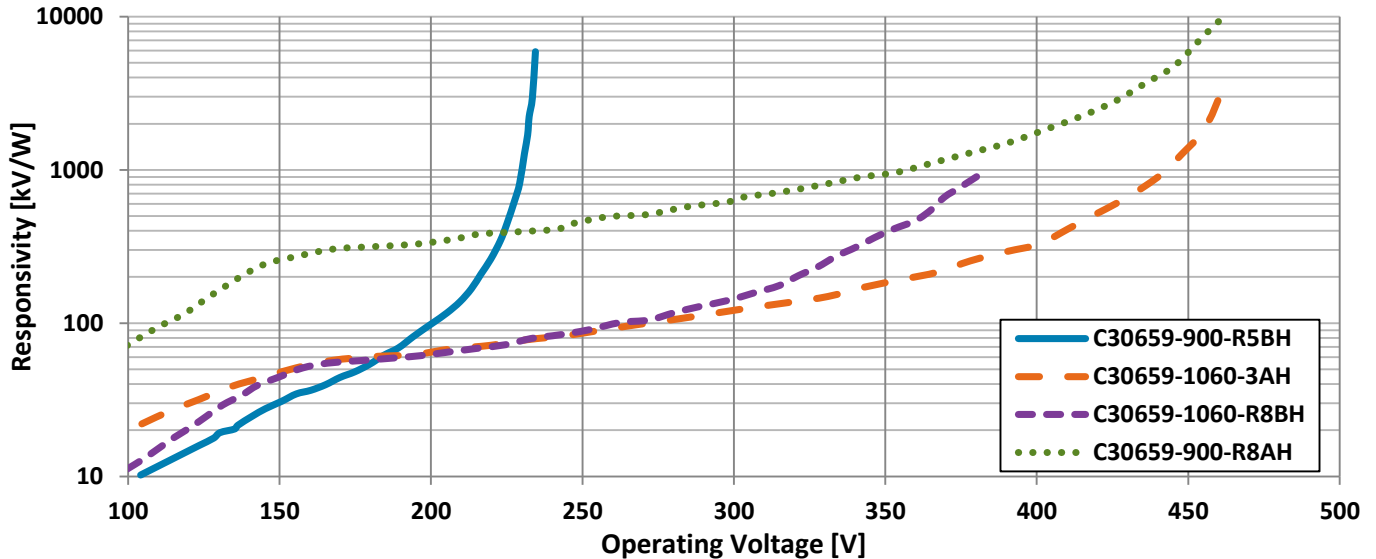

Figure 3. Typical Responsivity as a Function of Operating Voltage – C30659-(900/1060) Series



Si and InGaAs APD Preamplifier Modules

Figure 4. Typical Responsivity as a function of Operating Voltage – C30659-(1550/1550E) Series

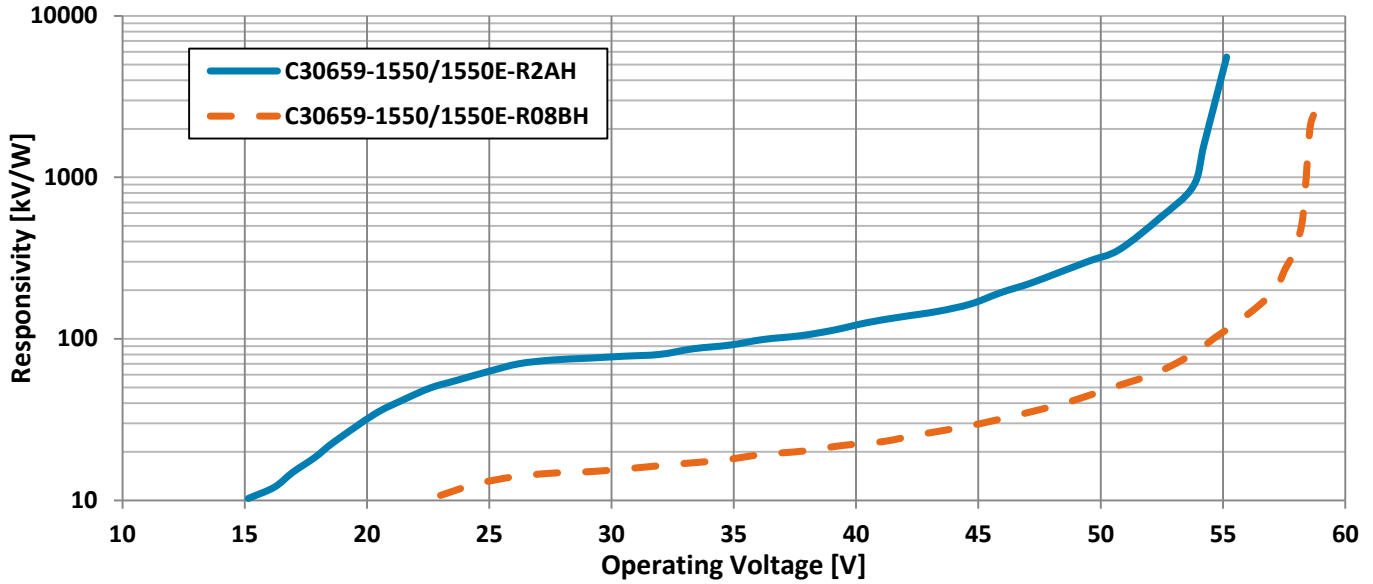
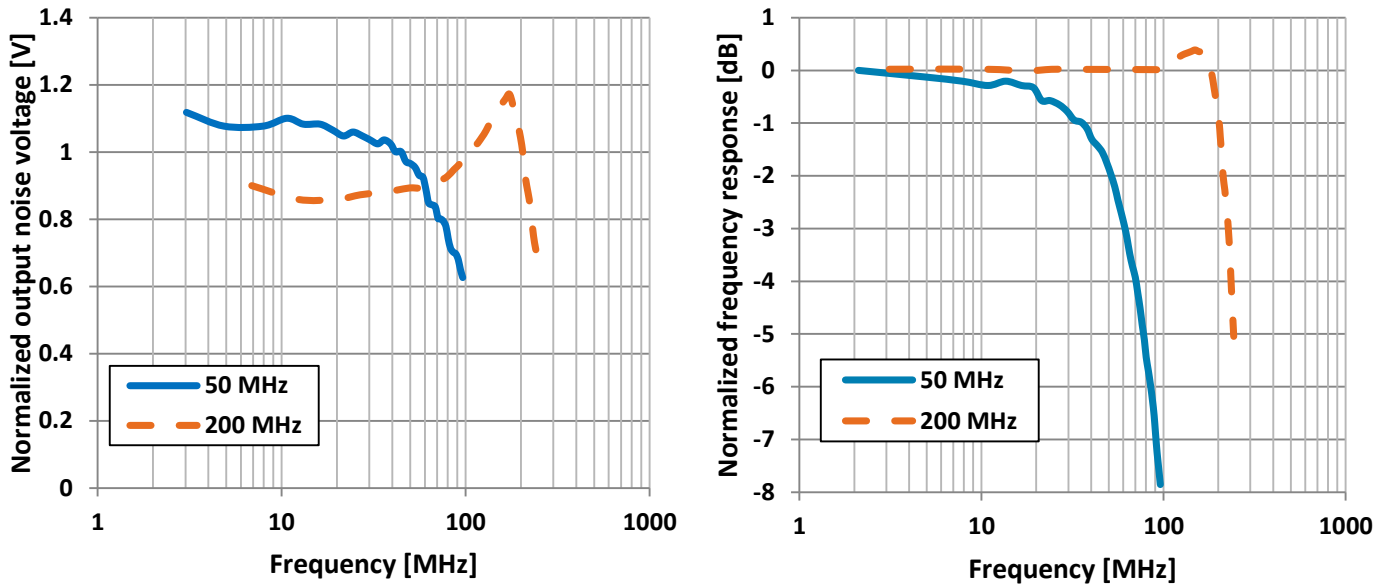

Figure 5. Typical Noise and Frequency response curves



Output voltage noise normalization is calculated using the following formula:

$$V_{n_{normalize}} = \frac{V_n}{V_{n_{average}}}, \text{ where } V_{n_{average}} \left[\frac{V}{\sqrt{Hz}} \right] = \sqrt{\frac{\int_{100kHz}^{f_{-3dB}} V_n^2 \cdot df}{f_{-3dB}}}$$

Figure 6. Typical variation of responsivity as a function of temperature

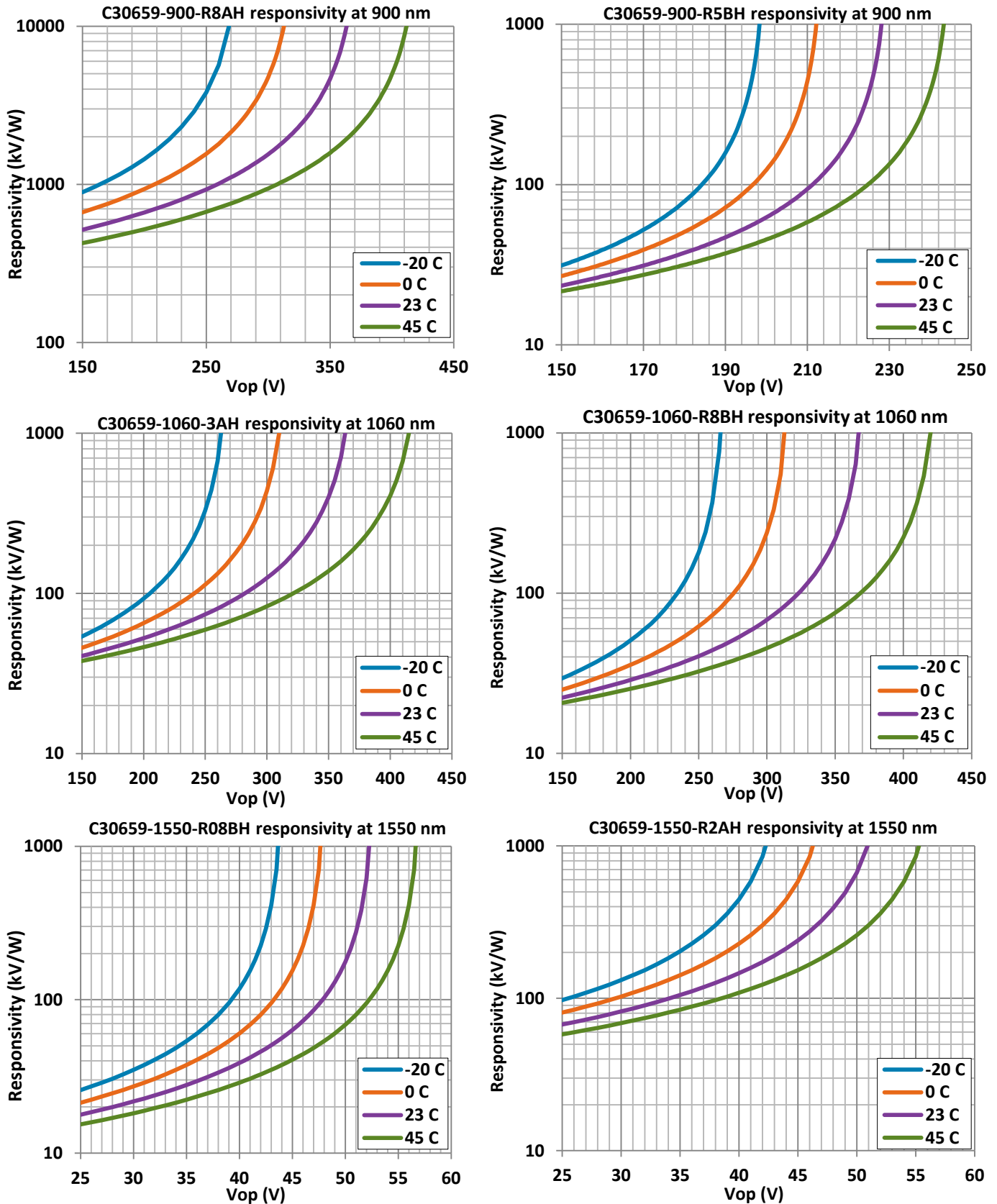

Si and InGaAs APD Preamplifier Modules

Figure 7. Mechanical Characteristics – C30659 Series – reference dimensions shown in inches [mm]

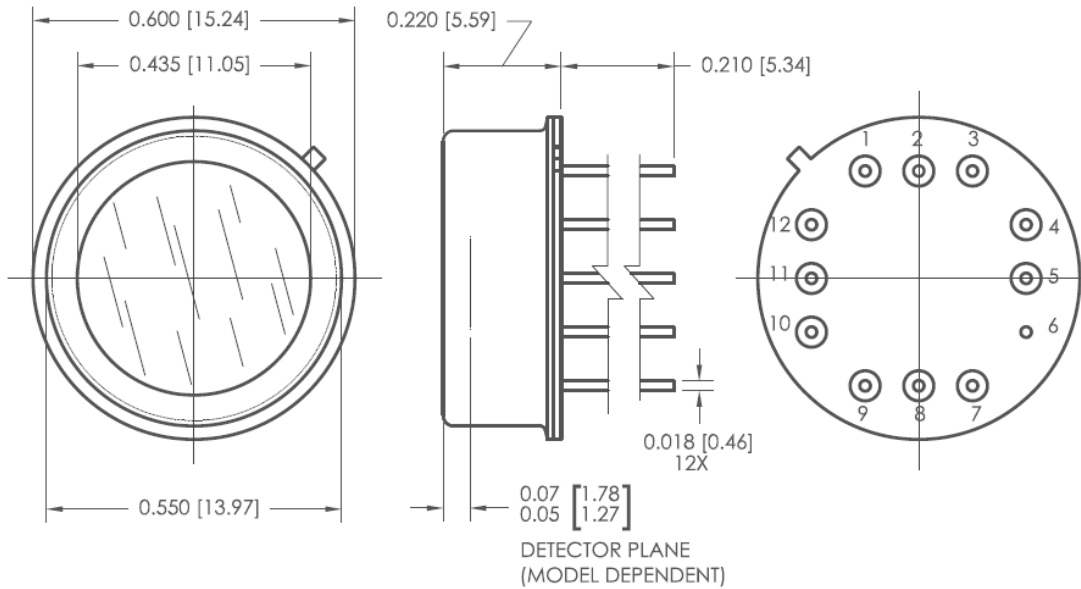

PIN #	DESC	PIN #	DESC
1	OUTPUT	7	NC
2	NC	8	THERM
3	-Vcc AMP BIAS	9	THERM
4	+HV	10	GND, DC RETURNS
5	NC	11	NC
6	CASE GND	12	+Vcc AMP BIAS

DIMENSIONS ARE IN INCHES [MILLIMETERS] AND ARE FOR REFERENCE ONLY

VS-380R1

Figure 8. Approximate field of view – C30659 Series

For incident radiation at angles $\leq \alpha/2$, the photosensitive surface is totally illuminated.

For incident radiation at angles $> \alpha/2$, but $\leq \alpha'/2$, the photosensitive surface is partially illuminated.

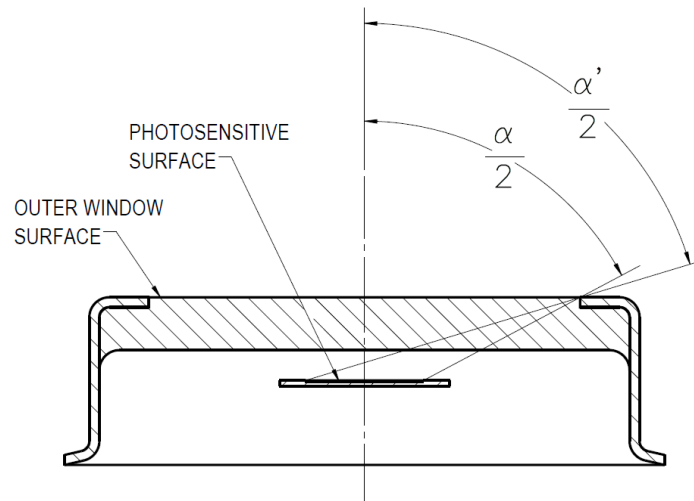

VS-383

C30659 Series – 900/1060/1550/1550E

Si and InGaAs APD Preamplifier Modules

Ordering Guide

Model	APD Material	Nominal Bandwidth	Wavelength Response	APD Used	Active Diameter	Comments
C30659-900-R8AH	Silicon	50 MHz	900 nm (peak)	C30817EH	0.8 mm	
C30659-900-R5BH		200 MHz		C30902EH	0.5 mm	
C30659-1060-3AH		50 MHz	1060 nm (optimized)	C30956EH	3.0 mm	
C30659-1060-R8BH		200 MHz		C30954EH	0.8 mm	
C30659-1550-R2AH	InGaAs	50 MHz	1550 nm (peak)	C30662EH	0.2 mm	
C30659-1500-R08BH		200 MHz		C30645EH	0.08 mm	
C30659-1550E-R2AH		50 MHz		C30662EH	0.2 mm	Enhanced damage threshold
C30659-1550E-R08BH		200 MHz		C30645EH	0.08 mm	

RoHS Compliance

The C30659 Series of APD Preamplifier Modules are designed and built to be fully compliant with the European Union Directive 2011/65/EU – Restriction of the use of certain Hazardous Substances (RoHS) in Electrical and Electronic equipment.



About Excelitas Technologies

Excelitas Technologies is a global technology leader focused on delivering innovative, customized solutions to meet the lighting, detection and other high-performance technology needs of OEM customers.

Excelitas has a long and rich history of serving our OEM customer base with optoelectronic sensors and modules for more than 45 years beginning with PerkinElmer, EG&G, and RCA. The constant throughout has been our innovation and commitment to delivering the highest quality solutions to our customers worldwide.

From aerospace and defense to analytical instrumentation, clinical diagnostics, medical, industrial, and safety and security applications, Excelitas Technologies is committed to enabling our customers' success in their specialty end-markets. Excelitas Technologies has approximately 3,000 employees in North America, Europe and Asia, serving customers across the world.

Excelitas Technologies
22001 Dumberry Road
Vaudreuil-Dorion, Quebec
Canada J7V 8P7
Telephone: (+1) 450.424.3300
Toll-free: (+1) 800.775.6786
Fax: (+1) 450.424.3345
detection.na@excelitas.com

**Excelitas Technologies
GmbH & Co. KG**
Wenzel-Jaksch-Str. 31
D-65199 Wiesbaden
Germany
Telephone: (+49) 611 492 430
Fax: (+49) 611 492 165
detection.europe@excelitas.com

Excelitas Technologies Singapore, Pte. Ltd.
1 Fusionopolis Walk, #11-02
Solaris South Tower
Singapore 138628
Telephone: (+65) 6775 2022 (Main)
Telephone: (+65) 6770 4366 (Cust. Svc.)
Fax: (+65) 6778 1752
detection.asia@excelitas.com

EXCELITAS®
TECHNOLOGIES

For a complete listing of our global offices, visit www.excelitas.com/locations

© 2013 Excelitas Technologies Corp. All rights reserved. The Excelitas logo and design are registered trademarks of Excelitas Technologies Corp. All other trademarks not owned by Excelitas Technologies or its subsidiaries that are depicted herein are the property of their respective owners. Excelitas reserves the right to change this document at any time without notice and disclaims liability for editorial, pictorial or typographical errors.