

### Features

- Collector-Emitter Voltage:  $V_{CEO}=50V$
- Collector Dissipation:  $P_C(\text{max})=625mW$

### Absolute Maximum Ratings (TA=25°C)

Characteristic	Symbol	Rating	Unit
Collector-Base Voltage	$V_{CBO}$	60	V
Collector-Emitter Voltage	$V_{CEO}$	50	V
Emitter-Base Voltage	$V_{EBO}$	5	V
Collector Current	$I_C$	150	mA
Collector Dissipation	$P_C$	625	mW
Junction Temperature	$T_J$	150	°C
Storage Temperature	$T_{STG}$	-55~+150	°C

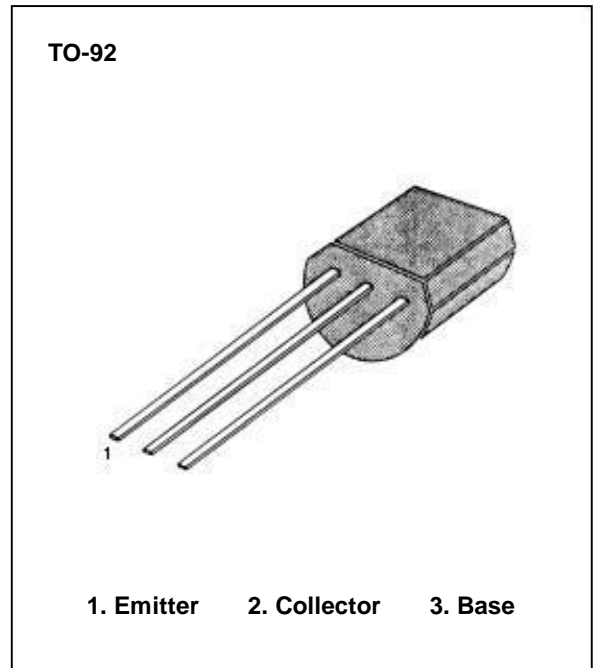

### Electrical Characteristics (TA=25°C)

Characteristic	Symbol	Test Conditions	Min	Typ	Max	Unit
Collector-Base Breakdown Voltage	$BV_{CBO}$	$I_C=100\mu A, I_E=0$	60			V
Collector-Emitter Breakdown Voltage	$BV_{CEO}$	$I_C=1mA, I_B=0$	50			V
Emitter-Base Breakdown Voltage	$BV_{EBO}$	$I_E=100\mu A, I_C=0$	5			V
Collector Cut-off Current	$I_{CBO}$	$V_{CB}=60V, I_E=0$			.01	$\mu A$
Emitter Cut-off Current	$I_{EBO}$	$V_{EB}=5V, I_C=0$			0.1	$\mu A$
DC Current Gain	$h_{FE(1)}$	$V_{CE}=6V, I_C=2mA$	70		700	
	$h_{FE(2)}$	$V_{CE}=6V, I_C=150mA$	25	100		
Collector-Emitter Saturation Voltage	$V_{CE(sat)}$	$I_C=100mA, I_B=10mA$		0.1	0.25	V
Base-Emitter Saturation Voltage	$V_{BE(sat)}$	$I_C=100mA, I_B=10mA$			1	V
Transition Frequency	$f_T$	$V_{CE}=10V, I_C=1mA$ $F=30MHz$	80			MHz

### $h_{FE}$ CLASSIFICATION

Classification	O	Y	GR	BL
$h_{FE}$	70-140	120-240	200-400	350-700