

Typical Applications

Base Stations

Features

Surface Mount Package
 Reflow Process Compatible
 Low Phase Noise
 Build in PLL-Circuit

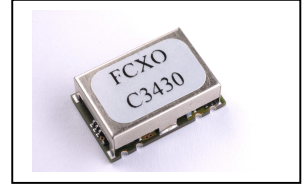

Output Frequency range

10 MHz – 700 MHz

Standard frequencies

52; 61.44; 104, 122,88 MHz

Reference Frequency

Parameter	Min	Typ	Max.	Units	Condition	Ordering Code ⁵
Input frequency Pin 2	1		160	MHz	± 2 ppm	
Standard input frequencies		10 13 26 32,768		MHz MHz MHz MHz		X106 X136 X266 X326
Parameter	Min	Typ	Max.	Units	Condition	
Reference Level	0.5			V _{pp}	@ 2 kΩ	
Reference Input Impedance	2			kΩ		
Harmonics			-30	dBc		

Output Frequency

Parameter	Min	Typ	Max.	Units	Condition	Ordering Code ⁵
output frequency Pin 4	10		700	MHz		
Standard output frequencies		52 61.44		MHz		X526 X616

Supply voltage (Vs)

Parameter	Min	Typ	Max.	Units	Condition	Ordering Code ⁵
Supply voltage [Standard]	3.135	3.3	3.465	VDC		SV033
Current consumption			50	mA	steady state @ +25°C & 3.3VDC	

RF output

Parameter	Min	Typ	Max.	Units	Condition	Ordering Code ⁵
Signal [Standard]		HCMOS				RFH
Load		15		pF	with Vs=3.3V and 15pF load with Vs=3.3V and 15pF load @ (Voh-Vol)/2	
Signal Level (Vol)			0.3	VDC		
Signal Level (Voh)	3.0			VDC		
Rise and Fall time			5	ns		
Duty cycle	40		60	%		

Additional parameters

Parameter	Min	Typ	Max.	Units	Condition	
Phase Noise ³		-80 -110 -135 -150 -155		dBc/Hz dBc/Hz dBc/Hz dBc/Hz dBc/Hz	10 Hz 100 Hz 1 kHz 10 kHz 100 kHz	@ 61.44 MHz

Additional parameters

Parameter	Min	Typ	Max.	Units	Condition
VCXO Control PIN 7	0.5		2.5	V	
Weight			9	g	
Processing & Packing	Handling & processing note				
Operating temperature range	-20		+70	°C	
Operable temperature range	-30		+85	°C	
Storage temperature range	-55		+125	°C	

Enclosures

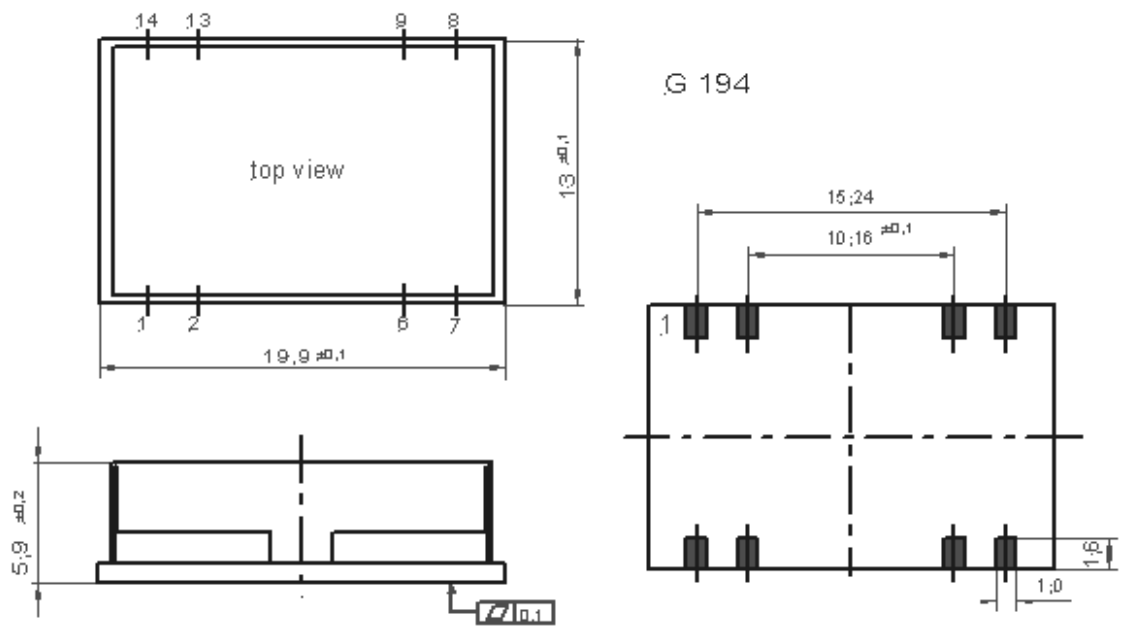
Type G194			
Package Codes:			
Code A1	Height "H" 5.9	Pin Length "L" NA	
			
Dimensions: mm			
Pin Connections	Description		
1	VCXO Control	Test output of the control voltage for the VCXO (0.5V to 2.8V) Only for modul test or observance	
2	Lock Detector Output	Test output signal for PLL lock detected. Low signal ⇒ PLL out of lock High signal ⇒ PLL in lock	
6;6;9	GND	Only for modul test or observance Ground connection. Keep traces physically short and connect immediately to ground plane for best performance	
8	RF-OUT	RF synchronised output.	
13	Ref. Frequency in	High stabel input frequency for synchronisation, This input is AC coupled, so an external blocking capacitor is not necessary.	
14	Vs	Power supply pin. External low frequency bypass capacitor should be connected	
Marking			
C3430A1-xxxx Frequency * VI AYYWW			

Absolute Maximum Ratings

Parameter	Min	Typ	Max.	Units	Condition
Supply voltage (Vs)			6.0	V	
Maximum output load @ CMOS			40	pF	

Typical measurement data

Phase Noise and Jitter

C3530A1 with 32.768MHz in & 52MHz out
FCXO fm=32,768 MHz; fout=52 MHz

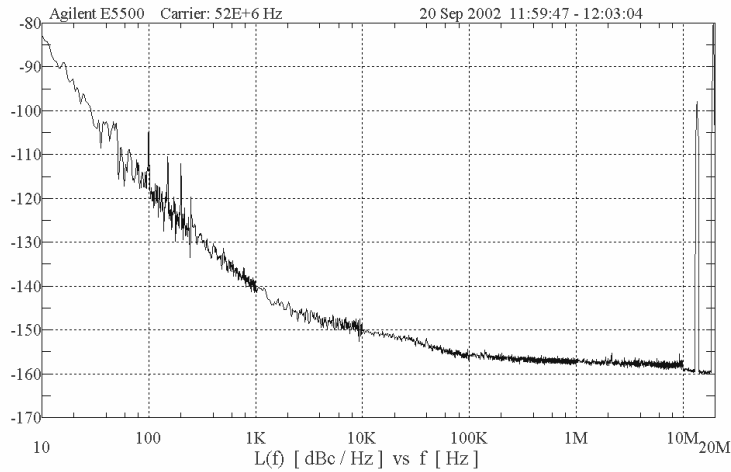

Frequency range [Hz]	S ϕ (f) [dB]	Jitter [ps rms]
100 Hz to 1.5 MHz	-61,86	1.616 ps
50 kHz to 1.5MHz	-62,07	1.578 ps

Block Diagramm

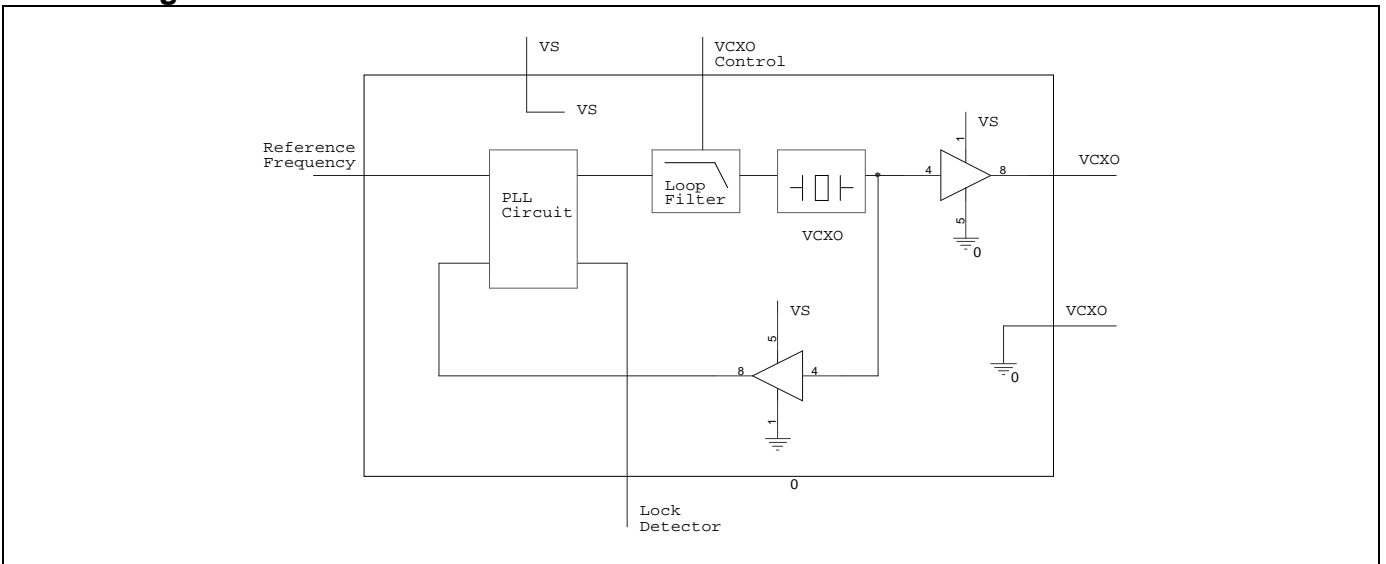

Standard Shipping Method

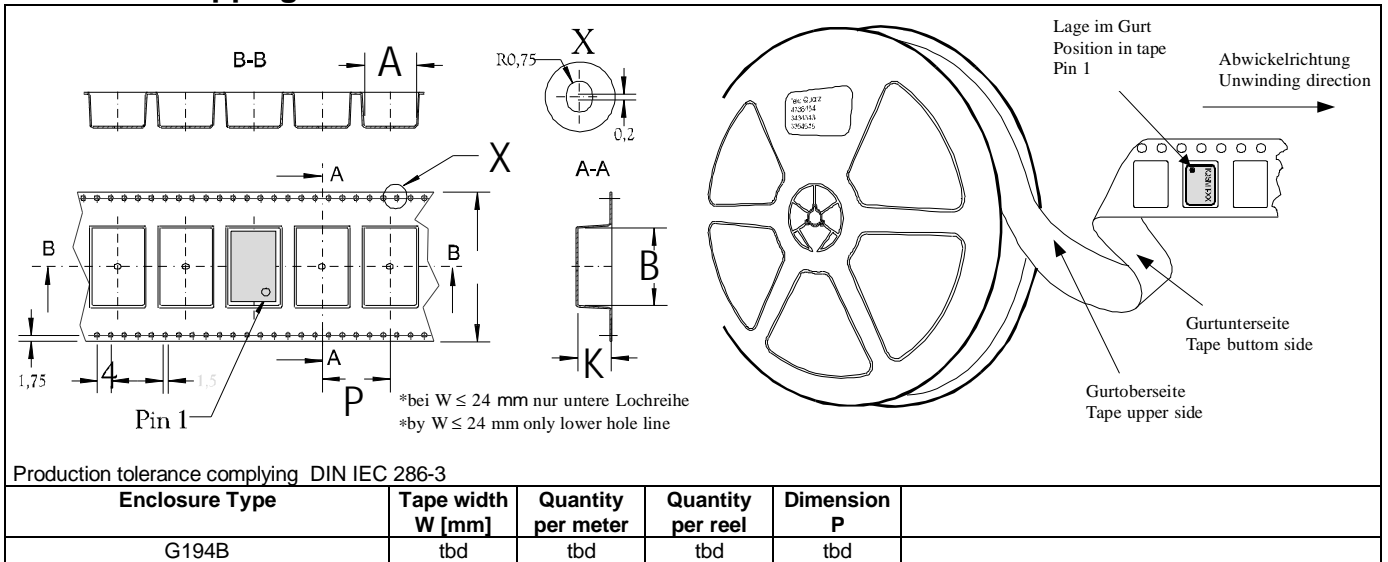

Recommended Reflow Profile

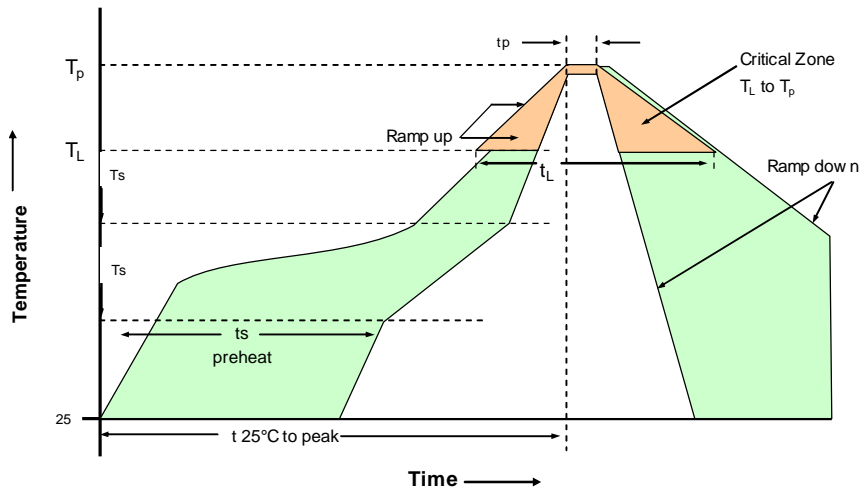

SMD oscillators must be on the top side of the PCB during the reflow process.

Profile Feature	Pb-Free Assembly/Sn-Pb Assembly
Average ramp-up rate (T_L to T_p)	3°C/second max.
Preheat -Temperature Min $T_{s_{min}}$ -Temperature Min $T_{s_{max}}$ -Time (min to max) (t_s)	150°C 200°C 60-180 seconds
$T_{s_{max}}$ to T_L - Ramp-up Rate	3°C/second max.
Time maintained above - Temperature (T_L) - Time (t_L)	217°C 60-150 seconds
Peak Temperature (T_p)	max 260°C
Time within 5°C of actual Peak Temperature (t_p)	20-40 seconds
Ramp-down Rate	6°C/second max.
Time 25°C to Peak Temperature	8 minutes max.

Note: All temperatures refer to topside of the package, measured on the package body surface.

How to Order this Product:

Step 1	Use this worksheet to forward the following information to your factory representative:					
Model	Ref. Freq	Freq out	Supply Voltage Code	RF Output Code	Package Code	
C3430						

Example: C3430 X326 X526 SV033 RFC A1

Step 2	The factory representative will then respond with a Vectron Model Number in the following Configuration:			
Model	Package Code	Dash	Dash Number	
C3430	[Customer Specified Package Code]	-	[Factory Generated 4 digit number]	

Typical P/N = C3430A1-0001

Notes:

- 1 Contact factory for improved stabilities or additional product options. Not all options and codes are available at all frequencies.
- 2 Unless otherwise stated all values are valid after warm-up time and refer to typical conditions for supply voltage, frequency control voltage, load, temperature (25°C)
- 3 Phase noise degrades with increasing output frequency.
- 4 Subject to technical modification.
- 5 Contact factory for availability.