

C431PM

- Power Thyristor

1600 V_{DRM};

HIGH POWER THYRISTOR FOR PHASE CONTROL APPLICATIONS

Features:

- . All Diffused Structure
- . Center Amplifying Gate Configuration
- . Blocking capability up to 1600 volts
- . Guaranteed Maximum Turn-Off Time
- . High dV/dt Capability
- . Pressure Assembled Device

CASE 2T

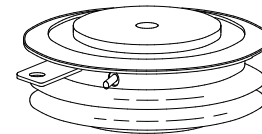

ELECTRICAL CHARACTERISTICS AND RATINGS

Blocking - Off State

Device Type	V _{RRM} (1)	V _{DRM} (1)	V _{RSM} (1)
C431PM	1600	1600	1700

- V_{RRM} = Repetitive peak reverse voltage
- V_{DRM} = Repetitive peak off state voltage
- V_{RSM} = Non repetitive peak reverse voltage (2)

Notes:

- All ratings are specified for T_j=25 °C unless otherwise stated.
- (1) All voltage ratings are specified for an applied 50Hz/60Hz sinusoidal waveform over the temperature range -40 to +125 °C.
 - (2) 10 msec. max. pulse width
 - (3) Maximum value for T_j = 125 °C.
 - (4) Minimum value for linear and exponential waveshape to 80% rated V_{DRM}. Gate open. T_j = 125 °C.
 - (5) Non-repetitive value.
 - (6) The value of di/dt is established in accordance with EIA/NIMA Standard RS-397, Section 5-2-2-6. The value defined would be in addition to that obtained from a snubber circuit, comprising a 0.2 μF capacitor and 20 ohms resistance in parallel with the thristor under test.

Repetitive peak reverse leakage and off state leakage	I _{RRM} / I _{DRM}	30 mA (3)
Critical rate of voltage rise (4)	dV/dt	200 V/μsec

Conducting - on state

Parameter	Symbol	Min.	Max.	Typ.	Units	Conditions
Average value of on-state current	I _{T(AV)}		600		A	Sinewave, 180° conduction, T _c = 65°C
RMS value of on-state current	I _{TRMS}		940		A	Nominal value
Peak one cPSTCle surge (non repetitive) current	I _{TSM}		7500		A	8.3 msec (60Hz), sinusoidal wave-shape, 180° conduction, T _j = 125 °C
			7200		A	10.0 msec (50Hz), sinusoidal wave-shape, 180° conduction, T _j = 125 °C
I square t	I ² t		235000		A ² s	8.3 msec and 10.0 msec
Latching current	I _L		800		mA	V _D = 24 V; R _L = 12 ohms
Holding current	I _H		400		mA	V _D = 24 V; I = 2.5 A
Peak on-state voltage	V _{TM}		2.30		V	I _{TM} = 2000 A; Duty cPSTCle ≤ 0.01%
Critical rate of rise of on-state current (5, 6)	di/dt		200		A/μs	Switching from V _{DRM} ≤ 1000 V, non-repetitive
Critical rate of rise of on-state current (6)	di/dt		100		A/μs	Switching from V _{DRM} ≤ 1000 V

ELECTRICAL CHARACTERISTICS AND RATINGS

C431PM - Power Thyristor

Gating

Parameter	Symbol	Min.	Max.	Typ.	Units	Conditions
Peak gate power dissipation	P_{GM}		200		W	$t_p = 40 \mu s$
Average gate power dissipation	$P_{G(AV)}$		5		W	
Peak gate current	I_{GM}		10		A	
Gate current required to trigger all units	I_{GT}		300 150 125		mA mA mA	$V_D = 6 V; R_L = 3 \text{ ohms}; T_j = -40 \text{ }^\circ\text{C}$ $V_D = 6 V; R_L = 3 \text{ ohms}; T_j = +25 \text{ }^\circ\text{C}$ $V_D = 6 V; R_L = 3 \text{ ohms}; T_j = +125 \text{ }^\circ\text{C}$
Gate voltage required to trigger all units	V_{GT}	0.15	5 3		V V V	$V_D = 6 V; R_L = 3 \text{ ohms}; T_j = -40 \text{ }^\circ\text{C}$ $V_D = 6 V; R_L = 3 \text{ ohms}; T_j = 0-125 \text{ }^\circ\text{C}$ $V_D = \text{Rated } V_{DRM}; R_L = 1000 \text{ ohms}; T_j = +125 \text{ }^\circ\text{C}$
Peak negative voltage	V_{GRM}		5		V	

Dynamic

Parameter	Symbol	Min.	Max.	Typ.	Units	Conditions
Delay time	t_d		1.5	0.7	μs	$I_{TM} = 50 \text{ A}; V_D = \text{Rated } V_{DRM}$ Gate pulse: $V_G = 20 \text{ V}; R_G = 20 \text{ ohms}; t_r = 0.1 \mu s; t_p = 20 \mu s$
Turn-off time (with $V_R = -50 \text{ V}$)	t_q		200	125	μs	$I_{TM} = 500 \text{ A}; di/dt = 25 \text{ A}/\mu s;$ $V_R \geq -50 \text{ V};$ Re-applied $dV/dt = 20 \text{ V}/\mu s$ linear to 80% $V_{DRM}; V_G = 0;$ $T_j = 125 \text{ }^\circ\text{C};$ Duty cPSTCle $\geq 0.01\%$
Reverse recovery charge	Q_{rr}		*		μC	$I_{TM} = 500 \text{ A}; di/dt = 25 \text{ A}/\mu s;$ $V_R \geq -50 \text{ V}$

* For guaranteed max. value, contact factory.

THERMAL AND MECHANICAL CHARACTERISTICS AND RATINGS

Parameter	Symbol	Min.	Max.	Typ.	Units	Conditions
Operating temperature	T_j	-40	+125		$^\circ\text{C}$	
Storage temperature	T_{stg}	-40	+150		$^\circ\text{C}$	
Thermal resistance - junction to case	$R_{\theta(j-c)}$	0.045 (1)	0.055 (2)		$^\circ\text{C}/\text{W}$	Double sided cooled * (1) @ 2000 lb.; (2) @ 800 lb.
Thermal resistance - junction to case	$R_{\theta(j-c)}$	0.090 (1)	0.110 (2)		$^\circ\text{C}/\text{W}$	Single sided cooled * (1) @ 2000 lb.; (2) @ 800 lb.
Thermal resistance - case to sink	$R_{\theta(c-s)}$.030 .060		$^\circ\text{C}/\text{W}$	Double sided cooled * Single sided cooled *
Mounting force	P	800 3.6	2500 11.1		lb. kN	
Weight	W			2.5 70	oz. g	

* Mounting surfaces smooth, flat and greased

Note : for case outline and dimensions, see case outline drawing in page 4 of this Technical Data

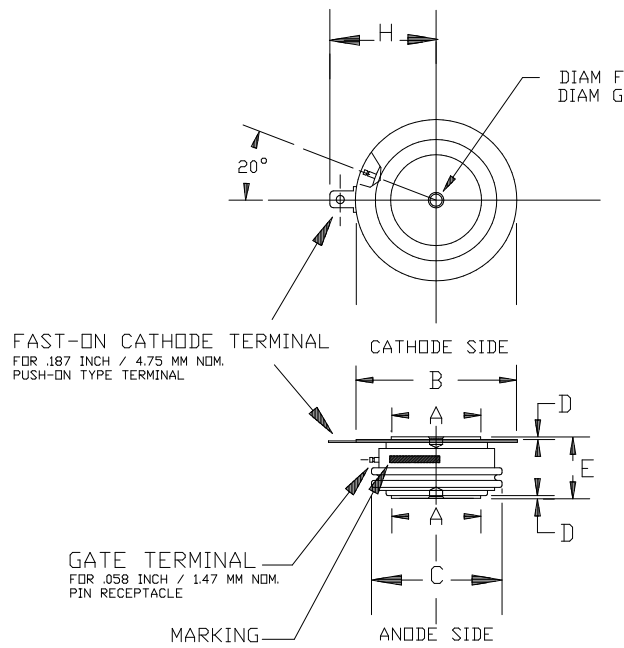

STRIKE DISTANCE = .23 INCH / 5.8 MM MIN.
 CREEPAGE DISTANCE = .40 INCH / 10.2 MM MIN.

OUTLINE DIMENSIONS - CASE 2T				
DIMENSIONS	Min. mm	Max. mm	Min. In.	Max. In.
DIAM A	24.89	25.40	0.98	1.00
DIAM B	40.64	42.16	1.60	1.65
DIAM C	--	40.39	--	1.59
D	0.76	--	0.03	--
E	13.72	15.24	0.54	0.60
F	3.30	3.81	0.13	0.15
G	1.78	2.03	0.07	0.08
H	27.69	28.70	1.09	1.13