

TOSHIBA Transistor Silicon NPN Epitaxial Planar Type

2SC4844

VHF~UHF Band Low Noise Amplifier Applications

Unit: mm

- Low noise figure, high gain.
- $NF = 1.8\text{dB}$, $|S_{21e}|^2 = 9.5\text{dB}$ ($f = 2\text{GHz}$)

Maximum Ratings ($T_a = 25^\circ\text{C}$)

Characteristics	Symbol	Rating	Unit
Collector-base voltage	V_{CBO}	20	V
Collector-emitter voltage	V_{CEO}	10	V
Emitter-base voltage	V_{EBO}	1.5	V
Base current	I_B	7	mA
Collector current	I_C	15	mA
Collector power dissipation	P_C	100	mW
Junction temperature	T_j	125	$^\circ\text{C}$
Storage temperature range	T_{stg}	-55~125	$^\circ\text{C}$

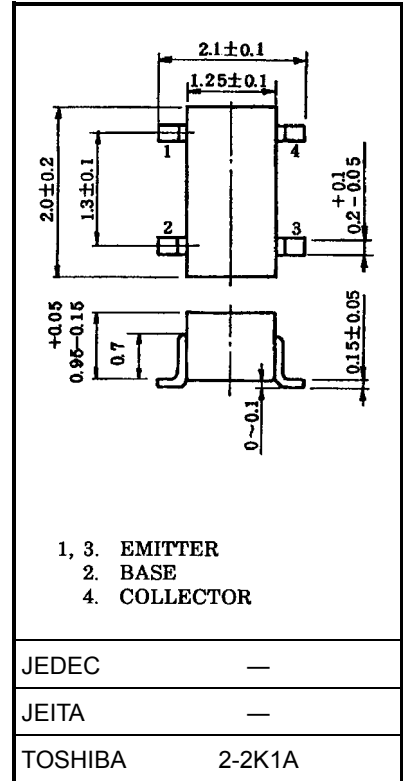

Microwave Characteristics ($T_a = 25^\circ\text{C}$)

Weight: 0.006 g (typ.)

Characteristics	Symbol	Test Condition	Min	Typ.	Max	Unit
Transition frequency	f_T	$V_{CE} = 6\text{V}$, $I_C = 7\text{mA}$	7	10	—	GHz
Insertion gain	$ S_{21e} ^2 (1)$	$V_{CE} = 6\text{V}$, $I_C = 7\text{mA}$, $f = 1\text{GHz}$	—	15	—	dB
	$ S_{21e} ^2 (2)$	$V_{CE} = 6\text{V}$, $I_C = 7\text{mA}$, $f = 2\text{GHz}$	6.5	9.5	—	
Noise figure	NF (1)	$V_{CE} = 6\text{V}$, $I_C = 3\text{mA}$, $f = 1\text{GHz}$	—	1.4	—	dB
	NF (2)	$V_{CE} = 6\text{V}$, $I_C = 3\text{mA}$, $f = 2\text{GHz}$	—	1.8	3.0	

Electrical Characteristics ($T_a = 25^\circ\text{C}$)

Characteristics	Symbol	Test Condition	Min	Typ.	Max	Unit
Collector cut-off current	I_{CBO}	$V_{CB} = 10\text{V}$, $I_E = 0$	—	—	1	μA
Emitter cut-off current	I_{EBO}	$V_{EB} = 1\text{V}$, $I_C = 0$	—	—	1	μA
DC current gain	h_{FE}	$V_{CE} = 6\text{V}$, $I_C = 7\text{mA}$	50	—	250	
Output capacitance	C_{ob}	$V_{CB} = 10\text{V}$, $I_E = 0$, $f = 1\text{MHz}$ (Note)	—	0.55	—	pF
Reverse transfer capacitance	C_{re}		—	0.35	0.8	pF

Note: C_{re} is measured by 3 terminal method with capacitance bridge.

Marking

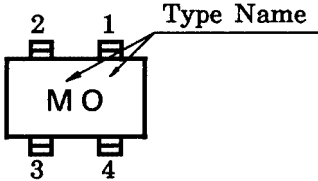

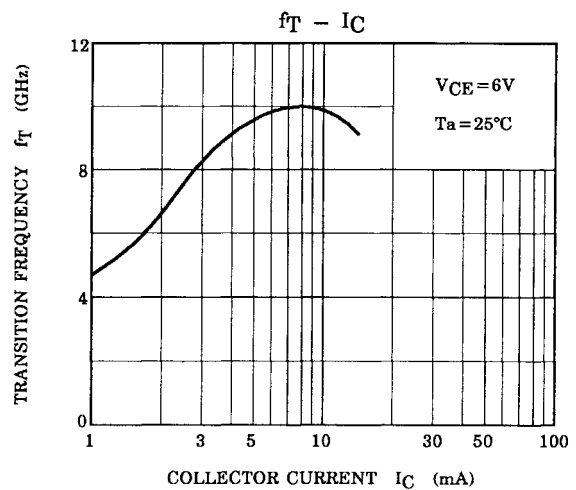
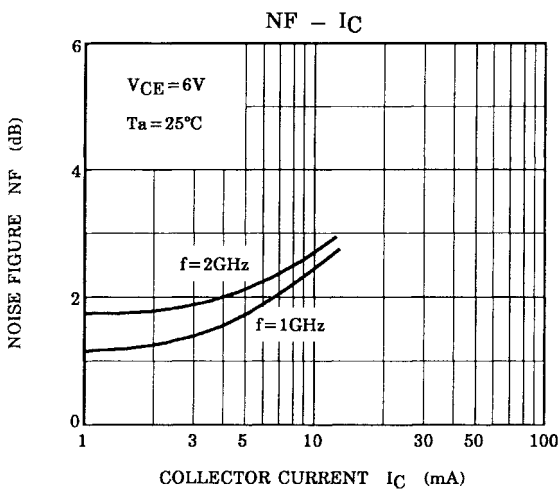
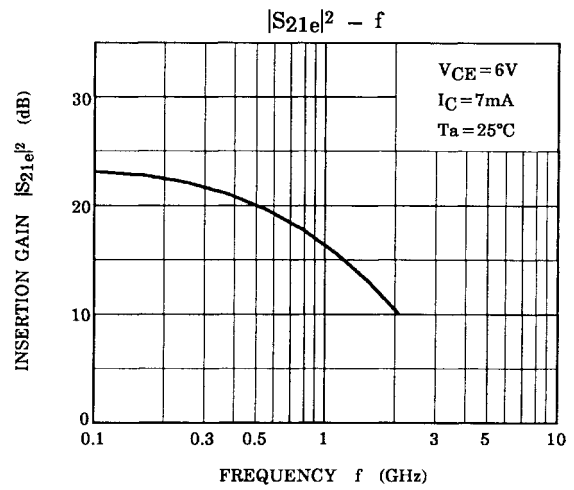
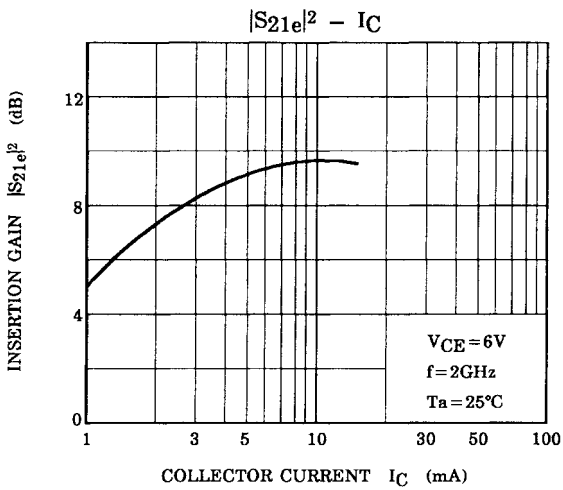
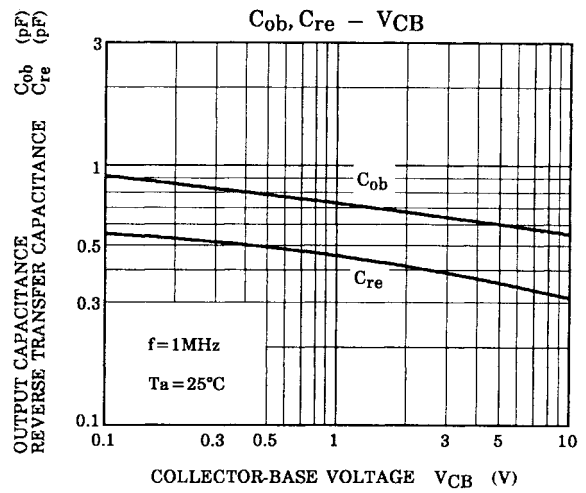
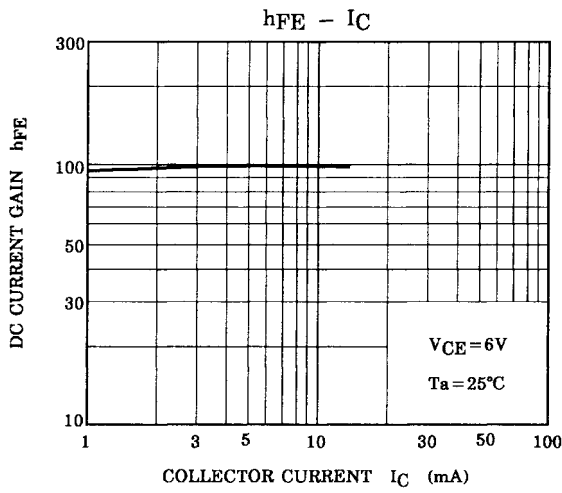

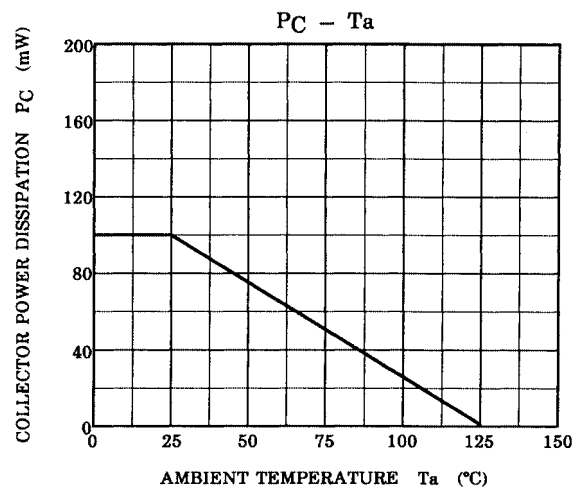
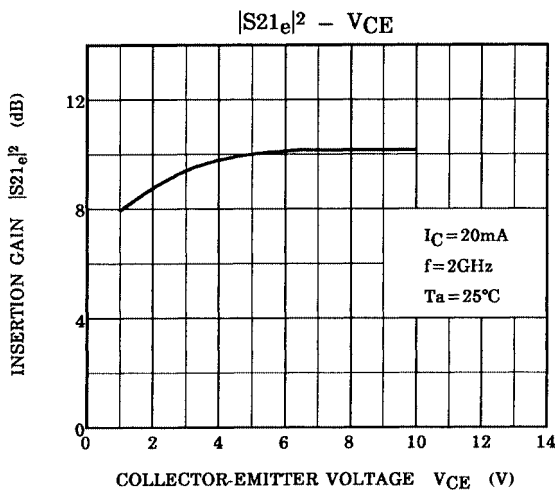

S-Parameter $Z_O = 50 \Omega$, $T_a = 25^\circ\text{C}$

$V_{CE} = 6 \text{ V}$, $I_C = 3 \text{ mA}$

Frequency MHz	S11		S21		S12		S22	
	MAG	ANG	MAG	ANG	MAG	ANG	MAG	ANG
200	0.847	-22.2	7.290	159.9	0.037	75.5	0.954	-16.2
400	0.767	-43.8	6.718	143.8	0.066	64.5	0.857	-29.3
600	0.666	-63.7	6.064	129.8	0.087	56.5	0.765	-39.3
800	0.573	-80.8	5.332	119.0	0.102	51.3	0.680	-47.0
1000	0.492	-96.6	4.642	109.6	0.113	47.5	0.612	-53.3
1200	0.435	-111.0	4.133	102.7	0.121	45.1	0.560	-58.2
1400	0.393	-122.1	3.671	96.6	0.126	44.0	0.518	-62.6
1600	0.366	-132.7	3.314	92.1	0.131	43.5	0.486	-66.5
1800	0.351	-141.5	3.051	88.0	0.136	43.4	0.466	-70.2
2000	0.340	-149.6	2.820	83.7	0.141	43.8	0.450	-73.2

$V_{CE} = 6 \text{ V}$, $I_C = 7 \text{ mA}$

Frequency MHz	S11		S21		S12		S22	
	MAG	ANG	MAG	ANG	MAG	ANG	MAG	ANG
200	0.708	-36.8	13.239	151.4	0.032	70.2	0.890	-23.8
400	0.582	-69.7	11.041	131.1	0.053	59.2	0.718	-39.1
600	0.491	-96.0	8.920	116.6	0.066	54.3	0.589	-48.1
800	0.425	-116.4	7.290	107.1	0.074	52.7	0.502	-53.8
1000	0.386	-133.3	6.049	99.4	0.082	52.7	0.442	-58.0
1200	0.368	-147.0	5.176	94.3	0.090	53.5	0.405	-61.3
1400	0.353	-157.1	4.527	89.3	0.097	54.5	0.378	-64.7
1600	0.347	-166.1	4.007	85.7	0.105	55.7	0.359	-67.9
1800	0.345	-172.9	3.634	82.2	0.113	56.7	0.347	-70.7
2000	0.344	-179.0	3.333	78.8	0.120	57.9	0.340	-74.1

S11e
 VCE=6V
 IC=3mA
 Ta=25°C
 (UNIT : Ω)

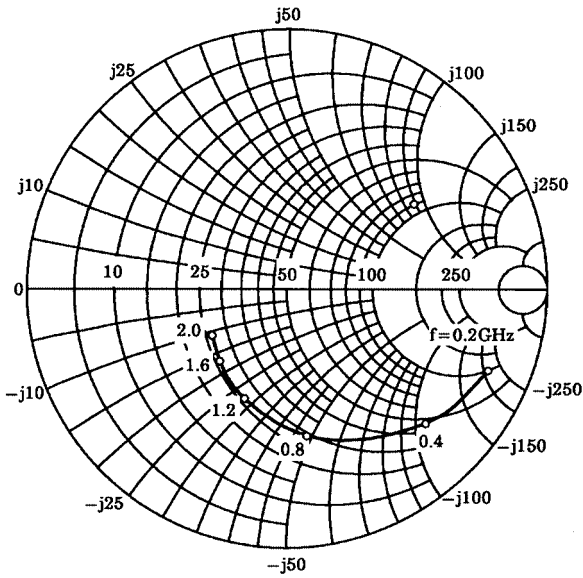

S21e
 VCE=6V
 IC=3mA
 Ta=25°C

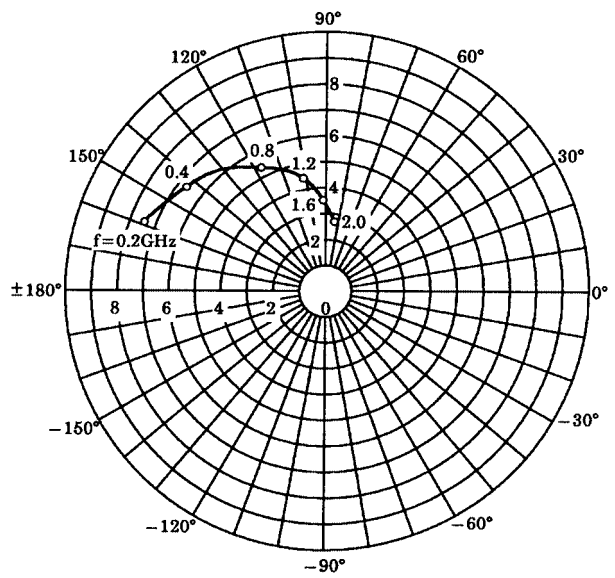

S12e
 VCE=6V
 IC=3mA
 Ta=25°C

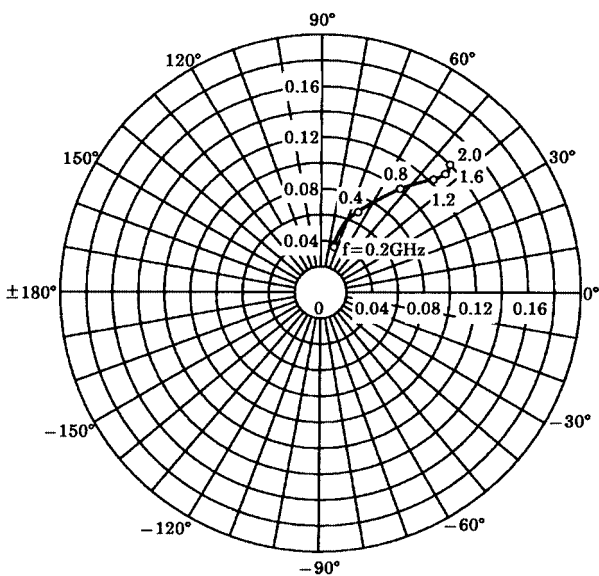

S22e
 VCE=6V
 IC=3mA
 Ta=25°C
 (UNIT : Ω)

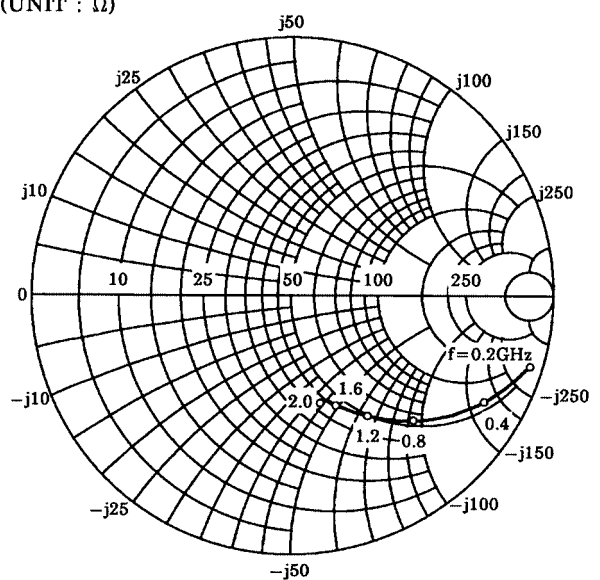

S_{11e}
 V_{CE}=6V
 I_C=7mA
 T_a=25°C
 (単位 : Ω)

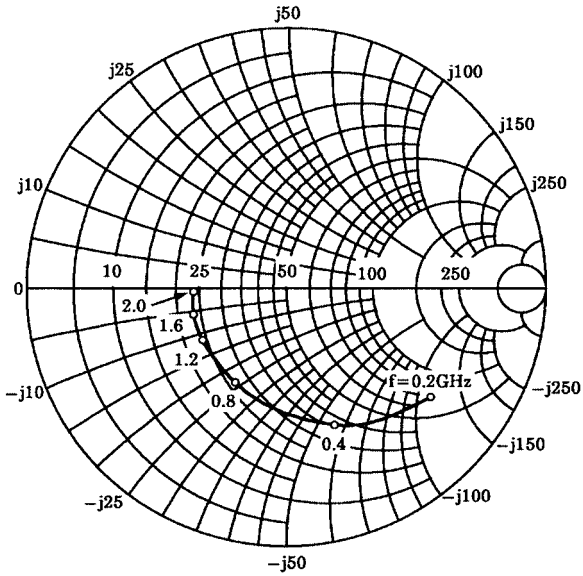

S_{21e}
 V_{CE}=6V
 I_C=7mA
 T_a=25°C

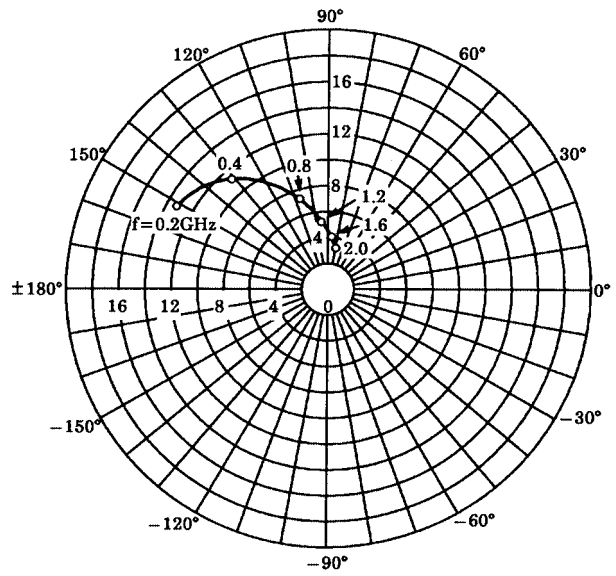

S_{12e}
 V_{CE}=6V
 I_C=7mA
 T_a=25°C

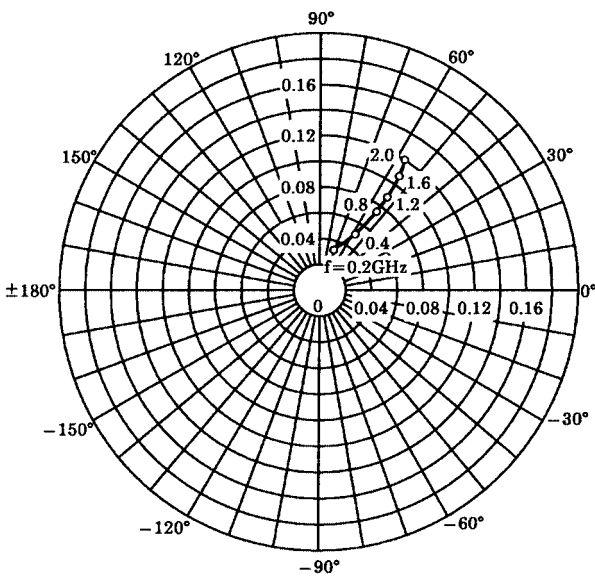

S_{22e}
 V_{CE}=6V
 I_C=7mA
 T_a=25°C
 (単位 : Ω)

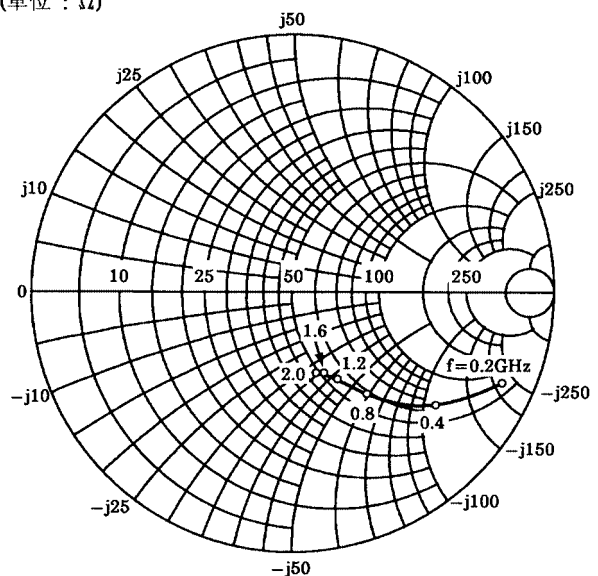

RESTRICTIONS ON PRODUCT USE

000707EAA

- TOSHIBA is continually working to improve the quality and reliability of its products. Nevertheless, semiconductor devices in general can malfunction or fail due to their inherent electrical sensitivity and vulnerability to physical stress. It is the responsibility of the buyer, when utilizing TOSHIBA products, to comply with the standards of safety in making a safe design for the entire system, and to avoid situations in which a malfunction or failure of such TOSHIBA products could cause loss of human life, bodily injury or damage to property.
In developing your designs, please ensure that TOSHIBA products are used within specified operating ranges as set forth in the most recent TOSHIBA products specifications. Also, please keep in mind the precautions and conditions set forth in the "Handling Guide for Semiconductor Devices," or "TOSHIBA Semiconductor Reliability Handbook" etc..
- The TOSHIBA products listed in this document are intended for usage in general electronics applications (computer, personal equipment, office equipment, measuring equipment, industrial robotics, domestic appliances, etc.). These TOSHIBA products are neither intended nor warranted for usage in equipment that requires extraordinarily high quality and/or reliability or a malfunction or failure of which may cause loss of human life or bodily injury ("Unintended Usage"). Unintended Usage include atomic energy control instruments, airplane or spaceship instruments, transportation instruments, traffic signal instruments, combustion control instruments, medical instruments, all types of safety devices, etc.. Unintended Usage of TOSHIBA products listed in this document shall be made at the customer's own risk.
- The information contained herein is presented only as a guide for the applications of our products. No responsibility is assumed by TOSHIBA CORPORATION for any infringements of intellectual property or other rights of the third parties which may result from its use. No license is granted by implication or otherwise under any intellectual property or other rights of TOSHIBA CORPORATION or others.
- The information contained herein is subject to change without notice.