

2SC495 2SC496

SILICON NPN EPITAXIAL TYPE (PCT PROCESS)

MEDIUM POWER AMPLIFIER APPLICATIONS.

FEATURES:

- Low Collector Saturation Voltage
: $V_{CE(sat)}=0.25V$ (Typ.)
- 0.5~2 Watts Output Application.
- Complementary to 2SA505 and 2SA496.

MAXIMUM RATINGS (Ta=25°C)

CHARACTERISTIC	SYMBOL	RATING	UNIT
Collector-Base Voltage	2SC495	70	V
	2SC496	40	
Collector-Emitter Voltage	2SC495	50	V
	2SC496	30	
Emitter-Base Voltage	V_{EBO}	5	V
Collector Current	I_C	1	A
Emitter Current	I_E	-1	A
Collector Power Dissipation	P_C	1	W
Junction Temperature	T_j	150	°C
Storage Temperature Range	T_{stg}	-55 ~ 150	°C

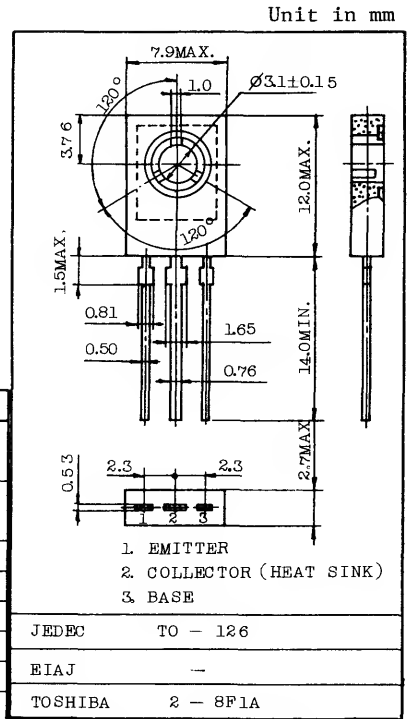

Mounting Kit No. AC46C
Weight : 0.72g

ELECTRICAL CHARACTERISTICS (Ta=25°C)

CHARACTERISTIC	SYMBOL	TEST CONDITION	MIN.	TYP.	MAX.	UNIT	
Collector Cut-off Current	I_{CBO}	$V_{CB}=30V, I_E=0$	-	-	1.0	μA	
Emitter Cut-off Current	I_{EBO}	$V_{EB}=5V, I_C=0$	-	-	1.0	μA	
Collector-Emitter Breakdown Voltage	2SC495 2SC496	$V_{(BR)CEO}$	$I_C=10mA, I_B=0$	50	-	-	V
				30	-	-	
Emitter-Base Breakdown Voltage	$V_{(BR)EBO}$	$I_E=1mA, I_C=0$	5	-	-	V	
DC Current Gain	$h_{FE(1)}$ (Note)	$V_{CE}=2V, I_C=50mA$	40	-	240		
			$h_{FE(2)}$	$V_{CE}=2V, I_C=800mA$	13		-
Collector-Emitter Saturation Voltage	$V_{CE(sat)}$	$I_C=500mA, I_B=50mA$	-	0.25	0.8	V	
Base-Emitter Voltage	V_{BE}	$V_{CE}=2V, I_C=500mA$	-	0.9	1.1	V	
Transition Frequency	f_T	$V_{CE}=10V, I_C=10mA$	50	100	-	MHz	
Collector Output Capacitance	C_{ob}	$V_{CB}=10V, I_E=0, f=1MHz$	-	10	-	pF	

Note : $h_{FE(1)}$ Classification R : 40~80, O : 70~140, Y : 120~240

