

isc Silicon NPN Power Transistor

2SC5248

**DESCRIPTION**

- Collector-Emitter Breakdown Voltage-  
:  $V_{(BR)CEO} = 160V(\text{Min})$
- Good Linearity of  $h_{FE}$
- Wide Area of Safe Operation
- Complement to Type 2SA1964

**APPLICATIONS**

- Power amplifier applications.
- Driver stage amplifier applications.

**ABSOLUTE MAXIMUM RATINGS( $T_a=25^\circ\text{C}$ )**

SYMBOL	PARAMETER	VALUE	UNIT
$V_{CBO}$	Collector-Base Voltage	160	V
$V_{CEO}$	Collector-Emitter Voltage	160	V
$V_{EBO}$	Emitter-Base Voltage	5	V
$I_C$	Collector Current-Continuous	1.5	A
$P_C$	Collector Power Dissipation @ $T_a=25^\circ\text{C}$	2	W
	Collector Power Dissipation @ $T_C=25^\circ\text{C}$	20	
$T_J$	Junction Temperature	150	$^\circ\text{C}$
$T_{stg}$	Storage Temperature	-55~150	$^\circ\text{C}$

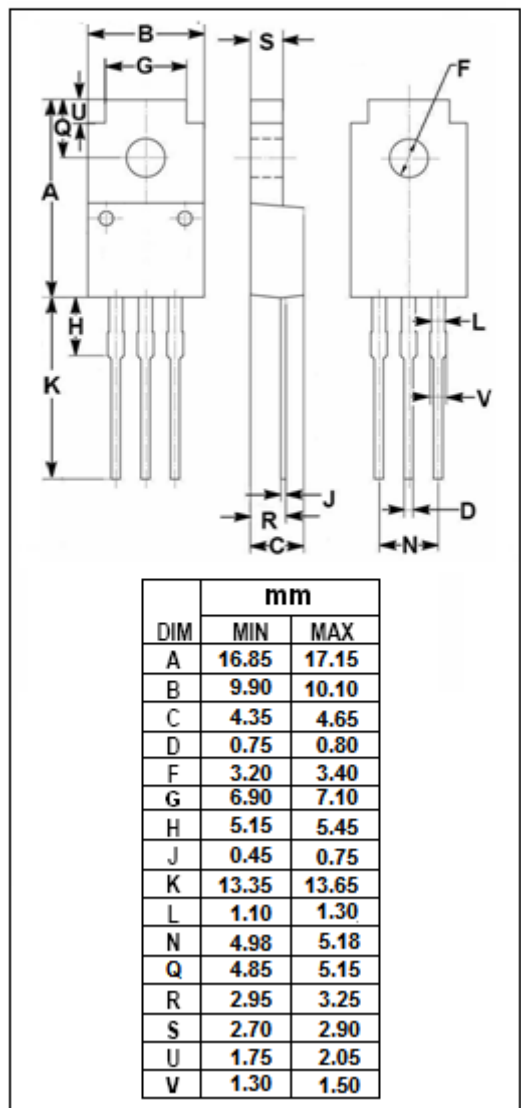
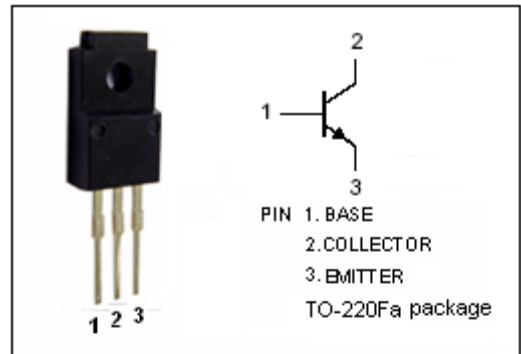

isc Website:

**isc Silicon NPN Power Transistor****2SC5248****ELECTRICAL CHARACTERISTICS****T<sub>j</sub>=25°C unless otherwise specified**

SYMBOL	PARAMETER	CONDITIONS	MIN	TYP.	MAX	UNIT
V <sub>(BR)CEO</sub>	Collector-Emitter Breakdown Voltage	I <sub>C</sub> = 1mA; I <sub>B</sub> = 0	160			V
V <sub>(BR)CBO</sub>	Collector-Base Breakdown Voltage	I <sub>C</sub> = 50 μ A; I <sub>E</sub> = 0	160			V
V <sub>(BR)EBO</sub>	Emitter-Base Breakdown Voltage	I <sub>E</sub> = 50 μ A; I <sub>C</sub> = 0	5			V
V <sub>CE(sat)</sub>	Collector-Emitter Saturation Voltage	I <sub>C</sub> = 1A; I <sub>B</sub> = 0.1A			1.0	V
I <sub>CBO</sub>	Collector Cutoff Current	V <sub>CB</sub> = 160V; I <sub>E</sub> = 0			1.0	μ A
I <sub>EBO</sub>	Emitter Cutoff Current	V <sub>EB</sub> = 4V; I <sub>C</sub> = 0			1.0	μ A
h <sub>FE</sub>	DC Current Gain	I <sub>C</sub> = 0.1A; V <sub>CE</sub> = 5V	60		200	
f <sub>T</sub>	Current-Gain—Bandwidth Product	I <sub>C</sub> = 0.2A; V <sub>CE</sub> = 10V		150		MHz
C <sub>OB</sub>	Output Capacitance	I <sub>E</sub> = 0; V <sub>CB</sub> = 10V; f= 1MHz		20		pF

◆ **h<sub>FE</sub> Classifications**

D	E
60-120	100-200