



Product Specification

C704S0

IEEE 802.11BGN 1T1R & BT4.0

Combo SDIO LGA Module

Version: 0.4

Sep. 24, 2012

Release History

DATE	REV	Description of Change
2012/08/01	0.1	Preliminary specification release
2012/09/13	0.2	Update RF specification
2012/09/14	0.3	Update Pin definitions
2012/09/24	0.4	Update power consumption, RF specifications



C704S0

IEEE 802.11 BGN 1T1R + BT 4.0

Combo SDIO LGA Module

1 Product Features

■ WLAN

- Complies with IEEE802.11 b/g/n 1T1R standard for 2.4GHz band, supports 20MHz and 40MHz bandwidth transmission, Short Guard Interval (400ns)
- Supports 802.11e QoS Enhancement (WMM) and 802.11i (WPA, WPA2)
- Frame aggregation for increased MAC efficiency (A-MSDU, A-MPDU)
- Low latency immediate High-Throughput Block Acknowledgement (HT-BA)
- PHY-level spoofing to enhance legacy compatibility
- Power saving mechanism
- Channel management and co-existence
- Transmit Opportunity (TXOP) Short Inter-Frame Space (SIFS) bursting for higher multimedia bandwidth

■ Bluetooth

- Qualified Bluetooth v2.1, v3.0 and v4.0 LE Systems, supports Bluetooth Low Energy
 - HS-UART interface for BT data transmission compliant with H4 and H5 specification
 - PCM interface for audio data transmission via BT controller
 - Integrated MCU to execute Bluetooth protocol stack
 - Support all packet types in basic rate and enhanced data rate
 - Support SCO / eSCO link (allow one link for PCM interface and three links for HS-UART)
 - Support 4 piconets in a scatternet
 - Support Secure Simple Pairing
 - Support Low Power Mode (Sniff / Sniff Sub-rating / Hold / Park)
 - Bluetooth 4.0 Dual Mode support: Simultaneous LE and BR/EDR
 - Support multiple states of Low Energy to increase the flexibility of application
 - Support AFH to dynamically detect channel quality to improve transmission quality
- Host interface: SDIO 1.1/ 2.0/ 3.0 for WiFi and HS-UART with configurable baud rate for Bluetooth.

- 44-pin QFN like module form factor.

2 Block Diagram

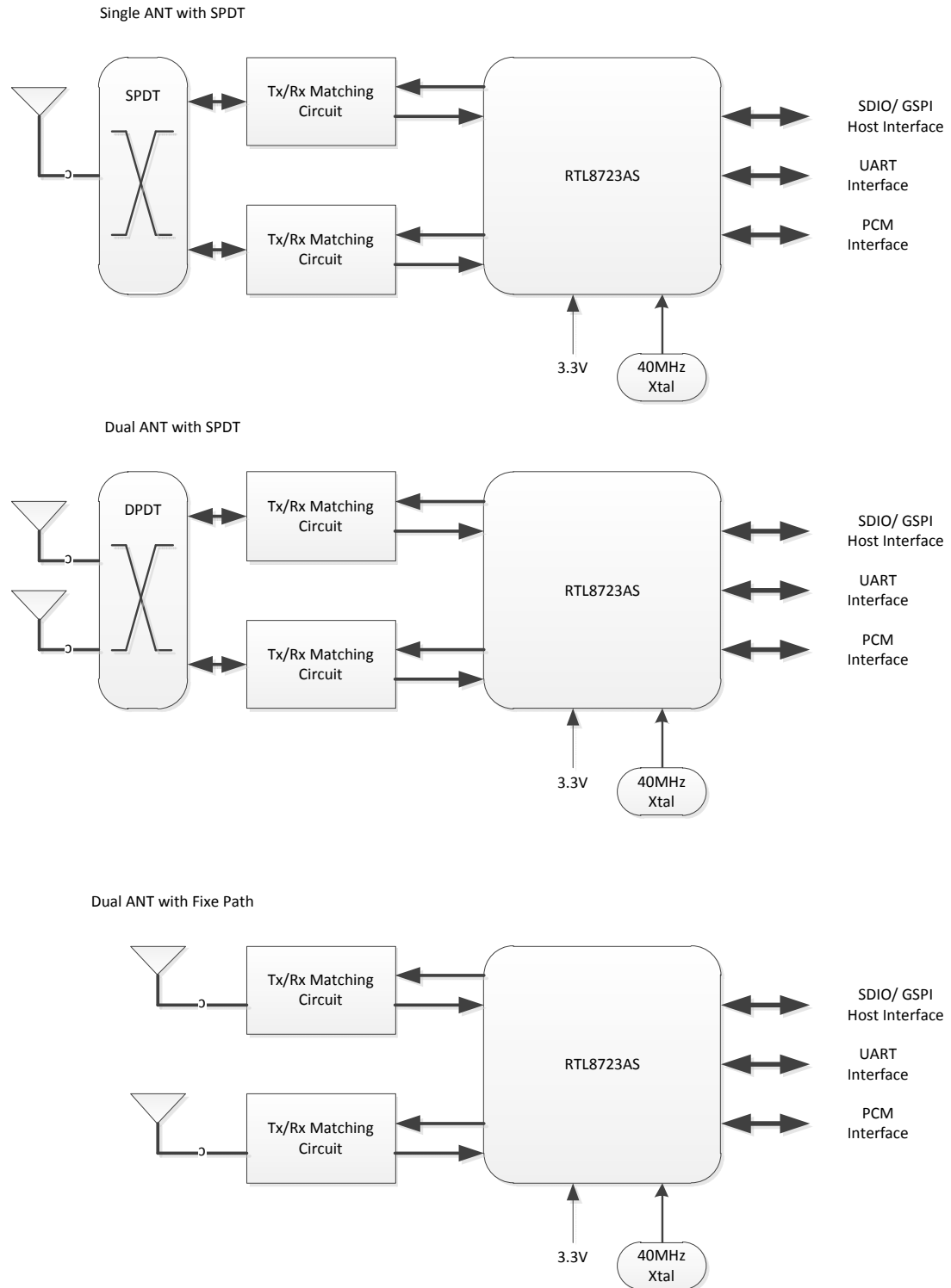

3 General Specification

■ Module Name						
• C704S0						
WLAN Specifications						
■ Product Specification						
• WLAN Standard		IEEE 802.11BGN				
• Host interface		SDIO 1.1/ 2.0/ 3.0 for WiFi and HS-UART for Bluetooth				
• Major Chipset		Realtek RTL8723AS-CG				
• Dimensions						
		Minimum	Typical	Maximum	Unit	
	Length	9.8	10	10.2	mm	
	Width	19.8	20	20.2	mm	
	Height		TBD		mm	
	Weight		TBD		g	
• Antenna Connector		One I/O pad for RF signal port				
■ Operating Condition						
		Minimum	Typical	Maximum	Unit	
• Voltage		DC 3.3V	3.15	3.3	3.45	V
		DC 1.5V	1.425	1.5	1.575	V
		DC 1.2V	1.10	1.2	1.32	V
• Temperature			0		70	°C
• Storage temperature			-20		70	°C
• Humidity Non-Operating			10		80	%
■ Electrical Specification						
• Frequency Range		2400 – 2483.5MHz				
• Modulation		BPSK, QPSK, 16QAM, 64QAM, DBPSK, DQPSK, and CCK				
• Output power						
		Minimum	Typical	Maximum	Unit	
802.11b Mode	11Mbps	13	15	17	dBm	
802.11g Mode	54Mbps	11	13	15	dBm	
802.11n Mode	HT20-MCS7	9	11	13	dBm	
802.11n Mode	HT40-MCS7	9	11	13	dBm	
• Receiver Sensitivity						
2.4GHz						
		Minimum	Typical	Maximum	Unit	
802.11g Mode	54Mbps			-70	dBm	
802.11n Mode	HT20 MCS7			-64	dBm	
802.11n Mode	HT40 MCS7			-61	dBm	

Bluetooth Specifications	
Radio Standard	Bluetooth V4.0+BLE, V3.0+HS and V2.1+EDR
Frequency Band	2400-2483.5 MHz
Data Rate	Up to 3Mbps
Channel	79 sub-channels
Transmission	FHSS (Frequency Hopping Spread Spectrum)
Modulation	GFSK@1Mbps, $\pi/4$ DQPSK@2Mbps, 8DPSK@3Mbps
Antenna Type	UF.L Antenna connector support
Output Power	Class II; -6~+4dBm
Receiver Sensitivity	-70 dBm @ BER<0.1%

4 Power Consumption

RTL8723AS WiFi Power Consumption (Test with Battery power)		
Mode 3.3V	power consumption (mA)	THP (Mbps)
WiFi Reset	0.05	-----
Non-Associated	0.08	-----
Assicuated Idle	0.83	-----
Radio off	0.08	-----
Tx n mode 40MHz	147	45
Rx n mode 40MHz	125	47
Tx n mode 20MHz	120	43.9
Rx n mode 20MHz	115	46.1
Tx g Mode	135	26.4
Rx g mode	120	23
Tx b mode	138	5.2
Rx b mode	128	5.4

RTL8723AS BT Power Consumption (Test with Battery power)		
Mode 3.3V	Power Consumption (mA)	THP (Mbps)
BT Reset	0.712	-----
Sniff	1.3	
Page/ Inquiry Scan	1.9	-----
ACL No TX	15	-----
ACL FTP	42.3(Tx) 42(Rx)	TX:921KBps (H4) RX:920KBps (H4)
SCO HV1	43	
SCO HV3	24.5	
eSCO EV3	25	
eSCO EV5	24	

5 Mechanical Dimensions

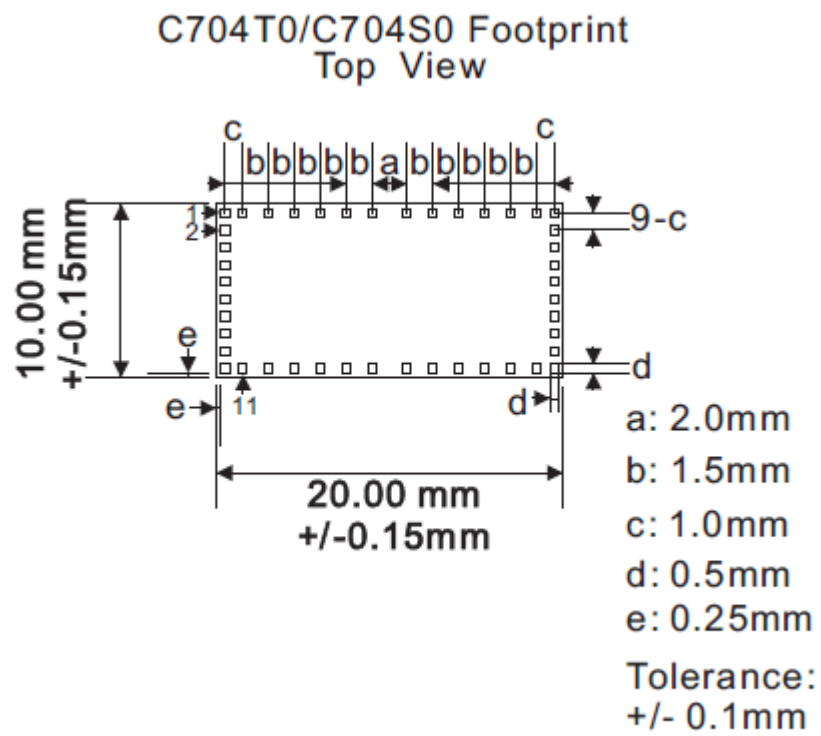

6 Connector Pin-out Definitions

Pin	Definition	Type	Description
1	GND	P	Ground.
2	GND	P	Ground.
3	RF1	RF	RF I/O port
4	GND	P	Ground.
5	RF0	RF	RF I/O port
6	GND	P	Ground.
7	RF2	RF	RF I/O port
8	GND	P	Ground.
9	VDD33	P	DC 3.3V input
10	GND	P	Ground.
11	BT_PCM_CLK	I/O	PCM Clock
12	BT_PCM_SYNC	O	PCM Sync
13	BT_PCM_OUT	O	PCM Out
14	BT_PCM_IN	I	PCM Input
15	WF_WAKEUP	O	This pin is for WIFI function to wakeup host when remote wake function is enabled. The Polarity can be defined by customer
16	BT_DISn	I	This Pin Can Externally Shutdown the RTL8723AS (no requirement for Extra Power Switch) when WL_DISn is pulled low. This pin can also support the BT Radio-off function with host interface remaining connected.
17	GND	P	Ground.
18	WL_DISn	I	This Pin Can Externally Shutdown the RTL8723AS (no requirement for Extra Power Switch) when BT_DISn is pulled low This pin can also support the WLAN Radio-off function with host interface remaining connected.
19	UART_IN	I	High-Speed UART Data IN
20	UART_RTS	O	High-Speed UART RTS
21	UART_CTS	I	High-Speed UART CTS
22	UART_OUT	O	High-Speed UART Data Out
23	GND	P	Ground.
24	UART_VDIO	P	VDD for UART Pin, the power supply is same as the signal level of UART bus (3.3V ~ 1.8V)

Pin	Definition	Type	Description
25	SD_D1	I/O	SDIO Data Line 1
26	SD_D0	I/O	SDIO Data Line 0
27	SD_CLK	I	SDIO Clock Input
28	SD_CMD	I/O	SDIO Command Input
29	SD_D3	I/O	SDIO Data Line 3
30	SD_D2	I/O	SDIO Data Line 2
31	SD_VDIO	P	VDD for SDIO Pin, the power supply is same as the signal level of SDIO bus (3.3V ~ 1.8V)
32	GND	P	Ground.
33	INT_VDD15	P	Internal 1.5V output.
34	VDD33_SPS	P	DC 3.3V input
35	INT_VDD12	P	Internal Analog 1.2V output.
36	LED	O	LED Pins (Active Low)
37	LED_BT	O	LED Pins (Active Low)
38	LED_WL	O	LED Pins (Active Low)
39	GND	P	Ground.
40	GND	P	Ground.
41	GND	P	Ground.
42	GND	P	Ground.
43	EEPROM_SEL	I	Power on value="0" for internal NV memory select
44	GND	P	Ground.

P: Power/Ground; I: Input; O: Output; RF: RF port

7 RF I/O Port Definitions

Mode	RF0	RF1	RF2
Single ANT w' SPDT	RF	NC	NC
Dual ANT w' DPDT	NC	WLAN/ BT	WLAN/ BT
Dual ANT w' fixed-path	NC	BT	WLAN