

November 2000

**OBSOLETE PRODUCT
NO RECOMMENDED REPLACEMENT**
contact our Technical Support Center at
1-888-INTERSIL or www.intersil.com/tsc

Voltage Regulator Control Circuit for Variable Switching Regulator

Features

- Operates up to 200kHz
- Pins ESD Protected
- Remote ON/OFF
- Slow Start with Reset
- Overcurrent Sensing
- Lower Peak Currents than PWM Regulator
 - Less Prone to Magnetic Saturation

Description

The CA1523 monolithic silicon integrated circuit is a variable interval pulse regulator designed to provide the control circuitry for use in switching regulator circuits. It operates from 11V to 15V.

The regulator provides a single output drive capable of 300mA source/200mA sink. The maximum operating frequency is better than 200kHz. An attractive feature of the CA1523 is that the timing capacitor charge and discharge current is set up externally via a single resistor. The ratio of charge to discharge current is internally set at a maximum of 2 to 1 allowing simultaneous change in output pulse width with increased frequency at higher load. The pulse width variation at higher frequencies effectively compensates for the losses in magnetics and thereby increases the power supply efficiency at higher load end by as much as 20 percent.

Part Number Information

PART NUMBER	TEMPERATURE RANGE	PACKAGE
CA1523E	0°C to +70°C	14 Lead Plastic DIP

Pinout

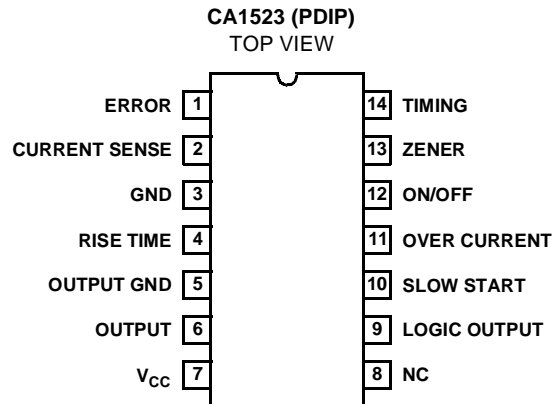

Specifications CA1523

Absolute Maximum Ratings

DC Supply Voltage	15V
Supply Current	
$I_{6(MAX)}$	$\pm 50\text{mA}$
$I_{6(MAX)}$, 1 μs , 1800pF Load	+300, -200mA
Device Dissipation	
Up to $T_A = 70^\circ\text{C}$	530mW
Above $T_A = 70^\circ\text{C}$	Derate Linearly at 6.7mW/ $^\circ\text{C}$

Thermal Information

Thermal Resistance	θ_{JA}
Plastic DIP Package	120 $^\circ\text{C}/\text{W}$
Device Dissipation	
Up to $T_A = 70^\circ\text{C}$	665mW
Ambient Temperature Range	
Operating	0 $^\circ\text{C}$ to +70 $^\circ\text{C}$
Storage	-55 $^\circ\text{C}$ to +150 $^\circ\text{C}$
Lead Temperature (During Soldering)	
At distance 1/16 \pm in. (1.59mm \pm 0.79mm)	
from case for 10s Max	+265 $^\circ\text{C}$

CAUTION: Stresses above those listed in "Absolute Maximum Ratings" may cause permanent damage to the device. This is a stress only rating and operation of the device at these or any other conditions above those indicated in the operational sections of this specification is not implied.

Electrical Specifications $T_A = +25^\circ\text{C}$, Refer to condition shown in test circuit; $V_7 = 13\text{V}$, $V_1 = 5.9\text{V}$ Unless Otherwise Specified

PARAMETERS	PIN	TEST CONDITIONS	MIN	TYP	MAX	UNITS
POWER SUPPLY, V_{CC} (PIN 7)						
Supply Voltage	7		9.5	13	-	V
Supply Current	7	$V_{CC} = +13\text{V}$	20	27	34	mA
Zener Voltage	13		7.8	8.4	8.9	V
OUTPUT PULSE (PIN 6)						
Maximum Pulse Width	6	Measured at 6V Threshold Level	5.5	6.5	7.5	μs
Minimum Pulse Width	6	Measured at 6V Threshold Level	2	3	4	μs
Output High Voltage	6	$I_6 = 0\text{mA}$, $V_4 = 0\text{V}$	11.1	12	12.6	V
Output Low Voltage	6	$I_6 = 50\text{mA}$, $V_{12} = 0\text{V}$	0.6	1	1.3	V
Rise Time	6	Measured at 1.8V and 10V Threshold Levels	250	600	1250	ns
Fall Time	6	Measured at 1.8V and 10V Threshold Levels	50	200	350	ns
ERROR VOLTAGE RANGE (PIN 1)						
Error Voltage Reference	1	Adjust R_T ; Observe Pin 6 Min/Max Frequency Range	5.9	6.8	7.5	V
CHARGE CURRENT (PIN 14)						
Charge Current	14	Adjust R_T , $V_1 = 7.5\text{V}$; Set $V_{14} = 0\text{V}$, Then $V_{14} = 2.5\text{V}$	190	220	250	μA
Discharge Current	14	Adjust $R_T = 5.9\text{V}$; Set $V_{14} = 5.5\text{V}$, Then 5V	95	110	125	μA
Slow Start Discharge Current	14	Maintain $V_{14} = 5\text{V}$, $V_{10} = 5.5\text{V}$ Set $V_{10} = 5.5\text{V}$, Measure I_{14} (Hi) Set $V_{10} = 4\text{V}$, Measure I_{14} (Lo) Limits = I_{14} (Hi) - I_{14} (Lo) 1.5	20	30	40	$\mu\text{A/V}$
LOGIC TESTS						
Discharge Voltage	10	Pin 12 = 1k Ω to GND	1.7	2.4	3.2	V
Output Inhibit Voltage	7	Increase V_7 Until $V_9 \geq 2\text{V}$	7.9	8.4	9.1	V
Overcurrent Trip Voltage	11	$V_{12} = 5\text{V}$; $V_{10} = 0\text{V}$; Increase V_{11} Until $V_9 \leq 0.5\text{V}$	1.1	1.25	1.4	V

Other Desirable Features

Other desirable features along with various circuit block function explanations are listed below.

- The **Oscillator** is a sawtooth generator whose charge (rise) cycle determines the output pulse width and discharge which is continuously variable from very low to maximum of I_{CHARGE} .
- Charge $I_{CHARGE} = I_O - I_{DISCHARGE}$ giving 2 to 1 pulse-width control
- Discharge $I_{DISCHARGE} =$ approximately 0 to 1/2 I_O to frequency control.
- **Pulse Shaping:** Applied to the oscillator output via RS Flip-Flop with parallel inhibit controlled by slow-start over-current sense, supply voltage monitor and ON/OFF functions.
- **Pulse Rise Time:** Modified to meet RFI requirements by external slow-down capacitor.
- **Slow Start with Reset:** Externally programmed against internal 3V reference. Reset is initiated upon Inhibit ensuring soft start at power up and restart.
- **Over Current Sense:** Internal stable thresholds of 1.2V.
- **Supply Voltage Monitors:** Locks out the drive until V_{SUPPLY} has reached 8V-9V.
- **ON/OFF:** Activates regulator independent of raw DC.
- **Error Amplifier:** Compares output against a stable 6.8V internal reference and controls the discharge current sink on the timing capacitor.
- **Band-Gap:** Reference voltage (internal) provides temperature compensated 1.2V and 6.8V references.
- **Separate GND:** The power GND is separated from circuit ground for improved noise.
- **ESD Protection:** Pins are protected against ESD.

Block Diagram

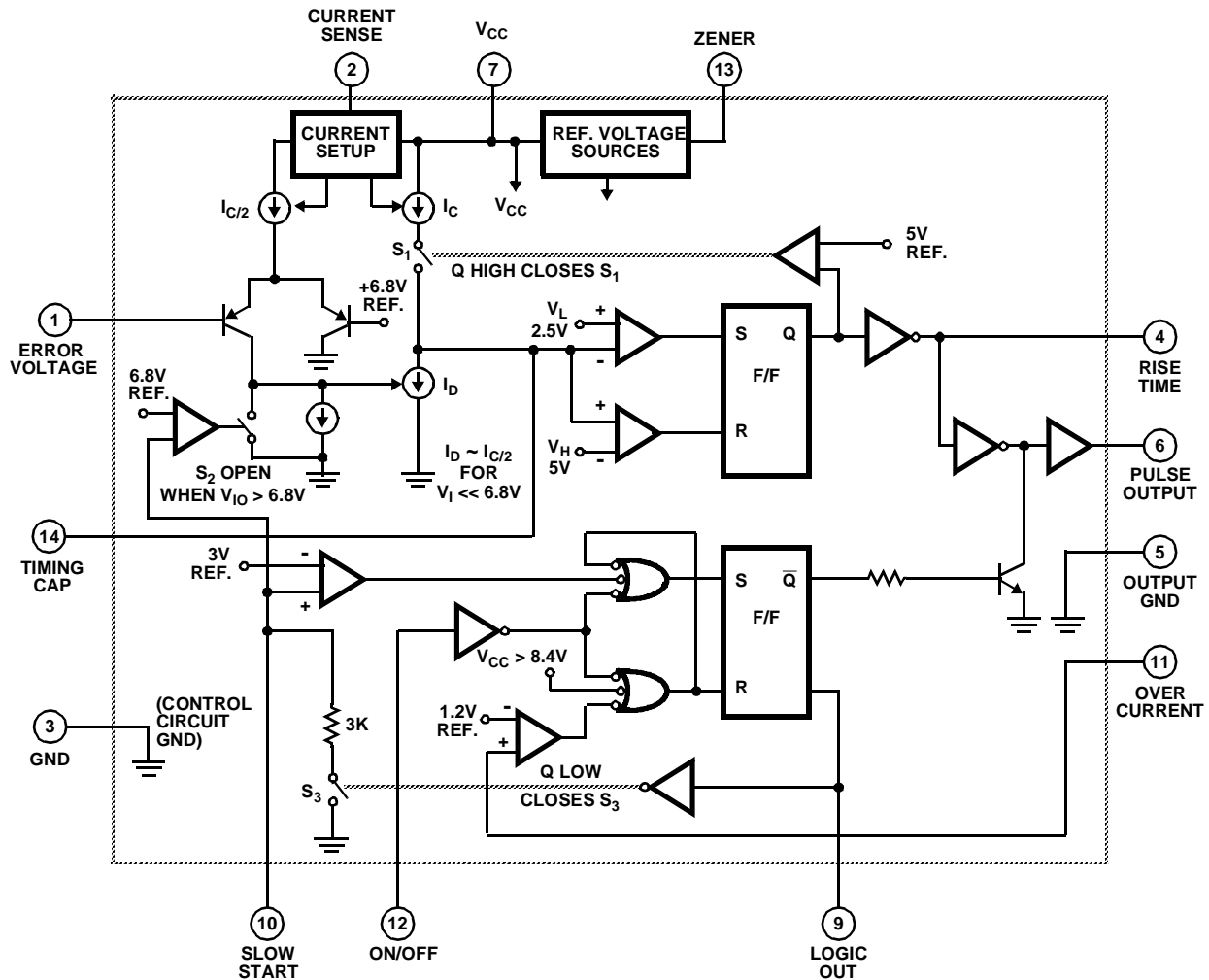

CA1523

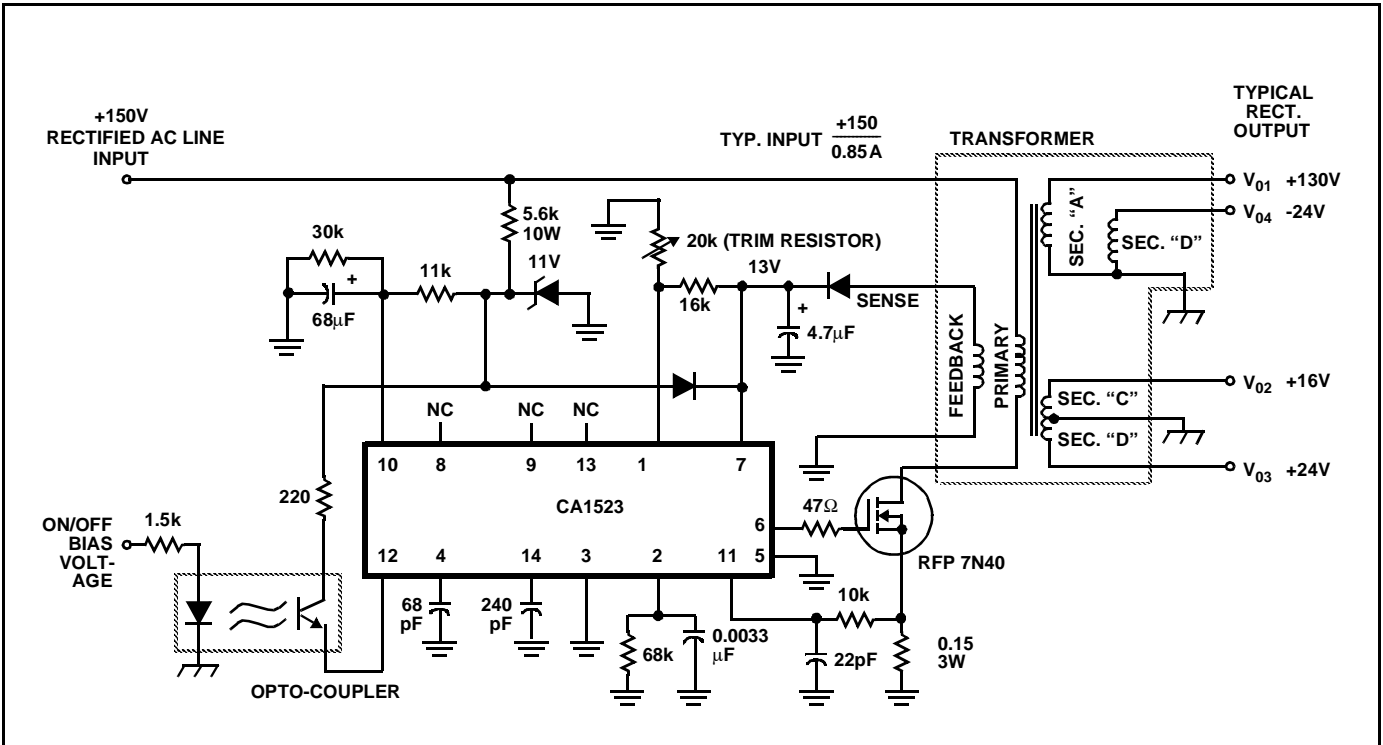

FIGURE 2. TYPICAL APPLICATION CIRCUIT FOR THE CA1523

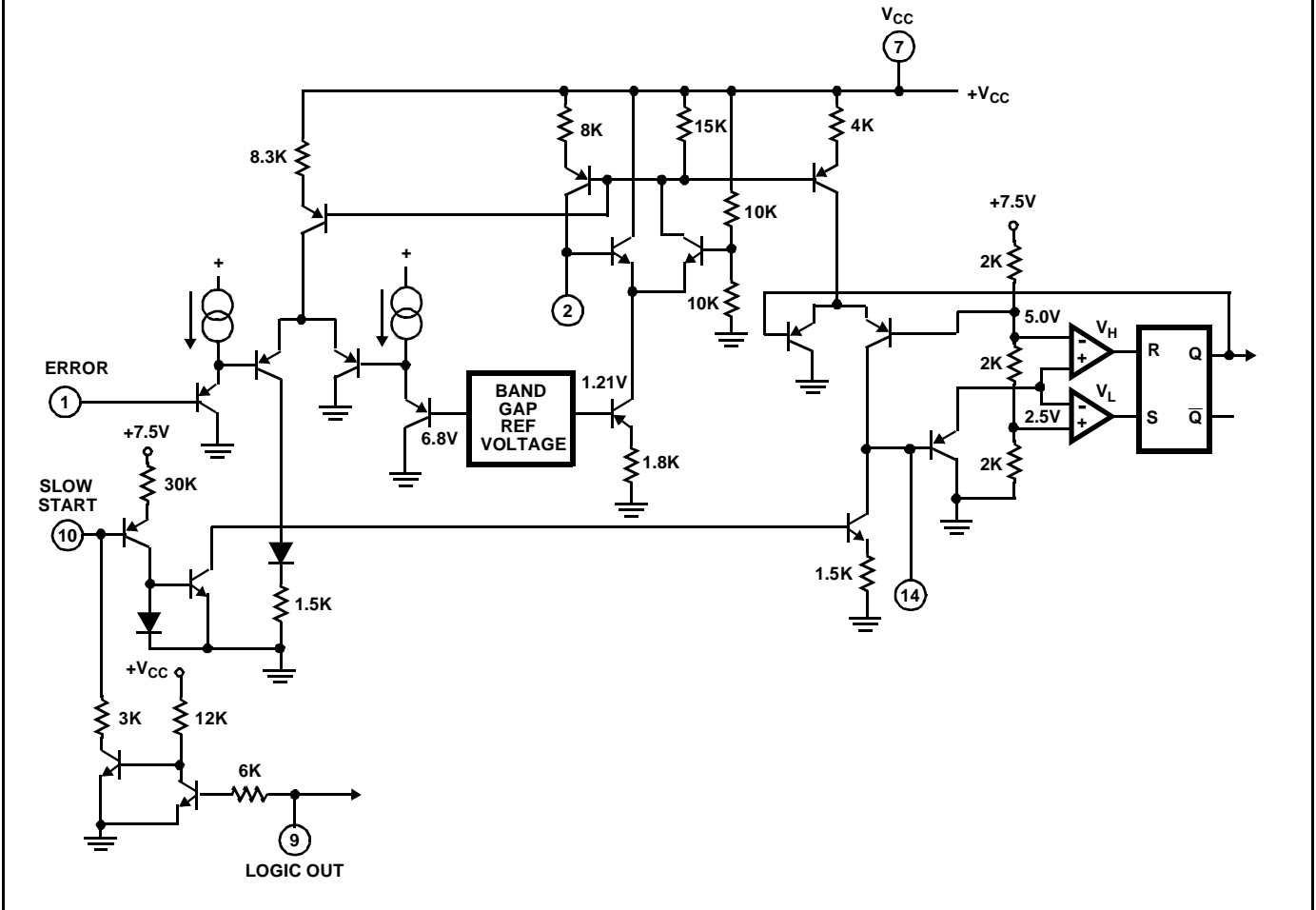

FIGURE 3. TIMING CIRCUIT FOR THE CA1523

