

May 1990

### Quad BiMOS Operational Amplifiers

With MOSFET Input, Bipolar Output

**Features:**

- Internally compensated
- MOSFET Input Stage
  - (a) Very high input impedance ( $Z_{IN}$ ): 1.5 T $\Omega$  typ.
  - (b) Very low input current ( $I_I$ ): 10 pA typ. at  $\pm 15$  V
  - (c) Wide common-mode input voltage range ( $V_{ICR}$ ): can be swung to the negative supply voltage rail
  - (d) Rugged input stage: bipolar diode protected
- Directly replaces industry type 324 in most applications
- Operation from 6-to-36 volts single or dual supplies
- Characterized for  $\pm 15$ -volt operation and for TTL supply systems with operation down to 6 volts
- Wide bandwidth: 5 MHz unity gain at  $\pm 15$  V or a single 30 V supply
- High voltage follower slew rate: 10 V/ $\mu$ s

**Applications:**

- Ground referenced single supply amplifiers in automobile and portable instrumentation
- Sample and hold amplifiers
- Long duration timers/multivibrators (microseconds-minutes-hours)
- Photocurrent instrumentation
- Active filters
- Intrusion alarm systems
- Comparators
- Instrumentation amplifiers
- Function generators
- Power supplies

The CA3410A and CA3410 are BiMOS integrated circuit operational amplifiers. They combine the advantage of MOS and bipolar transistors on the same monolithic chip. The gate-protected MOSFET (PMOS) input transistors provide high input impedance and a wide common-mode input voltage range (typically to the negative supply rail). The bipolar output transistors allow a wide output voltage swing and provide a high output current capability.

The CA3410A and CA3410 are supplied in the 14-lead dual-in-line plastic package (E suffix). They are pin-compatible with the industry standard 324 and 084 operational amplifiers in similar packages. The CA3410A and CA3410 have an operating temperature range of  $-40$  to  $+85^\circ\text{C}$ .

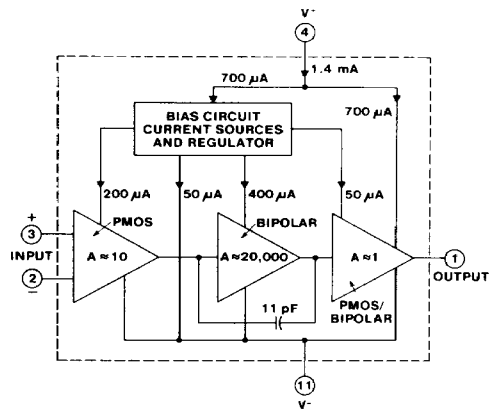

Figure 1 - Block diagram of 1/4 of the CA3410E.

# CA3410A, CA3410

## MAXIMUM RATINGS, Absolute-Maximum Values:

DC SUPPLY VOLTAGE (BETWEEN V <sup>+</sup> AND V <sup>-</sup> TERMINALS)	36 V
OPERATING VOLTAGE RANGE	6 to 36 V or $\pm 2$ to $\pm 18$ V
DIFFERENTIAL-MODE INPUT VOLTAGE	$\pm 16$ V
COMMON-MODE DC INPUT VOLTAGE	(V <sup>+</sup> +8 V) to (V <sup>-</sup> -0.5 V)
INPUT-TERMINAL CURRENT	0.1 mA
DEVICE DISSIPATION:	
UP TO 55°C	625 mW
ABOVE 55°C	Derate linearly 6.67 mW/°C
TEMPERATURE RANGE:	
OPERATING	-40 to +85°C
STORAGE	-65 to +150°C
OUTPUT SHORT-CIRCUIT DURATION*	UNLIMITED
LEAD TEMPERATURE (DURING SOLDERING):	
AT DISTANCE 1/16 $\pm$ 1/32 INCH (1.59 $\pm$ 0.79 MM)	
FROM CASE FOR 10 SECONDS MAX.	+265°C

\*Short circuit may be applied to ground or to either supply. Temperatures and/or supply voltages must be limited to keep dissipation within maximum rating.

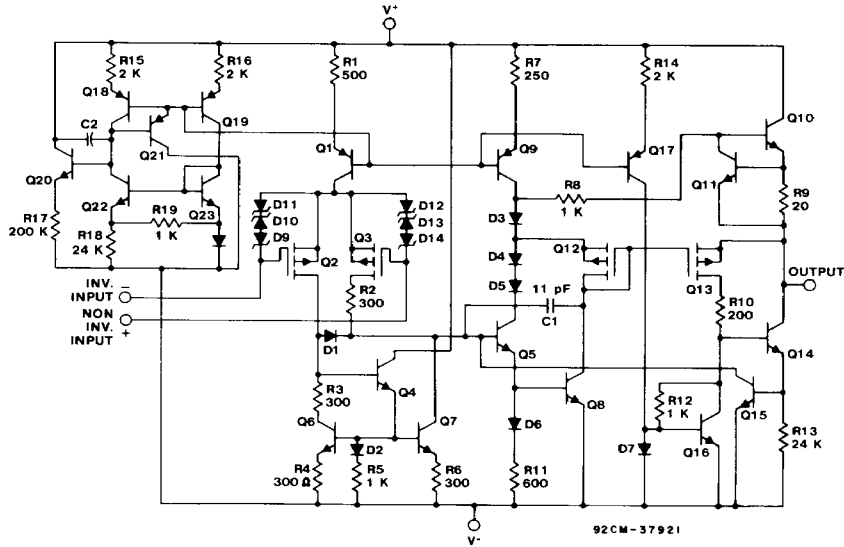

Fig. 2 - Schematic diagram for 1/4 of the CA3410.

### Circuit Description

The schematic diagram of one amplifier section of the CA3410 is shown in Fig. 2. It consists of a differential amplifier stage using PMOS transistors Q2 and Q3 with gate-to-source protection against static discharge damage provided by zener diodes D9, D10, D11, and D12. Constant current bias is applied to the

differential amplifier from transistors Q1 connected as a constant-current source. This assures a high common-mode rejection ratio. The output of the differential amplifier is coupled to the base of gain stage transistors Q5 and Q8 by means of an n-p-n current mirror that supplies the required differential-to-single-ended conversion.

# CA3410A, CA3410

**ELECTRICAL CHARACTERISTICS for Equipment Design at  $V^+ = 15\text{ V}$ ,  $V^- = 15\text{ V}$ ,  $T_A = 25^\circ\text{C}$  Unless Otherwise Specified**

CHARACTERISTIC		LIMITS						UNITS
		CA3410A			CA3410			
		Min.	Typ.	Max.	Min.	Typ.	Max.	
Input Offset Voltage	$V_{IO}$	—	3	8	—	8	15	mV
Input Offset Current	$I_{IO}$	—	0.5	10	—	0.5	30	pA
Input Current	$I_I$	—	10	30	—	10	40	pA
Large-Signal Voltage Gain $R_L = 2\text{ k}\Omega$	$A_{OL}$ $V_O = \pm 10\text{ V}$	20 k	100 k	—	20 k	100 k	—	V/V
		86	100	—	86	100	—	dB
Common-Mode Rejection Ratio	CMRR	—	32	100	—	32	320	$\mu\text{V/V}$
		80	90	—	70	90	—	dB
Common-Mode Input-Voltage Range	$V_{ICR}$	-15	-15.5	12.5	-15	-15.5	12.5	V
			to 13		to 13			
Power-Supply Rejection Ratio	$\Delta V_{IO}/\Delta V$ PSRR	—	50	100	—	50	316	$\mu\text{V/V}$
		80	86	—	70	86	—	dB
Maximum Output Voltage Swing $R_L = 2\text{ k}\Omega$	$V_{OM}^+$ $V_{OM}^-$	13	13.9	—	13	13.9	—	V
		-10.5	-11.2	—	-10.5	-11.2	—	
Maximum Output Voltage Swing $R_L = 10\text{ k}\Omega$	$V_{OM}^+$ $V_{OM}^-$	13.5	14.2	—	13.5	14.2	—	V
		-11	-12.2	—	-11	-12.2	—	
Total Supply Current	$I^+$	—	8	10	—	8	12	mA
Total Device Dissipation	$P_D$	—	240	300	—	240	360	mW

## Circuit Description (Cont'd)

### Output Stage

The output stage is a physio-complementary amplifier with n-p-n output transistors. Diode D3 complements Q10, while diode connected PMOS transistor Q12 complements PMOS transistor Q13. N-P-N transistor Q14 provides the sinking current while n-p-n transistor Q10 provides the sourcing current.

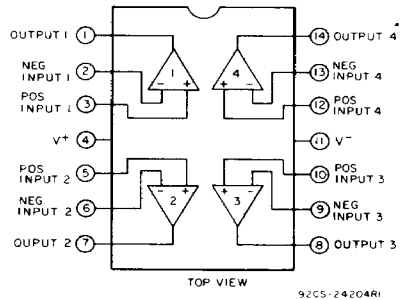

Fig. 3 - Functional diagram.

# CA3410A, CA3410

## TYPICAL ELECTRICAL CHARACTERISTICS

CHARACTERISTIC		TEST CONDITIONS $V^+ = 15\text{ V}$ $V^- = -15\text{ V}$ $T_A = 25^\circ\text{ C}$	TYPICAL VALUES		UNITS
			CA3410A	CA3410	
Input Resistance	$R_i$		1.5	1.5	$T\Omega$
Input Capacitance	$C_i$		4	4	pF
Output Resistance	$R_o$		60	60	$\Omega$
Equivalent Wideband Input Noise Voltage	$e_n$	BW = 140 kHz $R_s = 1\text{ M}\Omega$	48	48	$\mu\text{V}$
Equivalent Input Noise Voltage	$e_n$	f = 1 kHz	$R_s = 100\ \Omega$	40	nV/ $\sqrt{\text{Hz}}$
		f = 10 kHz		30	
Short-Circuit Current to Opposite Supply	Source $I_{OM}^+$		35	35	mA
	Sink $I_{OM}^-$		17	17	
Gain-Bandwidth Product	$f_T$		5.4	5.4	MHz
Slew Rate	SR		10	10	V/ $\mu\text{s}$
Transient Response:					
Rise Time:	$t_r$	$R_L = 2\text{ k}\Omega$	0.08	0.08	$\mu\text{s}$
Overshoot		$C_L = 100\text{ pF}$	10	10	%
Crosstalk		f = 1 kHz	120	120	dB

**3**  
OPERATIONAL AMPLIFIERS

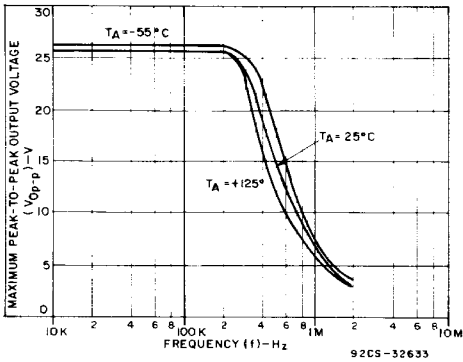

Fig. 4 - Output voltage as a function of frequency and temperature.

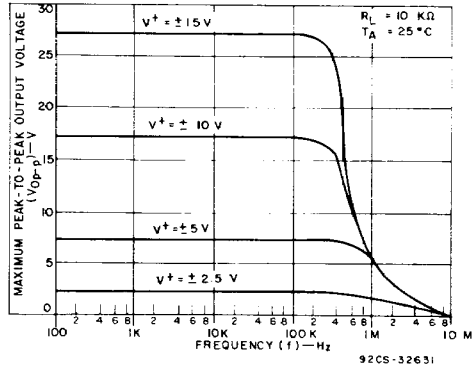

Fig. 5 - Output voltage as a function of frequency and supply voltage.

# CA3410A, CA3410

**ELECTRICAL CHARACTERISTICS for Equipment Design at  $V^+ = 15\text{ V}$ ,  $V^- = 15\text{ V}$ ,  $T_A = -40\text{ to }100^\circ\text{C}$   
Unless Otherwise Specified**

CHARACTERISTIC		TYPICAL VALUES		UNITS
		CA3410A	CA3410	
Input Offset Voltage	$V_{IO}$	4	10	mV
Input Offset Current	$I_{IO}$	8	10	mA
Input Current	$I_I$	10	20	mA
Large-Signal Voltage Gain $R_L = 2\text{ k}\Omega$	$A_{OL}$	50 k	50 k	V/V
	$V_O = \pm 10\text{ V}$	94	94	dB
Common-Mode Rejection Ratio	CMRR	32	32	$\mu\text{V/V}$
		90	90	dB
Common-Mode Input-Voltage Range	$V_{ICR}$	-15	-15	V
		to	to	
		+12.50	+12.50	
Power-Supply Rejection Ratio	$\Delta V_{IO}/\Delta V$	150	150	$\mu\text{V/V}$
	PSRR	76	76	dB
Maximum Output Voltage $R_L = 2\text{ k}\Omega$	$V_{OM}^+$	13.50	13.50	V
	$V_{OM}^-$	-10.50	-10.50	
Supply Current	$I^+$	9	10	mA
Total Device Dissipation	$P_D$	270	300	mW
Temperature Coefficient of Input Offset Voltage	$\Delta V_{IO}/\Delta T$	10	12	$\mu\text{V}/^\circ\text{C}$

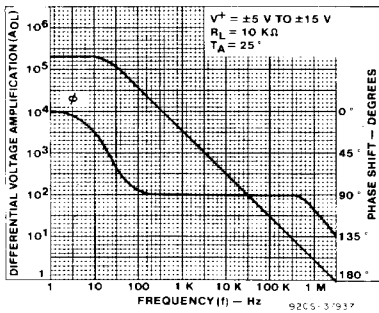

Fig. 6 - Differential voltage amplification as a function of frequency.

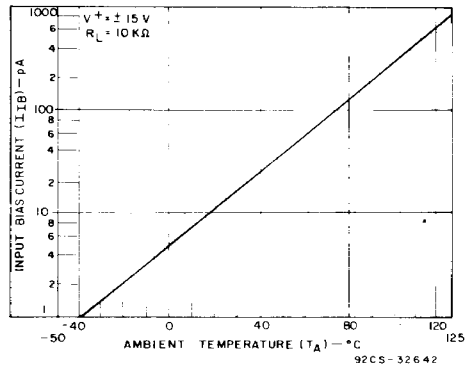

Fig. 7 - Input bias current as a function of ambient temperature.

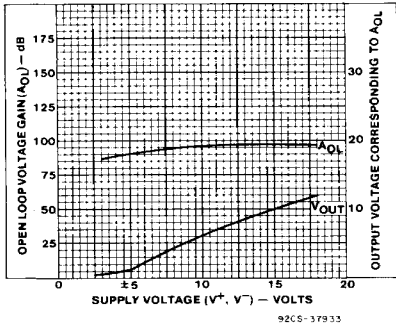

Fig. 8 - Open-loop voltage gain as a function of supply voltage and output voltage.

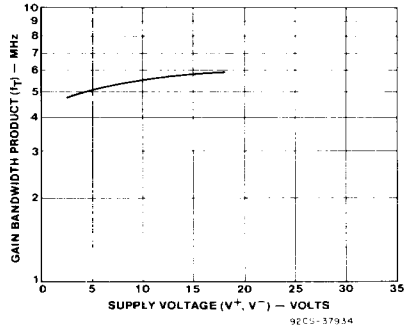

Fig. 9 - Gain-bandwidth product as a function of supply voltage.

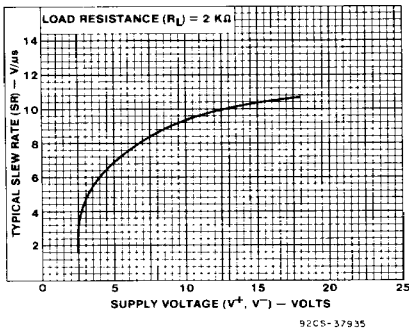

Fig. 10 - Slew rate as a function of supply voltage.

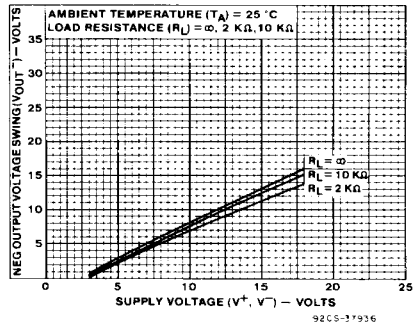

Fig. 11 - Negative output voltage swing as a function of supply voltage.

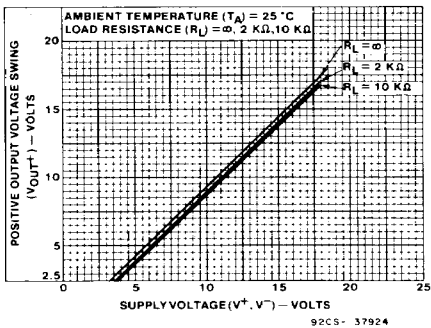

Fig. 12 - Positive output voltage swing as a function of supply voltage.

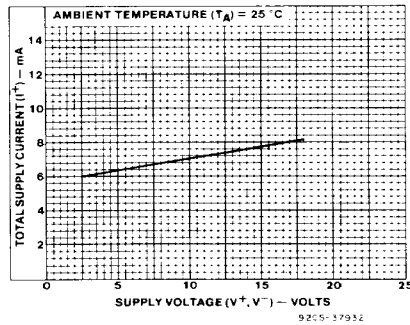

Fig. 13 - Total supply current as a function of supply voltage.

# CA3410A, CA3410

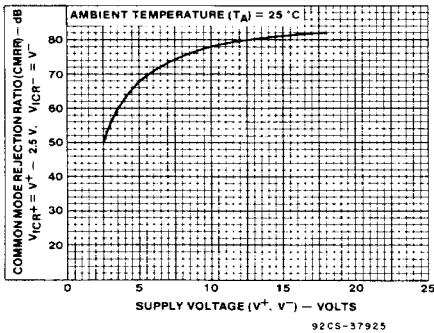

Fig. 14 - Typical common-mode rejection ratio as a function of supply voltage.

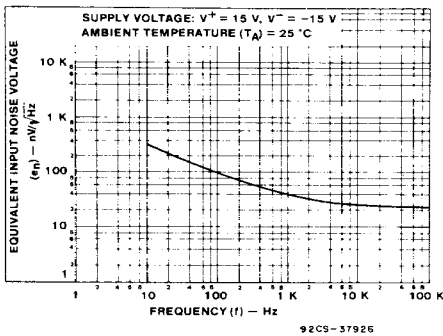

Fig. 15 - Equivalent input noise voltage as a function of frequency.

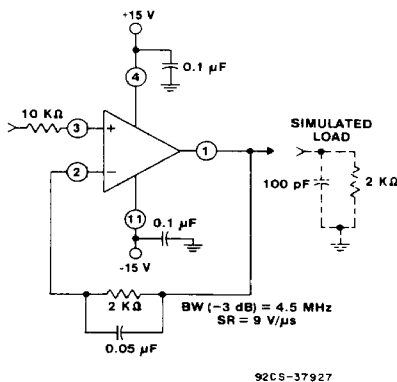

Fig. 16 - Split-supply voltage-follower test circuit.

## APPLICATIONS CONSIDERATIONS

### Input Circuit Considerations

As indicated by the typical VICR, this device will accept inputs as low as  $V^-$ . However, a series current-limiting resistor is recommended to limit the maximum input terminal current to less than 1 mA to prevent damage to the input protection circuitry.

Moreover, some current-limiting resistance should be provided between the inverting input and the output when the CA3410 is used as a unity-gain voltage follower. This resistance prevents the possibility of extremely large input-signal transients from forcing a signal through the input-protection network and directly driving the internal constant-current source which could result in positive feedback via the output terminal. A 3.9-kΩ resistor is sufficient.

The typical input current is in the order of 10 pA when the inputs are centered at nominal device dissipation. As the output supplies load current, device dissipation will increase, raising the chip temperature and resulting in increased input current.

It is well known that MOSFET devices can exhibit slight changes in characteristics (for example, small changes in input offset voltage) due to the application of large differential input voltages that are sustained over long periods at elevated temperatures.

Both applied voltage and temperature accelerate these changes. The process is reversible and offset voltage shifts of the opposite polarity reverse the offset. In typical linear applications, where the differential voltage is small and symmetrical, these incremental changes are of about the same magnitude as those encountered in an operational amplifier employing a bipolar transistor input stage.

## TYPICAL APPLICATIONS

### On/Off Touch Switch

The on/off touch switch shown in Fig. 18 uses the CA3410E to sense small currents flowing between two contact points on a touch plate consisting of a PC board metallization "grid". When the "on" plate is touched, current flows between the two halves of the grid causing a positive shift in the output voltage (Term. 7) of the CA3410E. These positive transitions are fed into the CA3059, which is used as a latching circuit and zero-crossing triac driver. When a positive pulse occurs at Terminal 7 of the CA3410E, triac is turned on and held on by the CA3059 and its associated positive feedback circuitry (51-kΩ resistor and 36-kΩ/42-kΩ voltage divider). When the positive pulse occurs at Terminal 1 (CA3410E), the triac is turned off and held off in a similar manner. Note that power for the CA3410E is supplied by the CA3059 internal power supply.

The advantage of using the CA3410E in this circuit is that it can sense the small currents associated with skin conduction while allowing sufficiently high circuit impedance to provide protection against electrical shock.

## CA3410A, CA3410

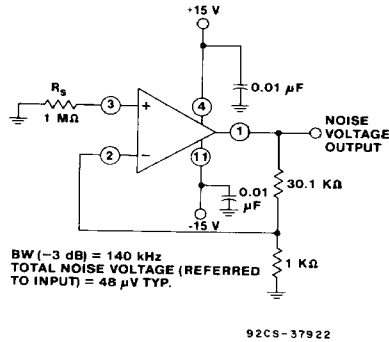

Fig. 17 - Test-circuit amplifier (30-dB gain) used for wideband noise measurement.

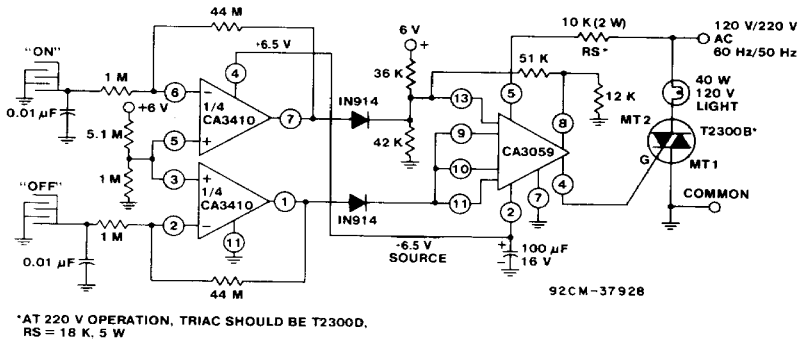

Fig. 18 - On/off touch switch.

### Dual Level Detector (window comparator)

Fig. 19 illustrates a simple dual liquid level detector using the CA3410E as the sensing amplifier. This circuit operates on the principle that most liquids contain enough ions in solution to sustain a small amount of current flow between two electrodes submersed in the liquid. The current, induced by an 0.5-V potential applied

between two halves of a PC board grid, is converted to a voltage level by the CA3410E in a circuit similar to that of the on/off touch switch in Fig. 18. The changes in voltage for both the upper and lower level sensors are processed by the amp 3 of their CA3410 to activate an LED whenever the liquid level is above the upper sensor or below the lower sensor.



## CA3410A, CA3410

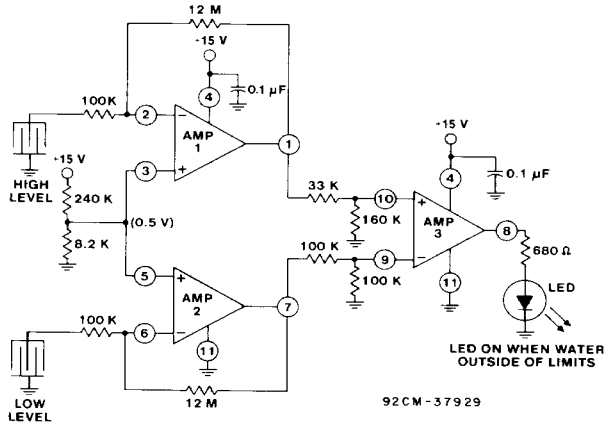
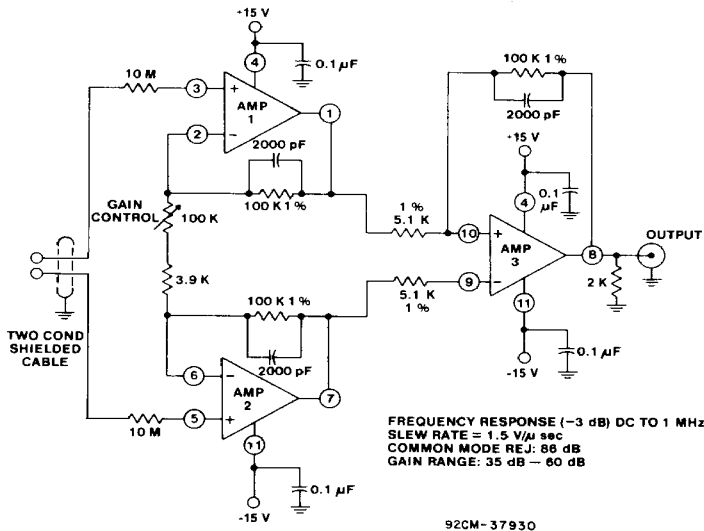

Fig. 19 - Dual level detector.

### Precision Differential Amplifier

Fig. 20 shows the CA3410 in the classical precision differential amplifier circuit. The CA3410 is ideally suited for biomedical applications because of its extremely high input impedance. To insure patient safety, an extremely high electrode series resistance is required to limit any current that might result in patient discomfort in the event

of a fault condition. In this case, 10-MΩ resistors have been used to limit the current to less than 2 μA without affecting the performance of the circuit. Fig. 21 shows a typical electrocardiogram waveform obtained with this circuit.



FREQUENCY RESPONSE (-3 dB) DC TO 1 MHz  
 SLEW RATE = 1.5 V/μ sec  
 COMMON MODE REJ: 86 dB  
 GAIN RANGE: 35 dB - 80 dB

Fig. 20 - Precision differential amplifier.

## CA3410A, CA3410

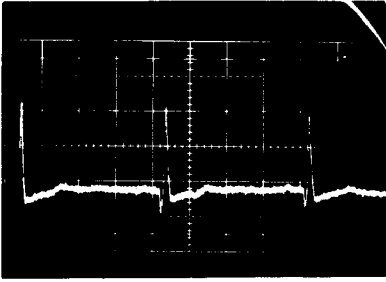

TYPICAL ELECTROCARDIOGRAM WAVEFORM

VERTICAL : 1.0 mV/DIV.  
 (AMPLIFIER GAIN = 100 X)  
 (SCOPE SENSITIVITY = 0.1V/DIV.)  
 HORIZONTAL : > 0.2 SEC/DIV (UNCAL)

92CS-30033

Fig. 21 - Typical electrocardiogram waveform.

### Differential Light Detector

In the circuit shown in Fig. 22, the CA3410E converts the current from two photo diodes to voltage, and applies 1 V of reverse bias to the diodes. The voltages from the CA3410 outputs are subtracted in the second stage

(Amp 3) so that only the difference is amplified. In this manner, the circuit can be used over a wide range of ambient light conditions without circuit component adjustment. Also, when used with a light source, the circuit will not be sensitive to changes in light level as the source ages.

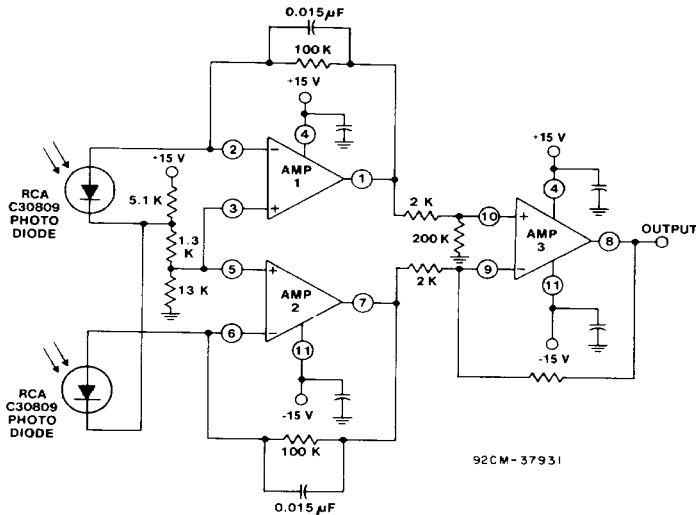

Fig. 22 - Differential light detector.