

CAR600M17HN6

1700 V, 600 A, Silicon Carbide, Half-Bridge Rectifier

V_R	1700 V
I_F	600 A

Technical Features

- Ultra-Low Loss, High Frequency Operation
- Low Forward Voltage (V_F) Drop with Positive Temperature Coefficient
- Zero Reverse Recovery Current
- Zero Forward Recovery Voltage
- Temperature-Independent Switching Behavior

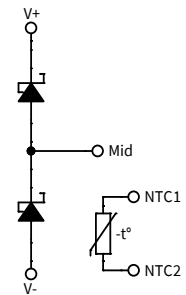

Typical Applications

- Railway, Traction, and Motor Drives
- EV Chargers
- High-Efficiency Converters/Inverters
- Renewable Energy
- Smart-Grid/Grid-Tied Distributed Generation

System Benefits

- Enables Compact, Lightweight Systems
- Increased System Efficiency, due to Low Switching & Conduction Losses of SiC
- Reduced Thermal Requirements and System Cost

Key Parameters (Verified by Design)

Parameter	Symbol	Min.	Typ.	Max.	Unit	Test Conditions	Note
Maximum Reverse Voltage	V_{R-Max}			1700	V		
Continuous Forward Current	I_F		986		A	$T_C = 25\text{ }^\circ\text{C}$, $T_{VJ} \leq 175\text{ }^\circ\text{C}$	
			702			$T_C = 90\text{ }^\circ\text{C}$, $T_{VJ} \leq 175\text{ }^\circ\text{C}$	
Maximum Pulsed Forward Current	$I_{F(Pulsed)}$			1200		t_{Pmax} Limited by T_{VJmVax} $T_C = 25\text{ }^\circ\text{C}$	
Maximum Virtual Junction Temperature	T_{VJ}	-40		175	$^\circ\text{C}$		

Diode Characteristics (Per Position) ($T_{VJ} = 25\text{ }^{\circ}\text{C}$ Unless Otherwise Specified)

Parameter	Symbol	Min.	Typ.	Max.	Unit	Test Conditions	Note
Diode Forward Voltage	V_F		1.6		V	$I_F = 600\text{ A}$	
			2.2			$I_F = 600\text{ A}, T_{VJ} = 175\text{ }^{\circ}\text{C}$	
Reverse Current	I_R		0.06		mA	$V_R = 1700\text{ V}, T_{VJ} = 25\text{ }^{\circ}\text{C}$	
			0.29			$V_R = 1700\text{ V}, T_{VJ} = 175\text{ }^{\circ}\text{C}$	
Total Capacitive Charge	Q_C		4.9		mC	$V_R = 1100\text{ V}$	
Total Capacitance	C		55.7		nF	$V_R = 0\text{ V}, f = 100\text{ kHz}$	
			2.9			$V_R = 550\text{ V}, f = 100\text{ kHz}$	
			2.7			$V_R = 1100\text{ V}, f = 100\text{ kHz}$	
Thermal Resistance, Junction to Case	R_{TH-JC}		0.048			Per position	

Note:

¹SiC Schottky diodes are majority carrier devices, so there is no reverse recovery charge.



Module Physical Characteristics

Parameter	Symbol	Min.	Typ.	Max.	Unit	Test Conditions
Package Resistance, M1 (High-Side)	R ₁₋₂		106.5		μΩ	T _c = 125 °C, Note 1
Package Resistance, M2 (Low-Side)	R ₂₋₃		126.3			T _c = 125 °C, Note 1
Stray Inductance	L _{Stray}		4.9		nH	Between DC- and DC+, f = 10 MHz
Case Temperature	T _c	-40		125	°C	
Mounting Torque	M _s	3	4.5	5	N-m	Baseplate, M6 bolts
		0.9	1.1	1.3		Power Terminals, M4 bolts
Weight	W		167		g	
Case Isolation Voltage	V _{isol}	4			kV	AC, 50 Hz, 1 minute
Comparative Tracking Index	CTI	600				
Clearance Distance		13.07			mm	Terminal to Terminal
		6.00				Terminal to Heatsink
Creepage Distance		14.27				Terminal to Terminal
		12.34				Terminal to Heatsink

NTC Characteristics (T_{NTC} = 25 °C Unless Otherwise Specified)

Parameter	Symbol	Min.	Typ.	Max.	Unit	Notes
Resistance at 25 °C	R ₂₅		4700		Ω	
Tolerance of R ₂₅			±1		%	
Beta Value for 25 °C to 85 °C	B _{25/85}		3435		K	
Beta Value for 0 °C to 100 °C	B _{0/100}		3399		K	
Tolerance of B _{25/85}			±1		%	
Maximum Power Dissipation	P _{Max}		50		mW	

Steinhart & Hart Coefficients for NTC Resistance & NTC Temperature Computation (T in K)

$$\ln\left(\frac{R}{R_{25}}\right) = A + \frac{B}{T} + \frac{C}{T^2} + \frac{D}{T^3}$$

$$\frac{1}{T} = A_1 + B_1 \ln\left(\frac{R}{R_{25}}\right) + C_1 \ln^2\left(\frac{R}{R_{25}}\right) + D_1 \ln^3\left(\frac{R}{R_{25}}\right)$$

A	B	C	D
-1.289E+01	4.245E+03	-8.749E+04	-9.588E+06

A ₁	B ₁	C ₁	D ₁
3.354E-03	3.001E-04	5.085E-06	2.188E-07

Typical Performance

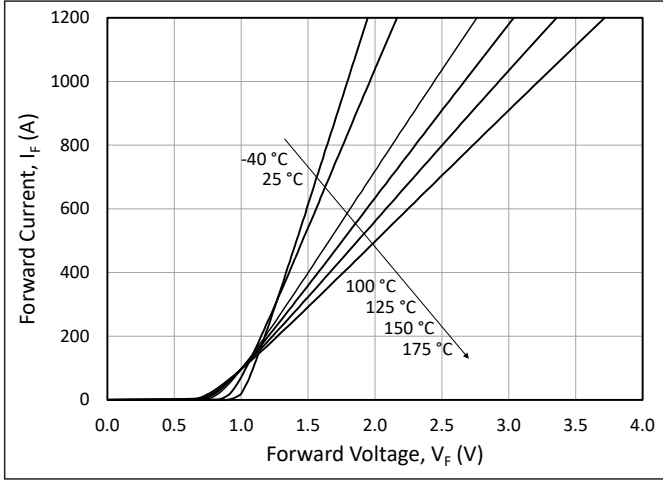

Figure 1. Typical Forward Characteristics

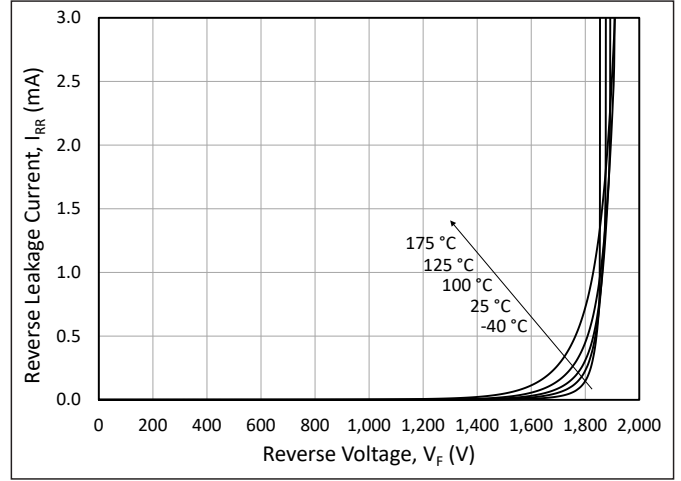

Figure 2. Typical Reverse Characteristics

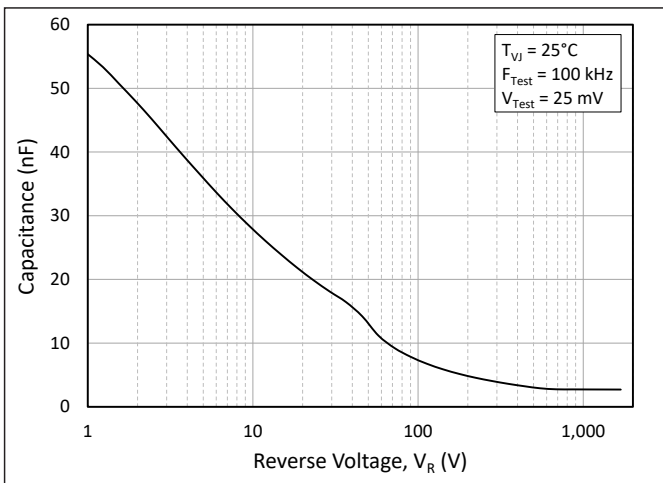

Figure 3. Typical Capacitance vs. Reverse Voltage

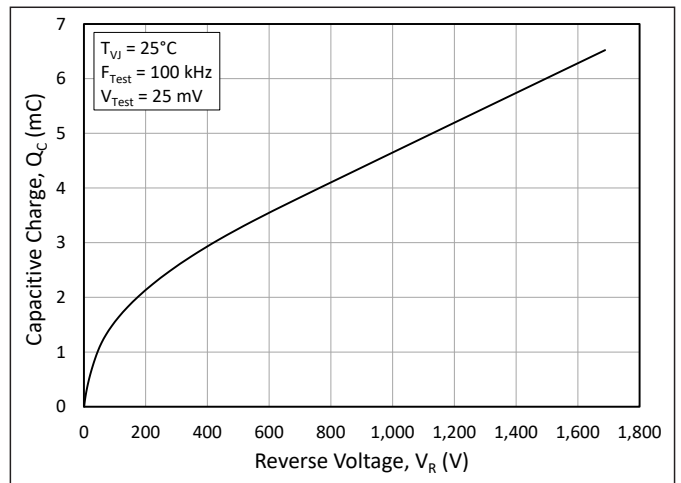

Figure 4. Typical Capacitive Charge vs. Reverse Voltage

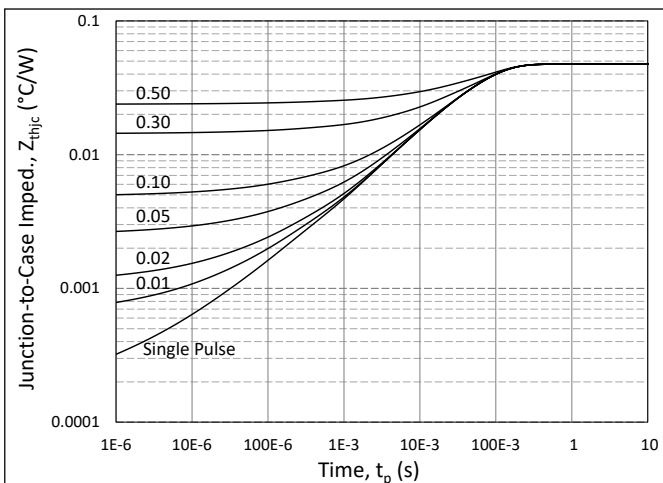

Figure 5. Diode Junction to Case Transient Thermal Impedance, Z_{thJC} (°C/W)

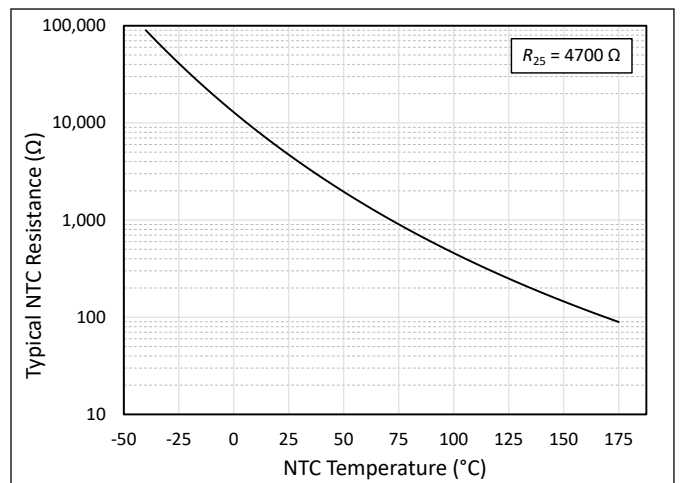
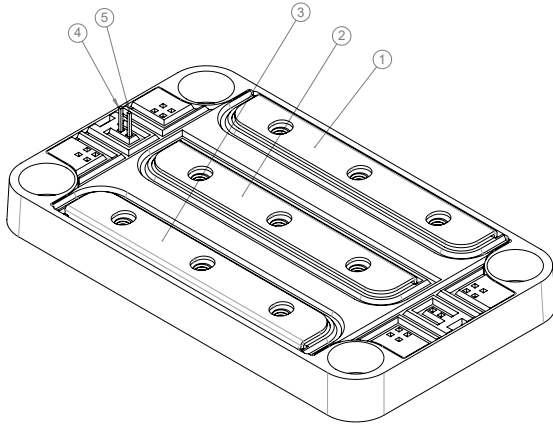

Figure 6. NTC Resistance vs. NTC Temperature



Schematic and Pin Out



PIN OUT SCHEME	
PIN	LABEL
①	V+
②	Mid
③	V-
④	NTC1
⑤	NTC2

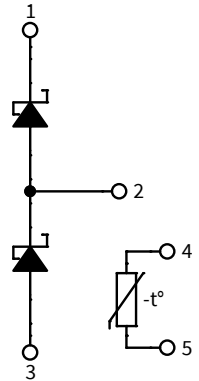

Package Dimension (mm)

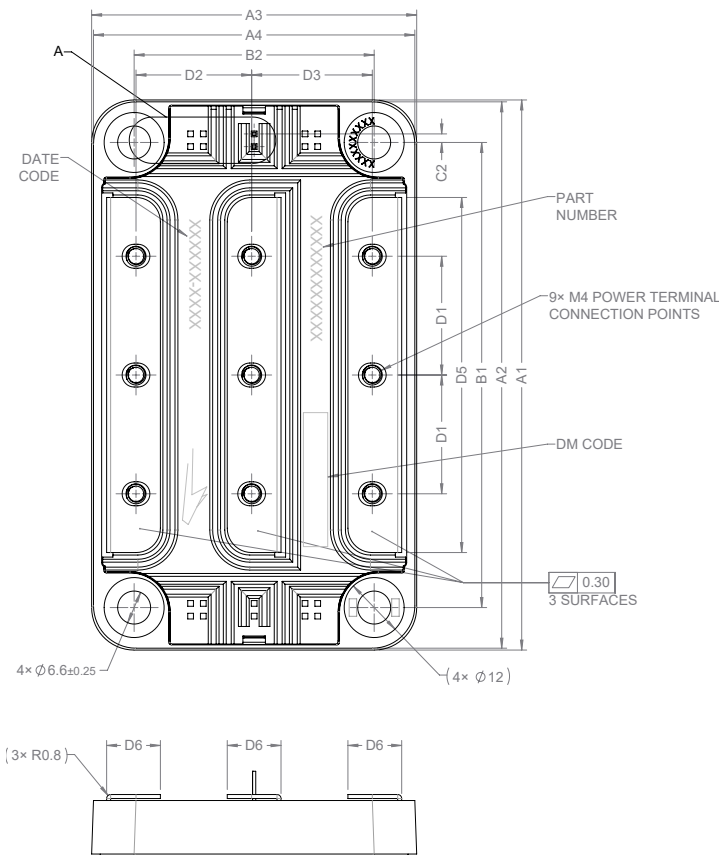

NOTE:
ALL MARKINGS SHALL
CONFORM TO PRC-00786.

DIMENSION TABLE		
SYMBOL	DIMENSION	TOLERANCE
A1	110.00	±0.60
A2	109.25	±0.60
A3	65.00	±0.60
A4	64.25	±0.60
A5	3.25	±0.30
A6	11.45	±0.60
B1	93.00	±0.30
B2	48.00	±0.30
C1	24.00	±0.40
C2	1.71	±0.40
C3	17.30	±0.50
C4	2.54	±0.30
C5	0.64	±0.30
D1	23.75	±0.50
D2	23.13	±0.50
D3	24.13	±0.50
D4	12.20	±0.50
D5	71.00	±0.30
D6	10.75	±0.30

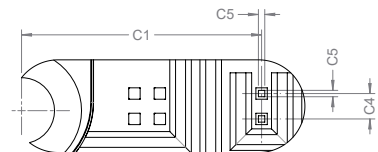

DETAIL A
SCALE: 4:1



Supporting Links & Tools

Evaluation Tools & Support

- [SpeedFit 2.0 Design Simulator™](#)
- [Technical Support Forum](#)

Application Notes

- [CPWR-AN35: 62mm Thermal Interface Material Application Note](#)
- [CPWR-AN39: KIT-CRD-CIL12N-HM User Guide](#)



Notes & Disclaimers

WOLFSPEED PROVIDES TECHNICAL AND RELIABILITY DATA, DESIGN RESOURCES, APPLICATION OR OTHER DESIGN ADVICE, WEB TOOLS, AND OTHER RESOURCES “AS IS” AND WITH ALL FAULTS, AND DISCLAIMS ALL WARRANTIES, EXPRESS AND IMPLIED, WITH RESPECT THERETO, INCLUDING WITHOUT LIMITATION ANY IMPLIED WARRANTIES OF MERCHANTABILITY, SUITABILITY, FITNESS FOR A PARTICULAR PURPOSE, OR NON-INFRINGEMENT OF THIRD-PARTY INTELLECTUAL PROPERTY RIGHTS.

This document and the information contained herein are subject to change without notice. Any such change shall be evidenced by the publication of an updated version of this document by Wolfspeed. No communication from any employee or agent of Wolfspeed or any third party shall effect an amendment or modification of this document. No responsibility is assumed by Wolfspeed for any infringement of patents or other rights of third parties which may result from use of the information contained herein. No license is granted by implication or otherwise under any patent or patent rights of Wolfspeed.

The information contained in this document (excluding examples, as well as figures or values that are labeled as “typical”) constitutes Wolfspeed’s sole published specifications for the subject product. “Typical” parameters are the average values expected by Wolfspeed in large quantities and are provided for informational purposes only. Any examples provided herein have not been produced under conditions intended to replicate any specific end use. Product performance can and does vary due to a number of factors.

This product has not been designed or tested for use in, and is not intended for use in, any application in which failure of the product would reasonably be expected to cause death, personal injury, or property damage. For purposes of (but without limiting) the foregoing, this product is not designed, intended, or authorized for use as a critical component in equipment implanted into the human body, life-support machines, cardiac defibrillators, and similar emergency medical equipment; air traffic control systems; or equipment used in the planning, construction, maintenance, or operation of nuclear facilities. Notwithstanding any application-specific information, guidance, assistance, or support that Wolfspeed may provide, the buyer of this product is solely responsible for determining the suitability of this product for the buyer’s purposes, including without limitation (1) selecting the appropriate Wolfspeed products for the buyer’s application, (2) designing, validating, and testing the buyer’s application, and (3) ensuring the buyer’s application meets applicable standards and any other legal, regulatory, and safety-related requirements.

RoHS Compliance

The levels of RoHS restricted materials in this product are below the maximum concentration values (also referred to as the threshold limits) permitted for such substances, or are used in an exempted application, in accordance with EU Directive 2011/65/EC (RoHS2), as implemented January 2, 2013. RoHS Declarations for this product can be obtained from your Wolfspeed representative or from the Product Documentation sections of www.wolfspeed.com.

REACH Compliance

REACH substances of high concern (SVHCs) information is available for this product. Since the European Chemical Agency (ECHA) has published notice of their intent to frequently revise the SVHC listing for the foreseeable future, please contact your Wolfspeed representative to ensure you get the most up-to-date REACH SVHC Declaration. REACH banned substance information (REACH Article 67) is also available upon request.

Contact info:

4600 Silicon Drive
Durham, NC 27703 USA
Tel: +1.919.313.5300
www.wolfspeed.com/power