

CAS100H12AM1

1.2 kV, 100A Silicon Carbide Half-Bridge Module

Z-FET™ MOSFET and Z-Rec™ Diode

V_{DS}	1.2 kV
$R_{DS(on)}$ ($T_J = 25^\circ\text{C}$)	16 mΩ
E_{OFF} ($T_J = 125^\circ\text{C}$)	1.8 mJ

Features

- Ultra Low Loss
- Zero Turn-off Tail Current from MOSFET
- Zero Reverse Recovery Current from Diode
- High-Frequency Operation
- Positive Temperature Coefficient on V_F and $V_{DS(on)}$
- AISiC Baseplate, AMB Si_3N_4 Substrate

System Benefits

- Enables Compact and Lightweight Systems
- High Efficiency Operation
- Ease of Transistor Gate Control
- Reduced Cooling Requirements
- Reduced System Cost

Applications

- High Power Converters
- Motor Drives
- Solar Inverters
- UPS and SMPS
- Induction Heating

Package



Part Number	Package	Marking
CAS100H12AM1	Half-Bridge Module	CAS100H12AM1

Maximum Ratings ($T_C = 25^\circ\text{C}$ unless otherwise specified)

Symbol	Parameter	Value	Unit	Test Conditions	Notes
V_{DS}	Drain - Source Voltage	1.2	kV		
V_{GS}	Gate - Source Voltage	-5/+20	V		
I_D	Continuous Drain Current	168	A	$V_{GS} = 20\text{V}, T_C = 25^\circ\text{C}$	Fig. 25
		117		$V_{GS} = 20\text{V}, T_C = 90^\circ\text{C}$	
$I_{D(pulse)}$	Pulsed Drain Current	400	A	Pulse width Limited by $T_{jmax}, T_C = 25^\circ\text{C}$	
T_J	Junction Temperature	150	$^\circ\text{C}$		
T_C, T_{STG}	Case and Storage Temperature Range	-55 to +125	$^\circ\text{C}$		
V_{isol}	Case Isolation Voltage	6	kV	AC, $t=1\text{min}$	
L_{Stray}	Stray Inductance	20	nH	Measured from D1 to S2	
M	Mounting Torque	2.94	Nm		
G	Weight	150	g	Measured without fasteners	
	Clearance Distance	12.2	mm	Terminal to terminal	
	Creepage Distance	17.3	mm	Terminal to terminal	
		20.2	mm	Terminal to base plate	
Pd	Power Dissipation	568	W		Fig 24



Electrical Characteristics ($T_c = 25^\circ\text{C}$ unless otherwise specified)

Symbol	Parameter	Min.	Typ.	Max.	Unit	Test Conditions	Note
$V_{(BR)DSS}$	Drain - Source Breakdown Voltage	1.2			kV	$V_{GS} = 0V, I_D = 100\mu A$	
$V_{GS(th)}$	Gate Threshold Voltage	2.0	2.5		V	$V_{DS} = V_{GS}, I_D = 5mA$	Fig. 9
		2.6	3.1			$V_{DS} = V_{GS}, I_D = 50mA$	
			1.8			$V_{DS} = V_{GS}, I_D = 5mA, T_J = 150^\circ\text{C}$	
			2.4			$V_{DS} = V_{GS}, I_D = 50mA, T_J = 150^\circ\text{C}$	
I_{DSS}	Zero Gate Voltage Drain Current		5	500	μA	$V_{DS} = 1200V, V_{GS} = 0V$	
			50	1250		$V_{DS} = 1200V, V_{GS} = 0V, T_J = 150^\circ\text{C}$	
I_{GSS}	Gate-Source Leakage Current			0.25	μA	$V_{GS} = 20V, V_{DS} = 0V$	
$R_{DS(on)}$	On State Resistance		16	20	m Ω	$V_{GS} = 20V, I_D = 100A$	Fig. 7
			20	24		$V_{GS} = 20V, I_D = 100A, T_J = 150^\circ\text{C}$	
g_{fs}	Transconductance		31		S	$V_{DS} = 20V, I_D = 100A$	Fig. 8
			32			$V_{DS} = 20V, I_D = 100A, T_J = 150^\circ\text{C}$	
C_{iss}	Input Capacitance		10.7		nF	$V_{DS} = 600V, V_{GS} = 0V$ $f = 1MHz, V_{AC} = 25mV$	Fig. 16,17
C_{oss}	Output Capacitance		0.970				
C_{rss}	Reverse Transfer Capacitance		0.037				
E_{ON}	Turn-On Switching Energy	(25 $^\circ\text{C}$) (125 $^\circ\text{C}$)	4.6 3.9		mJ	$V_{DD} = 800V, V_{GS} = +20V/-5V$ $I_D = 100A, R_G = 5.1\Omega$ Inductive Load = 200 μH Note: IEC 60747-8-4 Definitions	Fig. 21
E_{off}	Turn-Off Switching Energy	(25 $^\circ\text{C}$) (125 $^\circ\text{C}$)	1.7 1.8				
R_G	Internal Gate Resistance		1.25		Ω	$f = 1MHz, V_{AC} = 25mV$	
Q_G	Gate Charge		490		nC	$V_{DD} = 600V, I_D = 100A$	Fig. 18
Resistive Switching							
$t_{d(on)}$	Turn-on delay time		58		ns	$V_{DD} = 800V, R_{LOAD} = 8\Omega$ $V_{GS} = +20/-5V, R_G = 5.1\Omega$ Note: IEC 60747-8-4 Definitions	Fig. 19, 20
$t_{r(on)}$	$V_{S1/D2}$ fall time 90% to 10%		76		ns		
$t_{d(off)}$	Turn-off delay time		82		ns		
$t_{f(off)}$	$V_{S1/D2}$ rise time 10% to 90%		46		ns		



Free-Wheeling SiC Schottky Diode Characteristics

Symbol	Parameter	Min.	Typ.	Max.	Unit	Test Conditions	Note
V _{SD}	Diode Forward Voltage		1.8	2.2	V	I _F = 100A, V _{GS} = 0	Fig. 11
			2.5			I _F = 100A, T _J = 150°C	Fig. 12
Q _C	Total Capacitive Charge		1.6		μC	I _F = 100A, V _R = 600V di _F /dt = 2200A/μs, T _J = 25°C	
t _{RR}	Reverse Recovery Time		47		ns		
E _{RR}	Reverse Recovery Energy		0.5		mJ		

Thermal Characteristics

Symbol	Parameter	Min.	Typ.	Max.	Unit	Test Conditions	Note
R _{thJCM}	Thermal Resistance Junction-to-Case for MOSFET		0.22	0.24	°C/W		
R _{thJCD}	Thermal Resistance Junction-to-Case for Diode		0.35	0.37			

Module Application Note: The SiC MOSFET module switches at speeds beyond what is customarily associated with IGBT based modules. Therefore, special precautions are required to realize the best performance. The interconnection between the gate driver and module housing needs to be as short as possible. This will afford the best switching time and avoid the potential for device oscillation. Also, great care is required to insure minimum inductance between the module and link capacitors to avoid excessive V_{DS} overshoots.

Please Refer to application note: [CPWR-AN12] Design Considerations when using Cree SiC Modules.

Typical Performance

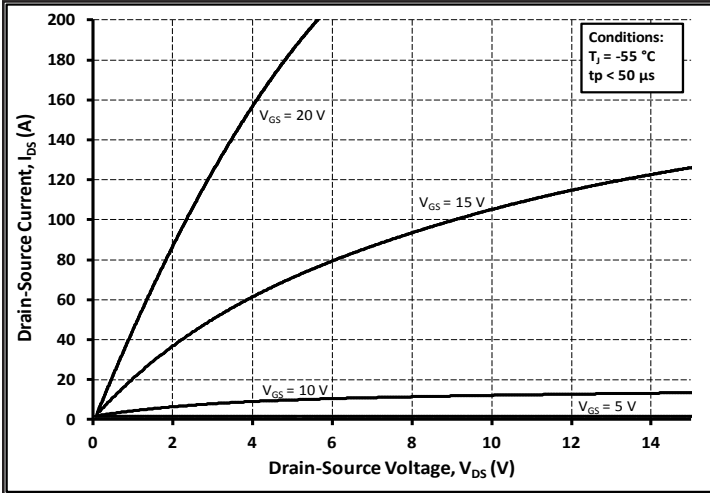

Figure 1. Typical Output Characteristics $T_j = -55^\circ\text{C}$

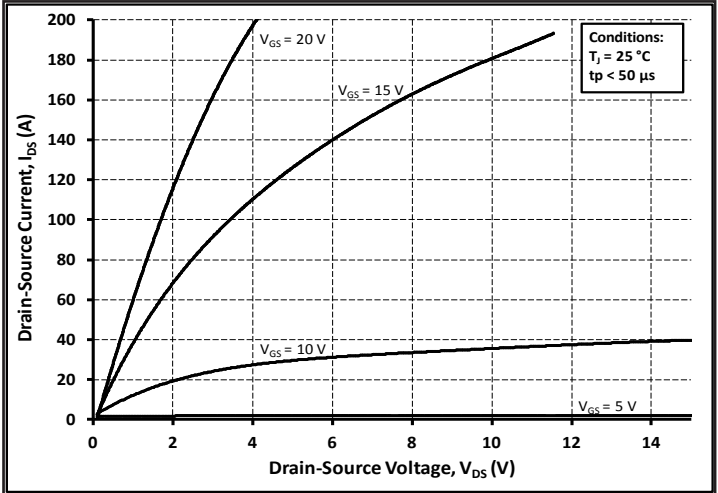

Figure 2. Typical Output Characteristics $T_j = 25^\circ\text{C}$

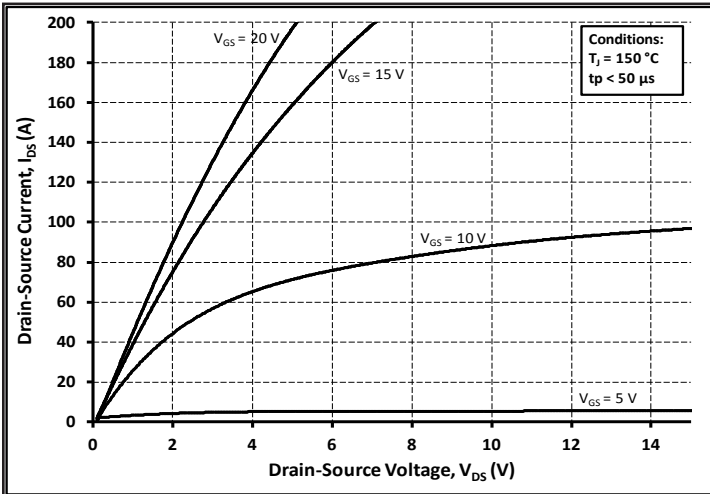

Figure 3. Typical Output Characteristics $T_j = 150^\circ\text{C}$

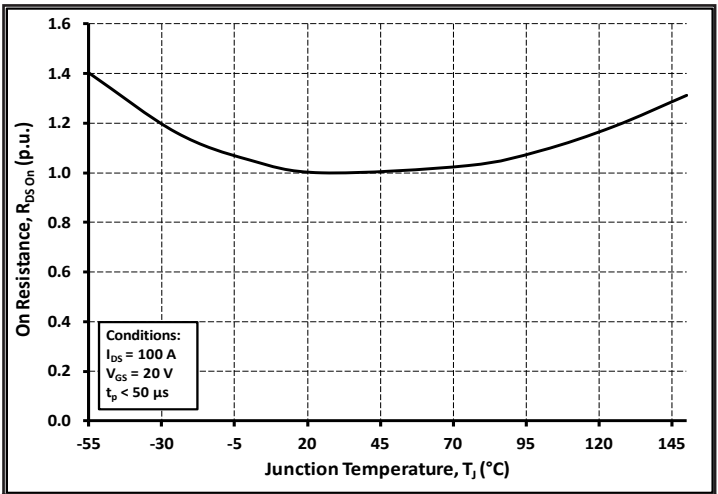

Figure 4. Normalized On-Resistance vs. Temperature

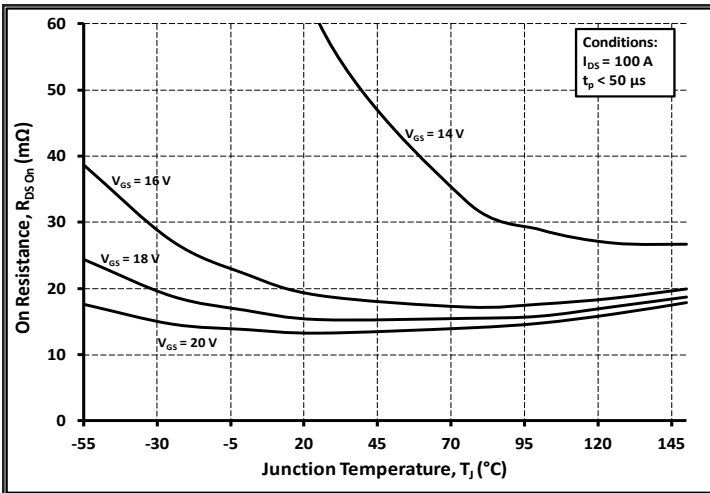

Figure 5. On-Resistance vs. Temperature for Various Gate-Source Voltages

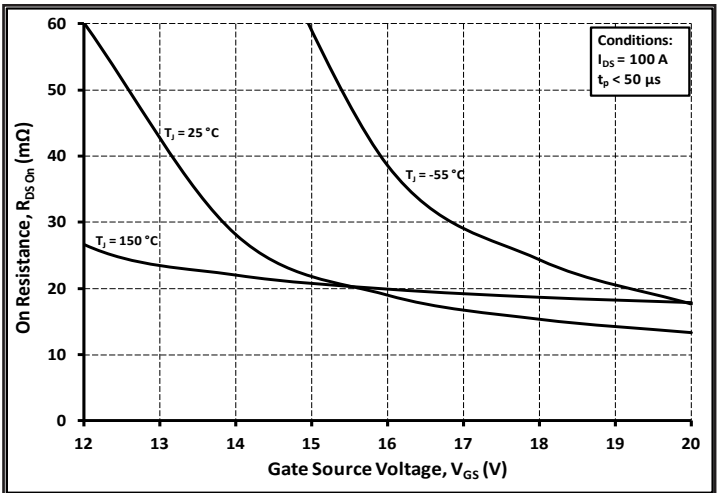

Figure 6. On-Resistance vs. Gate Source Voltage for Various Temperature

Typical Performance

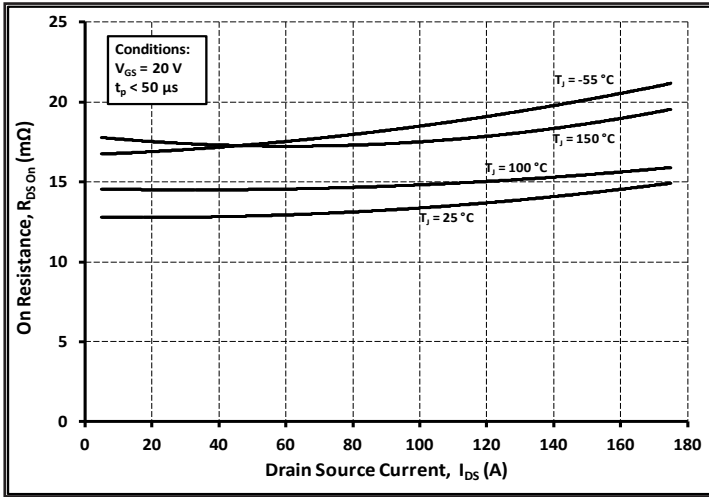

Figure 7. On-Resistance vs. Drain Current for Various Temperatures

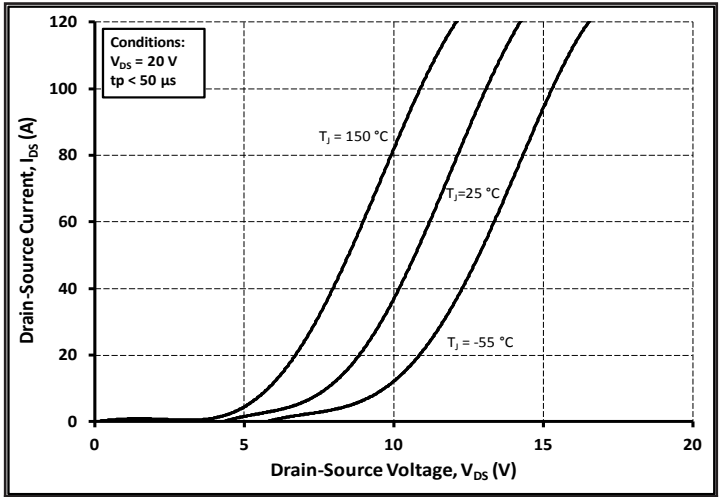

Figure 8. Transfer Characteristics for Various Junction Temperatures

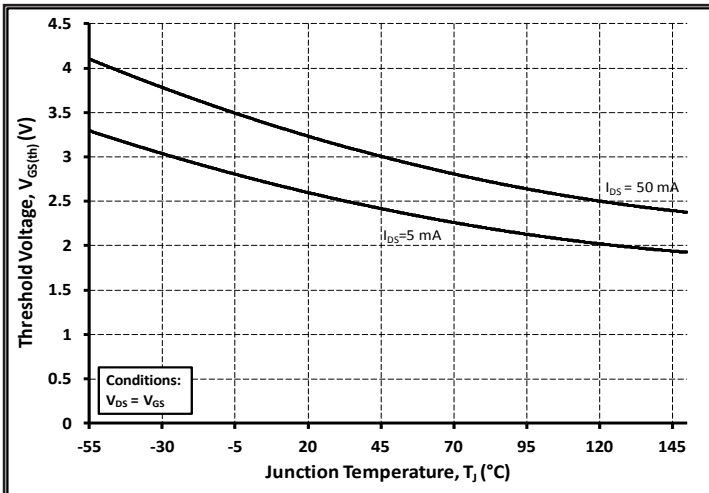

Figure 9. Threshold Voltage vs. Junction Temperature

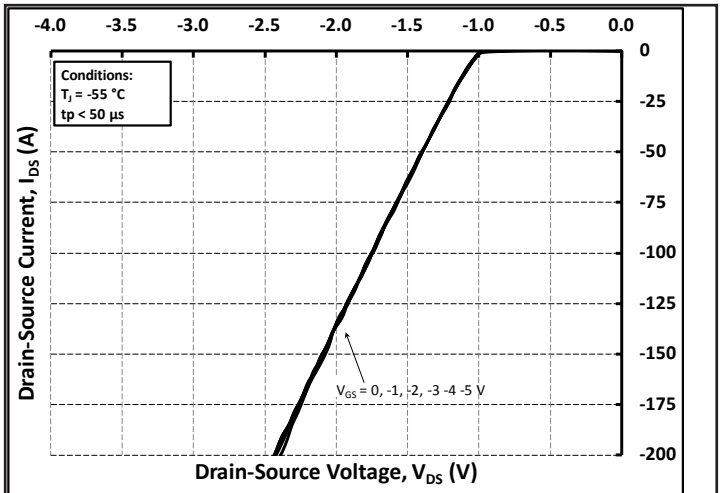

Figure 10. Typical Diode Characteristics $T_J = -55^\circ\text{C}$

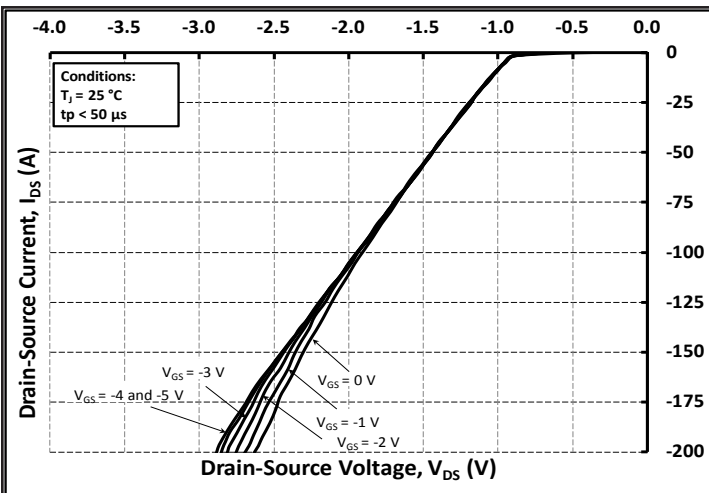

Figure 11. Typical Diode Characteristics $T_J = 25^\circ\text{C}$

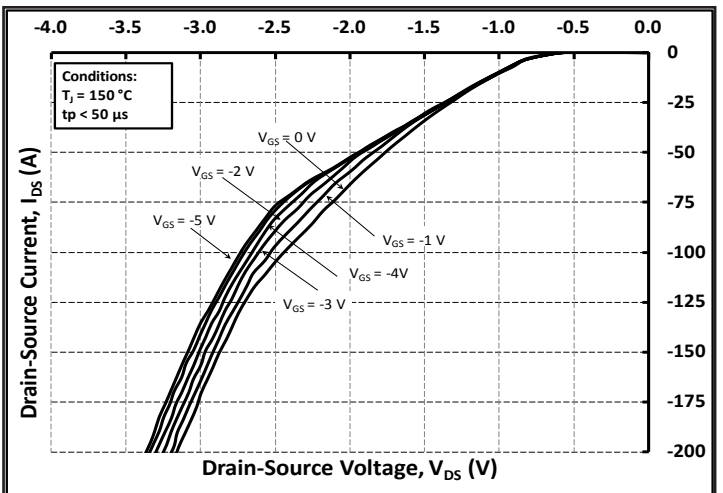

Figure 12. Typical Diode Characteristics $T_J = 150^\circ\text{C}$

Typical Performance

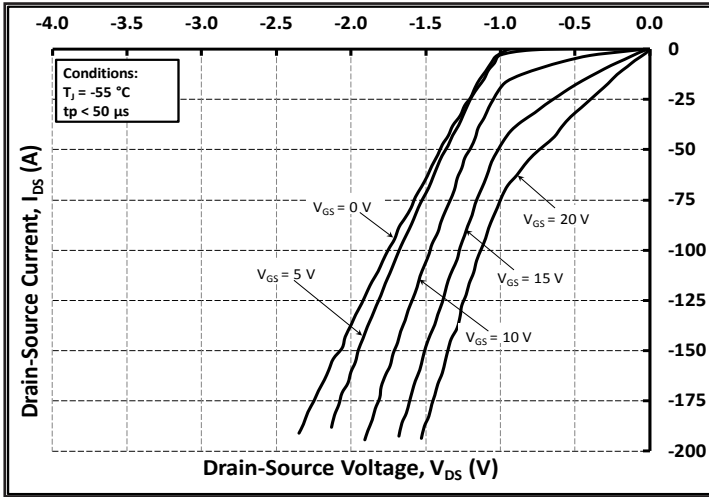

Figure 13. Typical 3rd Quadrant Characteristics
 $T_j = -55\text{ }^\circ\text{C}$

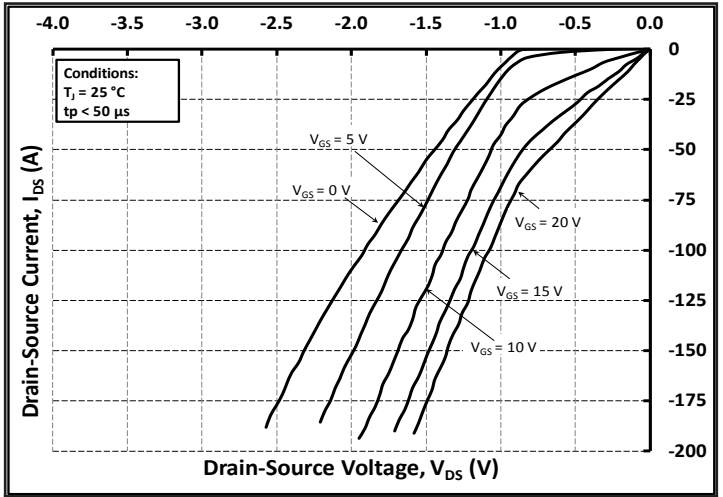

Figure 14. Typical 3rd Quadrant Characteristics
 $T_j = 25\text{ }^\circ\text{C}$

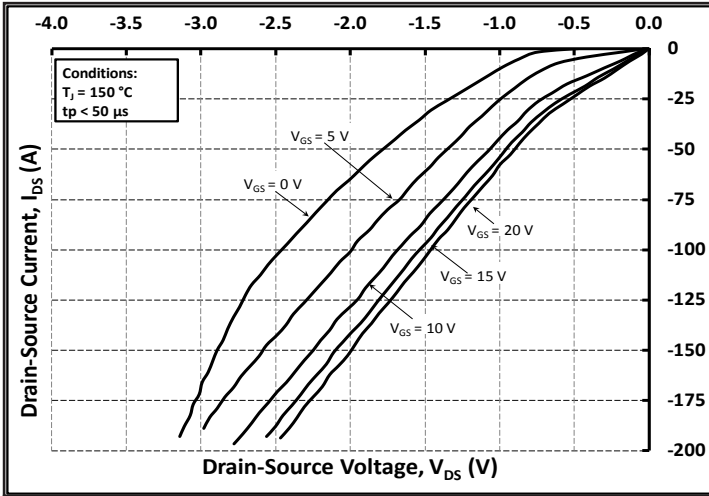

Figure 15. Typical 3rd Quadrant Characteristics
 $T_j = 150\text{ }^\circ\text{C}$

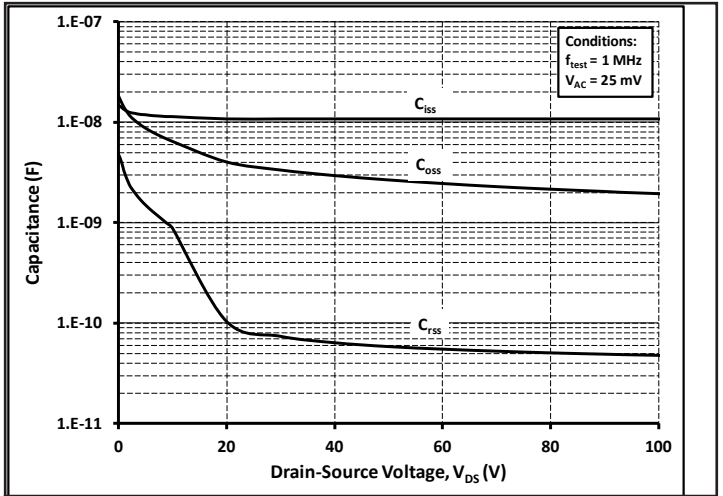

Figure 16. Typical Capacitances vs. Drain-Source Voltage (0 - 100V)

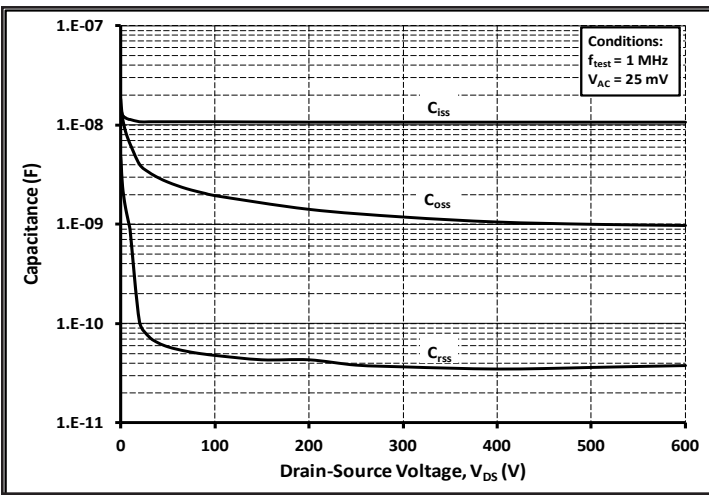

Figure 17. Typical Capacitances vs. Drain-Source Voltage (0 - 600V)

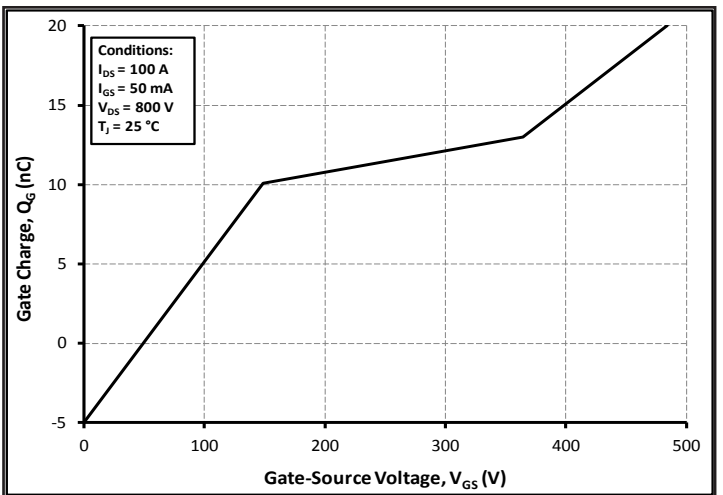

Figure 18. Typical Gate Charge Characteristic

Typical Performance

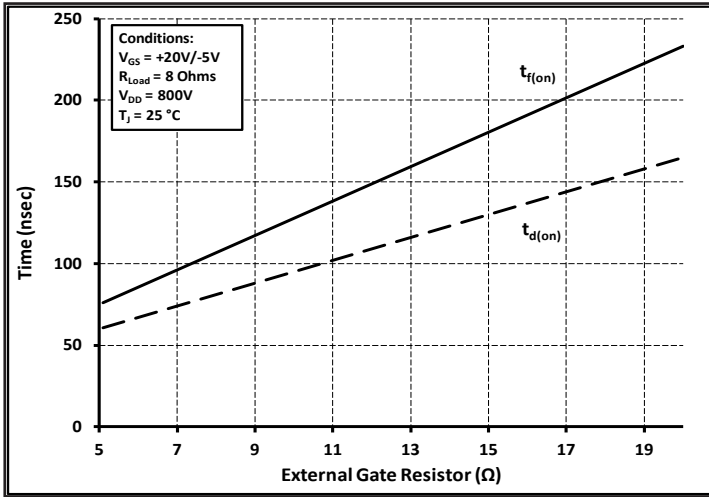

Figure 19. Resistive Switching Times vs. R_G (Turn on)

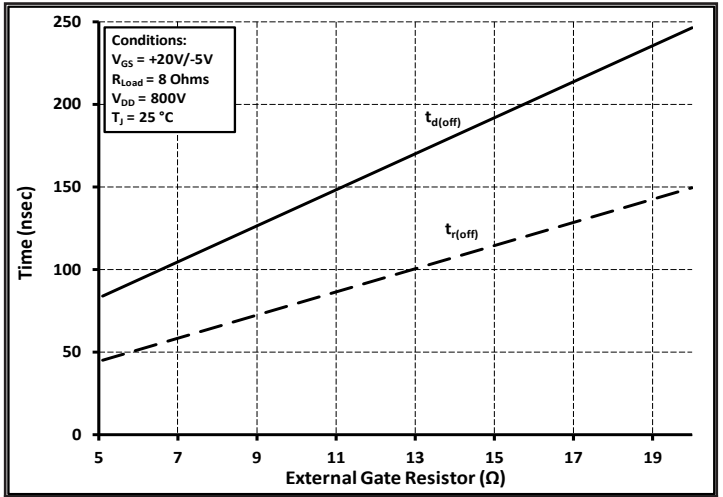

Figure 20. Resistive Switching Times vs. R_G (Turn off)

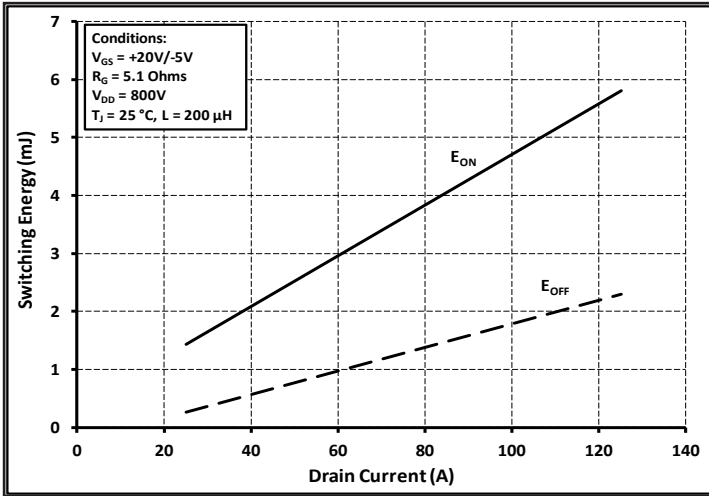

Figure 21. Clamped Inductive Switching Energy vs. Drain Current

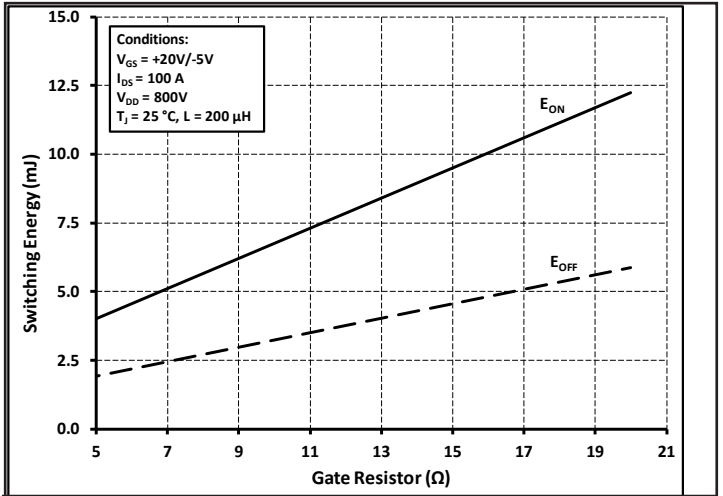

Figure 22. Clamped Inductive Switching Energy vs. Gate Resistance

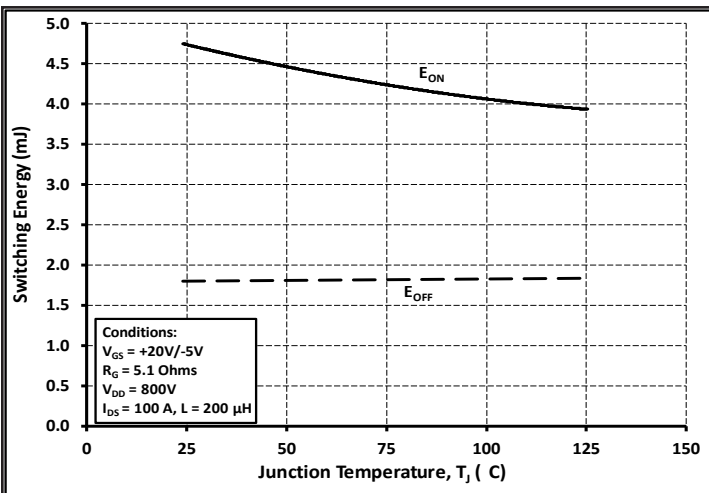

Figure 23. Clamped Inductive Switching Energy vs. Temperature

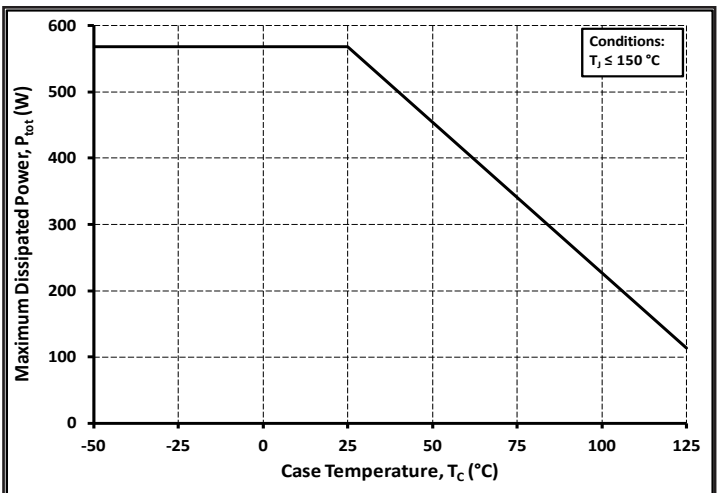

Figure 24. Power Dissipation Derating Curve

Typical Performance

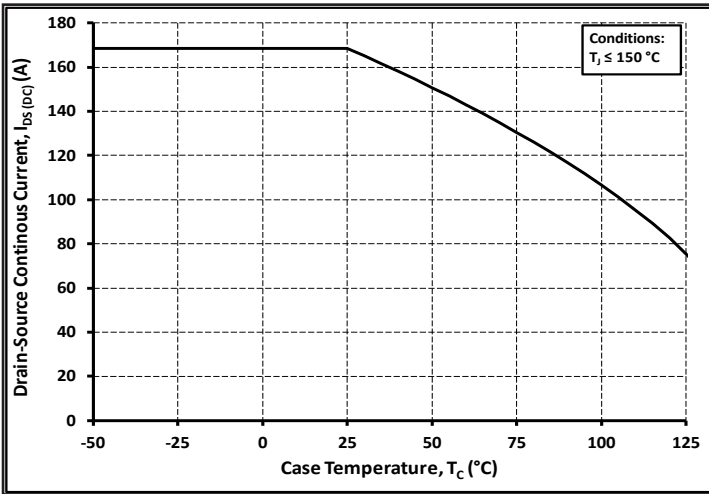

Figure 25. Continuous Current Derating Curve

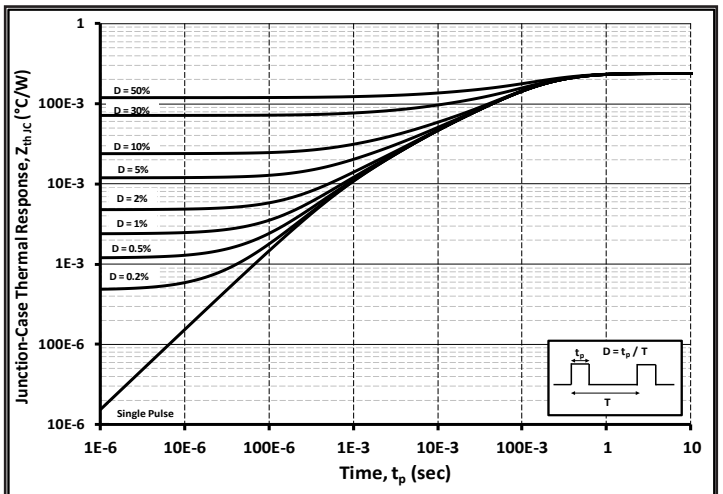

Figure 26. Transient Thermal Impedance - MOSFET

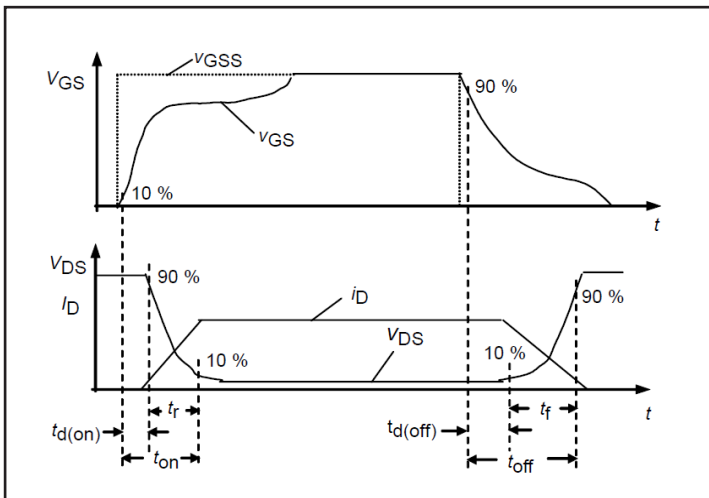
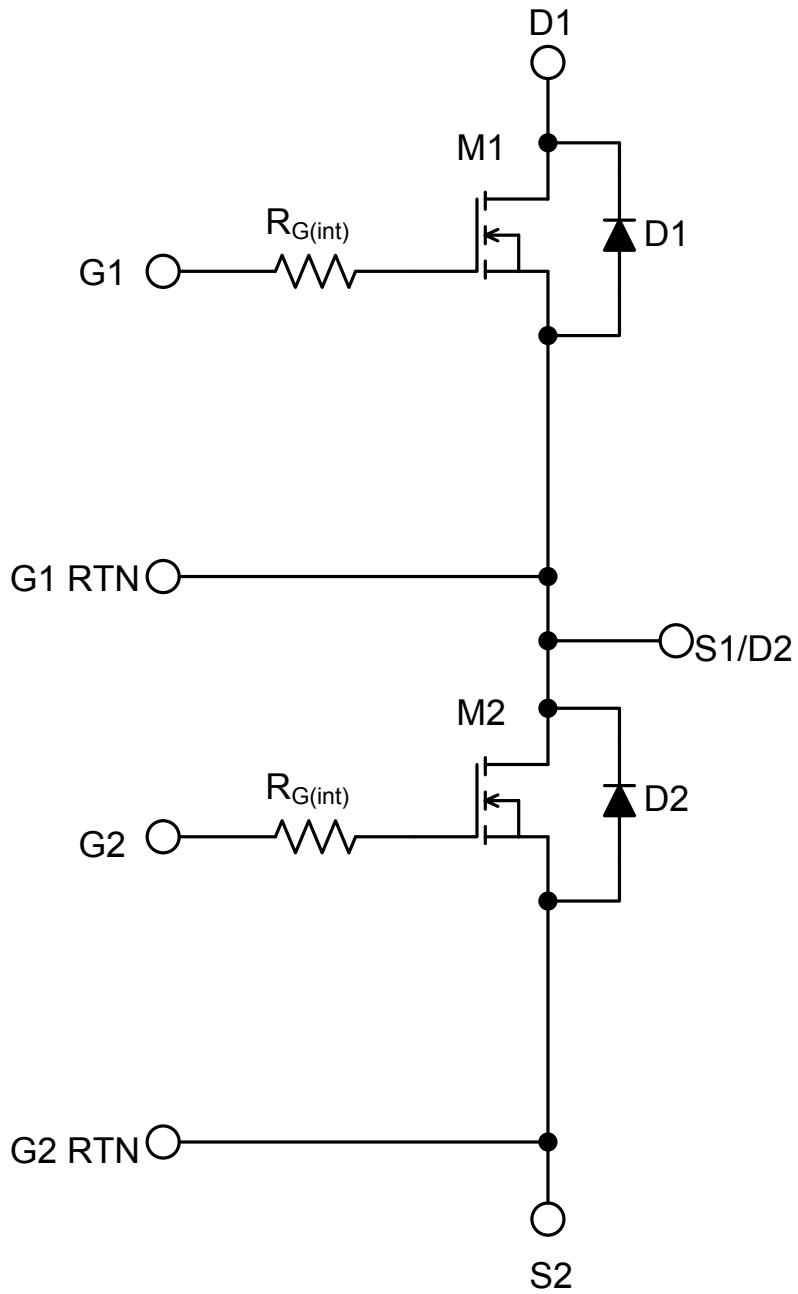
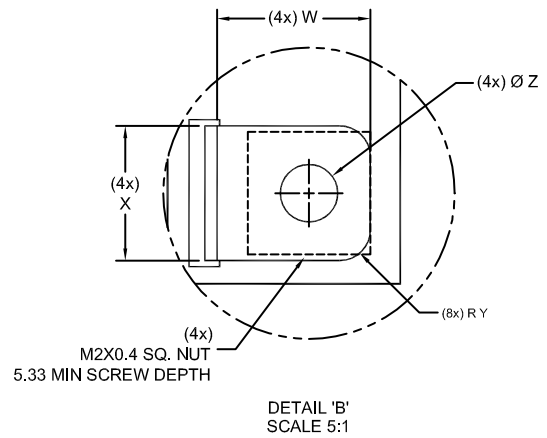
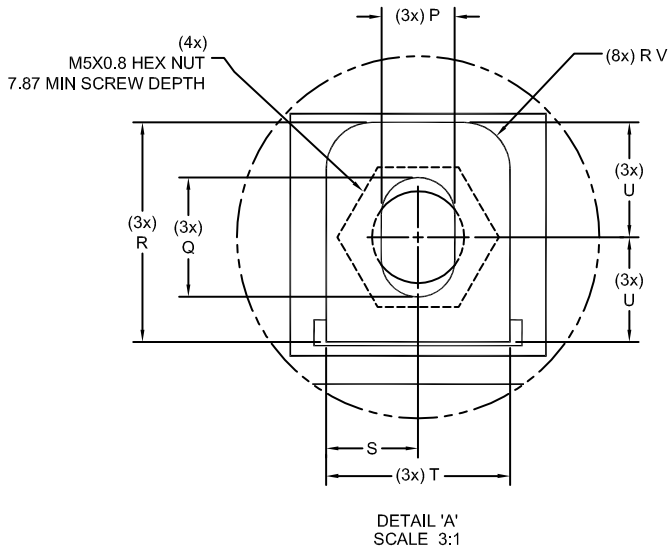
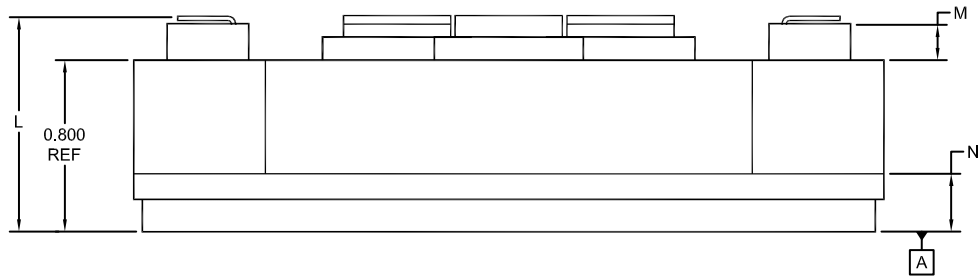
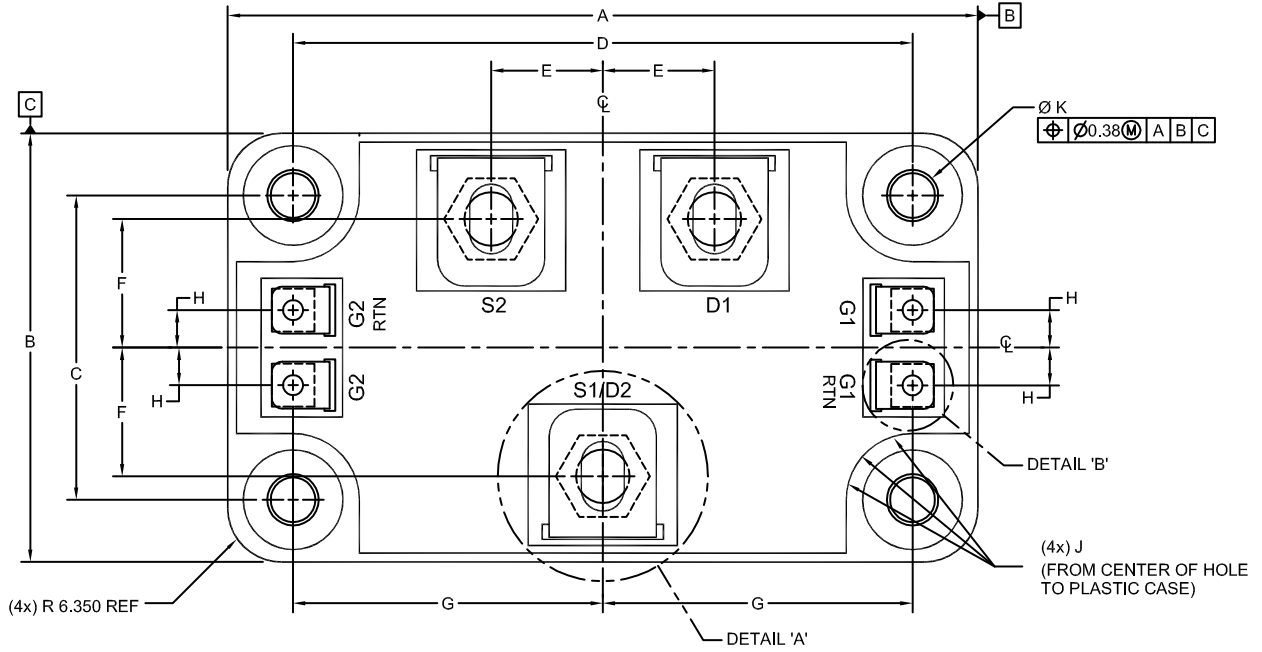

Figure 27. Resistive Switching Time Description

Circuit Diagram



Package Dimensions (mm)



Package Dimensions (mm)

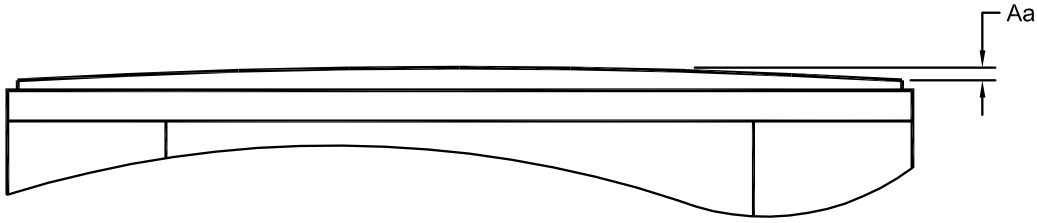

POWER MODULE (SIDE VIEW)
(EXAGGERATED DOME)
(NOT TO SCALE)

Package Dimensions (mm)

REF	MIN	MAX
A	88.14	89.15
B	50.04	51.05
C	35.81	36.32
D	73.15	73.66
E	12.60	13.87
F	14.61	15.88
G	36.07	37.34
H	3.810	5.080
J	6.096	—————
K	5.283	5.715
L	25.02	25.78
M	2.286	—————
N	6.477	7.239
P	4.953	5.842
Q	7.874	8.636
R	12.70	17.78
S	5.080	7.620
T	12.70	13.97
U	—————	10.16
V	2.540	—————
W	—————	6.350
X	—————	5.588
Y	1.270	—————
Z	2.286	2.794
Aa	0.000	0.178

This product has not been designed or tested for use in, and is not intended for use in, applications implanted into the human body nor in applications in which failure of the product could lead to death, personal injury or property damage, including but not limited to equipment used in the operation of nuclear facilities, life-support machines, cardiac defibrillators or similar emergency medical equipment, aircraft navigation or communication or control systems, air traffic control systems, or weapons systems.

Copyright © 2014 Cree, Inc. All rights reserved. The information in this document is subject to change without notice. Cree and the Cree logo are registered trademarks and Z-Rec is a trademark of Cree, Inc.

Cree, Inc.
4600 Silicon Drive
Durham, NC 27703
USA Tel: +1.919.313.5300
Fax: +1.919.313.5451
www.cree.com/power